



Hinges / Continuous hinge

Rolled knuckle continuous hinge 15mm open

Opening angle 270°. Other lengths and pin materials are available on request. Specific drilling requirements are also available on request.

A	B	C	D	E	note	material	finish	part number	pin material	weight
2040	15	0.7	1.6	15	undrilled	steel	raw	40-1-3327	steel	260g



Rolled knuckle continuous hinge 20mm open

Opening angle 270°. Other lengths and pin materials are available on request. Specific drilling requirements are also available on request.

A	B	C	D	E	F	G	S	note	material	finish	part number	pin material	weight
2040	20	0.8	2	15	11.2	60	2.8	drilled	steel	raw	40-1-3321	steel	310g
2040	20	0.8	2	15				undrilled	steel	raw	40-1-3328	steel	320g
2000	20	0.6	2.4	15				undrilled	5754 alu	raw	41-1-3529	steel	117g
2040	20	0.8	2	15				undrilled	304 stainless steel	raw	42-1-3664	stainless steel	320g
2040	20	0.8	2	15	11.2	60	2.8	drilled	304 stainless steel	raw	42-1-4195	stainless steel	310g
2040	20	0.7	1.8	15	11.2	60	2.8	drilled	brass	polished	43-1-3300	stainless steel	340g
2040	20	0.7	1.8	15				undrilled	brass	raw	43-1-3310	stainless steel	340g

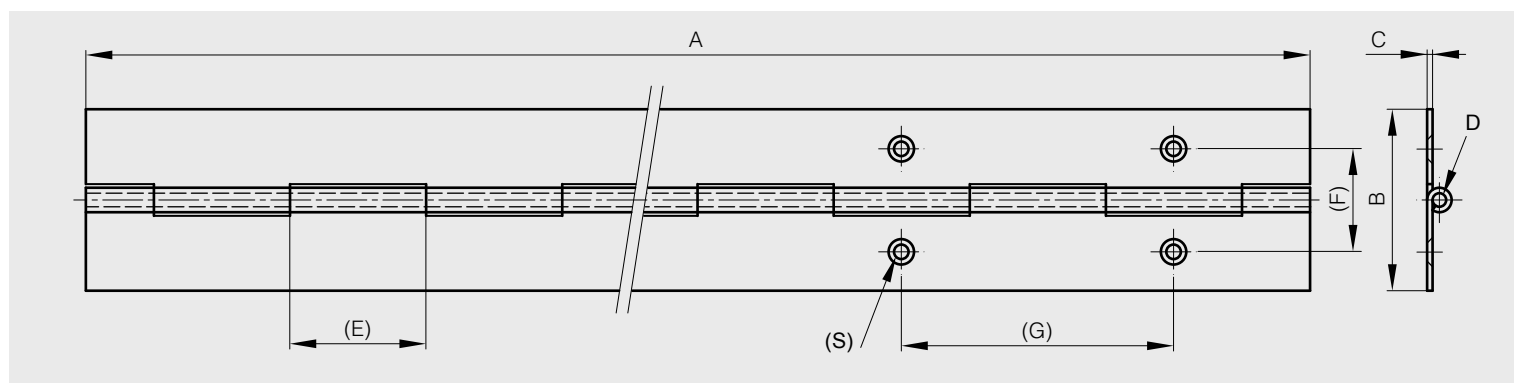



Hinges / Continuous hinge

Rolled knuckle continuous hinge 25mm open

Opening angle 270°. Other lengths and pin materials are available on request.

Specific drilling requirements are also available on request.

Hinge in raw galvanised steel is made of pregalvanised steel. Therefore any cut surface is ungalvanised.



A	B	C	D	E	F	G	S	note	material	finish	part number	pin material	weight
2040	25	0.8	2	15	14.2	60	2.8	drilled	steel	raw	40-1-3322	steel	420g
2040	25	0.8	2	15				undrilled	steel	raw	40-1-3329	steel	440g
1800	25	1.2	3	30				undrilled	galvanised steel	raw	40-1-4677	brass	500g
2000	25	0.8	2	15				undrilled	5754 alu	raw	41-1-3530	steel	146g
2040	25	0.8	2	15	14.2	60	3.6	drilled	304 stainless steel	raw	42-1-4196	stainless steel	420g
2040	25	0.8	2	15				undrilled	304 stainless steel	raw	42-1-3767	stainless steel	448g
1800	25	1	2	15				undrilled	304 stainless steel	raw	42-1-4096	stainless steel	500g
2040	25	1	2	15				undrilled	304 stainless steel	raw	42-1-3949	stainless steel	558g
2040	25	0.8	2	15	14.2	60	3.6	drilled	brass	polished	43-1-3301	stainless steel	460g
2040	25	0.8	2	15				undrilled	brass	raw	43-1-3311	stainless steel	470g

Rolled knuckle continuous hinge 30mm open

Opening angle 270°. Other lengths and pin materials are available on request.

Specific drilling requirements are also available on request.

A	B	C	D	E	F	G	S	note	material	finish	part number	pin material	weight
2040	30	0.8	2	15	16.8	60	3.9	drilled	steel	raw	40-1-3323	steel	460g
2040	30	0.8	2	15				undrilled	steel	raw	40-1-3330	steel	510g
2040	30	1	2	15				undrilled	steel	raw	40-1-3679	steel	640g
2040	30	1	2	15	16.8	60	3.9	drilled	steel	raw	40-1-3680	steel	640g
2000	30	2	6	30				undrilled	steel	raw	40-1-4370	steel	1800g
2040	30	0.8	2	15				undrilled	304 stainless steel	raw	42-1-3580	stainless steel	510g
1800	30	1	2	15				undrilled	304 stainless steel	raw	42-1-4089	stainless steel	500g
2040	30	1	2	15				undrilled	304 stainless steel	raw	42-1-3300	stainless steel	670g
2040	30	1	2	15	16.8	60	3.9	drilled	304 stainless steel	raw	42-1-4197	stainless steel	640g
2000	30	1.5	4	30				undrilled	304 stainless steel	raw	42-1-3950	stainless steel	1283g
2000	30	2	6	25				undrilled	304 stainless steel	raw	42-1-3948	stainless steel	1800g
2040	30	1	2	15				undrilled	316 stainless steel	raw	42-1-4000	stainless steel	670g
2040	30	0.8	2	15				undrilled	brass	polished	43-1-3302	stainless steel	530g
2040	30	0.8	2	15				undrilled	brass	raw	43-1-3312	stainless steel	520g
2040	30	1	2	15				undrilled	brass	raw	43-1-3523	stainless steel	700g
2040	30	1	2	15				undrilled	brass	polished	43-1-3524	stainless steel	710g

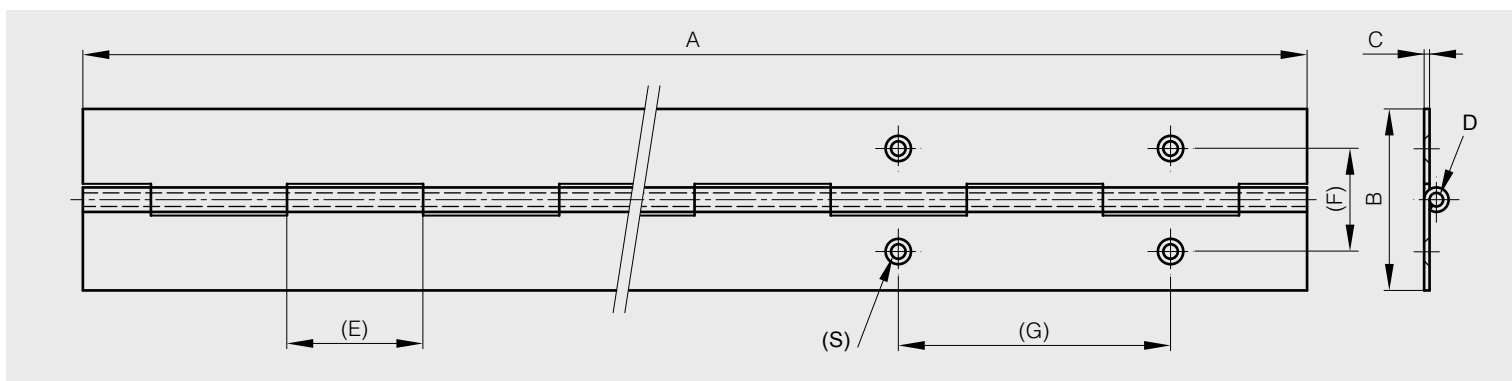



Hinges / Continuous hinge

Rolled knuckle continuous hinge 32mm open

new!

Opening angle 270°. Other lengths and pin materials are available on request.
Specific drilling requirements are also available on request.

A	B	C	D	E	note	material	finish	part number	pin material	weight
1800	32	1.2	3	30	undrilled	304 stainless steel	raw	42-1-4346	stainless steel	790g



Rolled knuckle continuous hinge 35mm open

Opening angle 270°. Other lengths and pin materials are available on request.
Specific drilling requirements are also available on request.

A	B	C	D	E	F	G	S	note	material	finish	part number	pin material	weight
2040	35	1	2	15	19.5	60	4.5	drilled	steel	raw	40-1-3324	steel	680g
2040	35	1	2	15				undrilled	steel	raw	40-1-3332	steel	700g
2000	35	1	3	30				undrilled	5754 alu	raw	41-1-3532	alu	232g

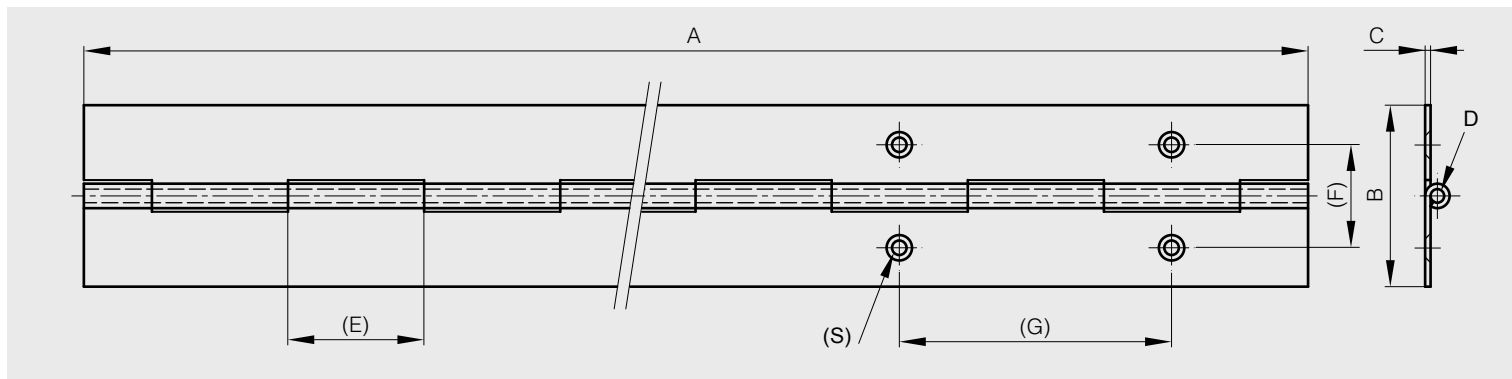



Hinges / Continuous hinge

Rolled knuckle continuous hinge 40mm open

Opening angle 270°. Other lengths and pin materials are available on request.
 Specific drilling requirements are also available on request.
 Hinge in raw galvanised steel is made of pregalvanised steel. Therefore any cut surface is ungalvanised.



A	B	C	D	E	F	G	S	note	material	finish	part number	pin material	weight
2040	40	0.8	2	15				undrilled	steel	raw	40-1-3703	steel	650g
2040	40	1.2	3	30				undrilled	steel	raw	40-1-3681	steel	1000g
2040	40	1.2	3	30	22.7	60	3.2	drilled	steel	raw	40-1-3682	steel	1000g
2040	40	1.5	4	15				undrilled	steel	raw	40-1-3683	steel	1400g
1800	40	1.2	3	30				undrilled	galvanised steel	raw	40-1-4691	brass	1520g
2000	40	1.2	3	20				undrilled	5754 alu	raw	41-1-3520	alu	356g
2040	40	1.5	4	15				undrilled	5754 alu	raw	41-1-3521	alu	500g
1800	40	1.2	3	30				undrilled	304 stainless steel	raw	42-1-4347	stainless steel	940g
2040	40	1.2	3	30	22.7	60	4.2	drilled	304 stainless steel	raw	42-1-4349	stainless steel	1000g
2040	40	1.2	3	30				undrilled	304 stainless steel	raw	42-1-4350	stainless steel	1000g
2040	40	1.5	4	15				undrilled	304 stainless steel	raw	42-1-3301	stainless steel	1400g
2040	40	1.5	4	15	22.7	60	4	drilled	304 stainless steel	raw	42-1-4199	stainless steel	1400g
2040	44	2	6	30				undrilled	304 stainless steel	raw	42-1-3770	stainless steel	2463g
2040	40	1.5	4	15				undrilled	316 stainless steel	raw	42-1-4001	stainless steel	1400g
2040	40	0.8	2	15				undrilled	430 stainless steel	raw	42-1-3665	stainless steel	650g
2040	40	1.2	3	30				undrilled	brass	raw	43-1-3525	stainless steel	1080g
2040	40	1.2	3	30				undrilled	brass	polished	43-1-3526	stainless steel	1090g

Rolled knuckle continuous hinge 50mm open

Opening angle 270°. Other lengths and pin materials are available on request.
 Specific drilling requirements are also available on request.
 Hinge in raw galvanised steel is made of pregalvanised steel. Therefore any cut surface is ungalvanised.

A	B	C	D	E	F	G	S	note	material	finish	part number	pin material	weight
2040	50	1.2	3	30				undrilled	steel	raw	40-1-3704	steel	1300g
2040	50	1.2	3	30	28	60	4	drilled	steel	raw	40-1-3758	steel	1270g
2040	50	2	6	30				undrilled	steel	raw	40-1-4355	steel	2486g
1800	50	1.2	3	30				undrilled	galvanised steel	raw	40-1-4679	brass	1800g
2000	50	1.2	3	20				undrilled	5754 alu	raw	41-1-3531	alu	459g
2000	50	1.5	4	15				undrilled	5754 alu	raw	41-1-3522	alu	612g
1800	50	1.2	3	30				undrilled	304 stainless steel	raw	42-1-4348	stainless steel	1100g
2040	50	1.2	3	30	28	60	4	drilled	304 stainless steel	raw	42-1-4352	stainless steel	1270g
2040	50	1.2	3	30				undrilled	304 stainless steel	raw	42-1-4353	stainless steel	1300g
1800	50	1.5	4	15				undrilled	304 stainless steel	raw	42-1-4219	stainless steel	1500g
2000	50	2	4	25				undrilled	304 stainless steel	raw	42-1-3918	stainless steel	2350g
2040	50	1.2	3	30				undrilled	316 stainless steel	raw	42-1-4354	stainless steel	1310g
2040	50	1.2	3	30				undrilled	brass	raw	43-1-3556	stainless steel	1424g

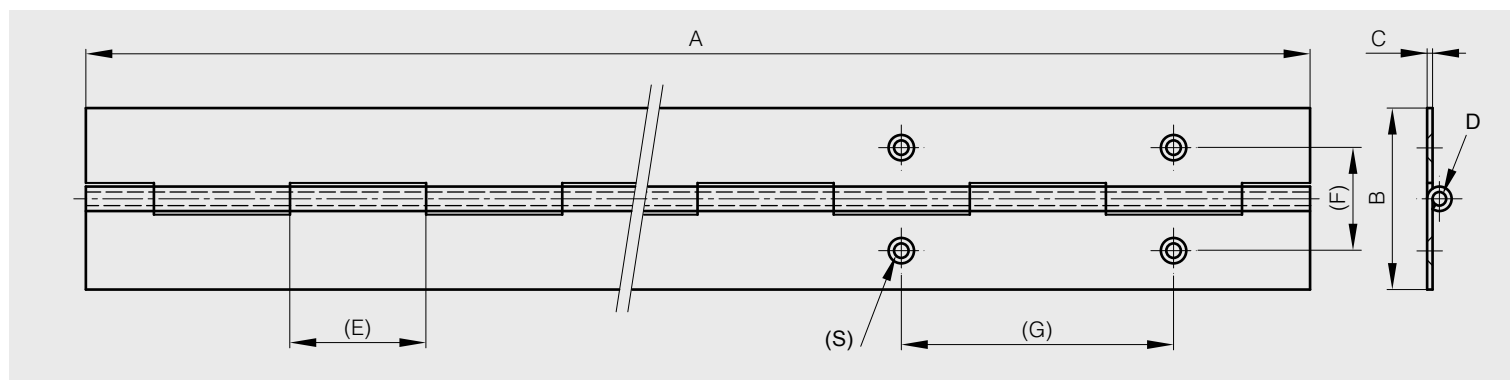



Hinges / Continuous hinge

Rolled knuckle continuous hinge 57mm open

new!

Opening angle 270°. Other lengths and pin materials are available on request.
 Specific drilling requirements are also available on request.
 Hinge in raw galvanised steel is made of pregalvanised steel.
 Therefore any cut surface is ungalvanised.

A	B	C	D	E	note	material	finish	part number	pin material	weight
2160	57	1.5	4	15	undrilled	galvanised steel	raw	40-1-4680	brass	2000g
2160	57	2	6	30	undrilled	galvanised steel	raw	40-1-4682	brass	2970g
2160	57	1.5	4	15	undrilled	304 stainless steel	raw	42-1-4220	stainless steel	2000g



Rolled knuckle continuous hinge 60mm open

Opening angle 270°. Other lengths and pin materials are available on request.
 Specific drilling requirements are also available on request.

A	B	C	D	E	F	G	S	note	material	finish	part number	pin material	weight
2000	60	1.5	5	40				undrilled	steel	raw	40-1-3541	steel	1980g
2000	60	1.5	8	40				undrilled	steel	raw	40-1-3335	steel	2600g
2040	60	2	6	30				undrilled	steel	raw	40-1-4371	steel	2800g
2000	60	2	6	30				undrilled	5754 alu	raw	41-1-3523	alu	998g
2040	60	2	6	30				undrilled	304 stainless steel	raw	42-1-3302	stainless steel	2800g
2040	60	2	6	30	35	60	4	drilled	304 stainless steel	raw	42-1-4201	stainless steel	2800g
2040	60	2	6	30				undrilled	316 stainless steel	raw	42-1-4002	stainless steel	2800g

Rolled knuckle continuous hinge 63mm open

new!

Opening angle 270°. Other lengths and pin materials are available on request.
 Specific drilling requirements are also available on request.

A	B	C	D	E	note	material	finish	part number	pin material	weight
1800	63	1.5	4	15	undrilled	304 stainless steel	raw	42-1-4221	stainless steel	1800g

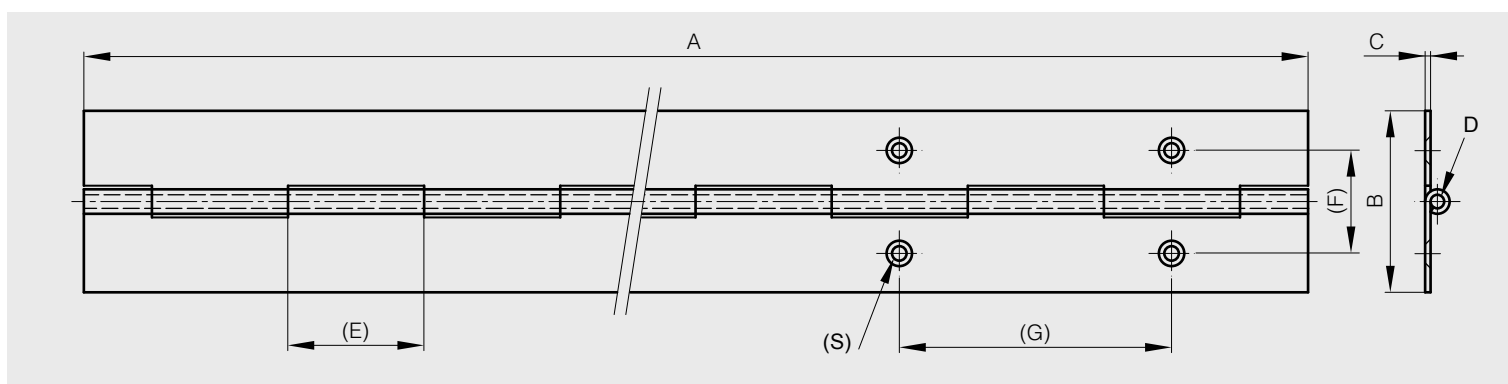



Hinges / Continuous hinge

Rolled knuckle continuous hinge 70mm open

Opening angle 270°. Other lengths and pin materials are available on request.
Specific drilling requirements are also available on request.

A	B	C	D	E	note	material	finish	part number	pin material	weight
2040	70	2	6	30	undrilled	steel	raw	40-1-4372	steel	3114g
1800	70	1.5	4	15	undrilled	304 stainless steel	raw	42-1-4097	stainless steel	1900g
2040	70	2	6	30	undrilled	304 stainless steel	raw	42-1-3859	stainless steel	3120g



Rolled knuckle continuous hinge 76mm open

new!

Opening angle 270°. Other lengths and pin materials are available on request.
Specific drilling requirements are also available on request.
Hinge in raw galvanised steel is made of pregalvanised steel.
Therefore any cut surface is ungalvanised.

A	B	C	D	E	note	material	finish	part number	pin material	weight
2160	76	1.5	4	15	undrilled	galvanised steel	raw	40-1-4681	brass	2400g
2160	76	1.5	4	15	undrilled	304 stainless steel	raw	42-1-4094	stainless steel	2400g

Rolled knuckle continuous hinge 80mm open

Opening angle 270°. Other lengths and pin materials are available on request.
Specific drilling requirements are also available on request.

A	B	C	D	E	note	material	finish	part number	pin material	weight
2000	80	2	7.6	40	undrilled	steel	raw	40-1-3542	steel	3900g
2000	80	3	6	40	undrilled	steel	raw	40-1-4369	steel	5060g
1000	80	3	6	40	undrilled	304 stainless steel	raw	42-1-3304	stainless steel	2530g
2000	80	3	6	40	undrilled	304 stainless steel	raw	42-1-3569	stainless steel	5060g

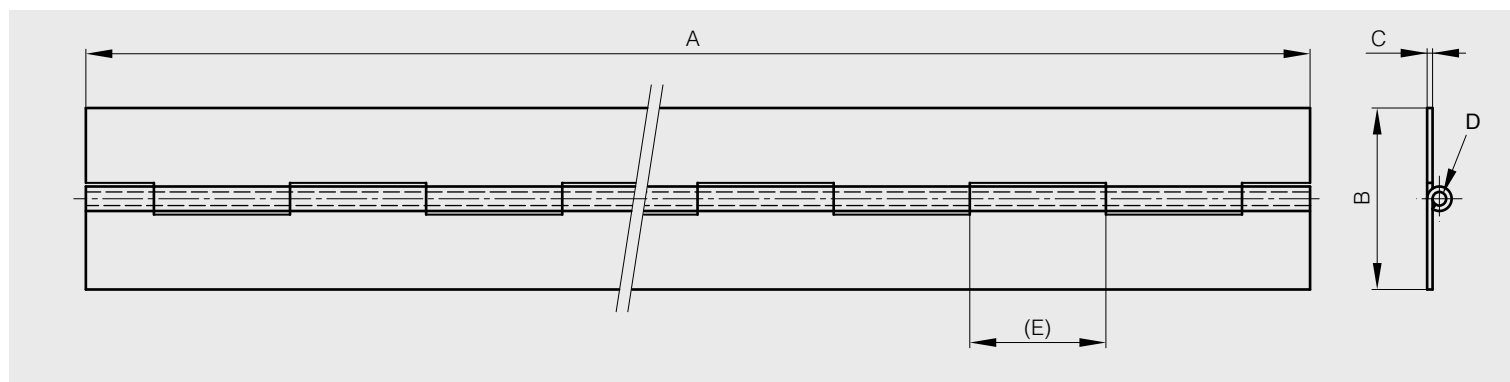



Hinges / Continuous hinge

Rolled knuckle continuous hinge 100mm open

Opening angle 270°. Other lengths and pin materials are available on request.
Specific drilling requirements are also available on request.

A	B	C	D	E	note	material	finish	part number	pin material	weight
2000	100	3	10	40	undrilled	steel	raw	40-1-3543	steel	7100g



Rolled knuckle continuous hinge 120mm open

new!

Opening angle 270°. Other lengths and pin materials are available on request.
Specific drilling requirements are also available on request.

A	B	C	D	E	note	material	finish	part number	pin material	weight
2100	120	2	6	30	undrilled	304 stainless steel	raw	42-1-4095	stainless steel	5000g

Rolled knuckle continuous hinge 127mm open

new!

Opening angle 270°. Other lengths and pin materials are available on request.
Specific drilling requirements are also available on request.
Hinge in raw galvanised steel is made of pregalvanised steel.
Therefore any cut surface is ungalvanised.

A	B	C	D	E	note	material	finish	part number	pin material	weight
2160	127	3	6	40	undrilled	galvanised steel	raw	40-1-4685	brass	8000g

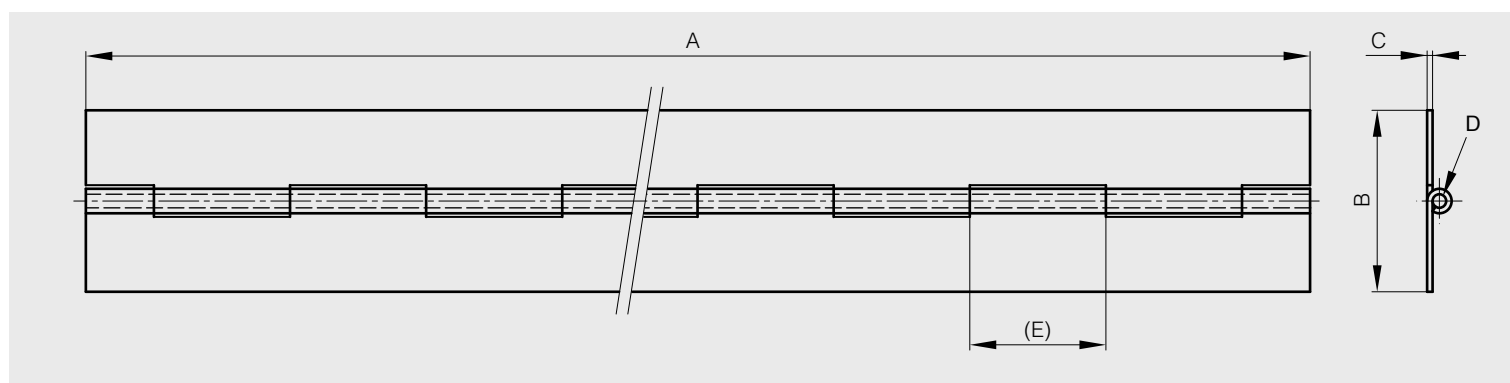



Hinges / Continuous hinge

Drilled continuous hinge with one cranked leaf

Opening angle 270°. Other lengths and pin materials are available on request.
Specific drilling requirements are also available on request.

A	B	C	D	E	F	G	H	S	note	material	finish	part number	weight
1000	31.5	1	2	30	7.5	60	20	3.5	drilled	steel	zinc plated	39-1-3302	430g
2000	31.5	1	2	30	7.5	60	20	3.5	drilled	steel	zinc plated	39-1-3631	860g
2000	31.5	1	2	30	7.5	60	20	3.5	drilled	304 stainless steel	raw	39-1-3630	860g

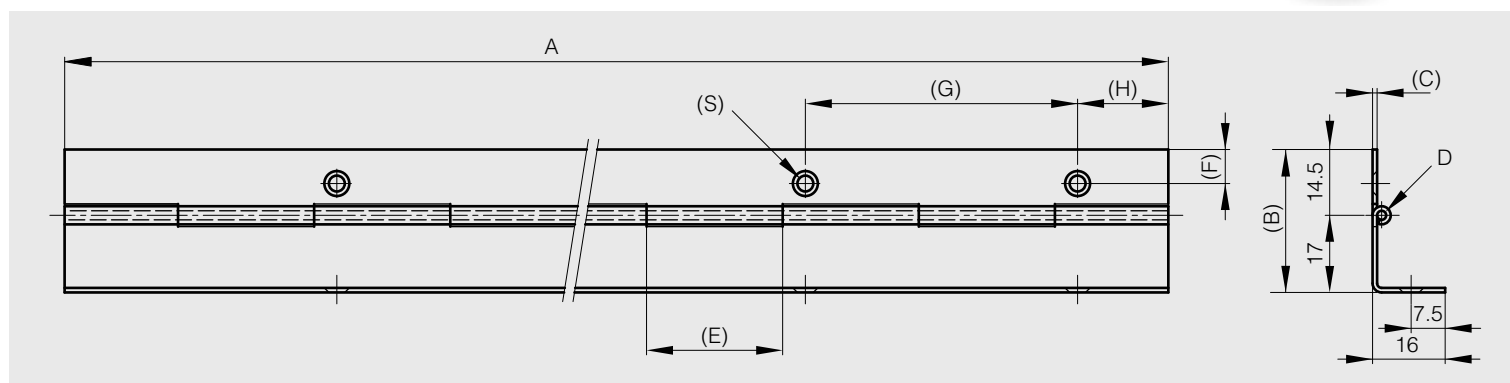

Undrilled continuous hinge with one cranked leaf

Opening angle 270°. Other lengths and pin materials are available on request.
Specific drilling requirements are also available on request.

A	B	C	D	E	note	material	finish	part number	weight
2000	44	1.5	3	25	undrilled	steel	zinc plated	39-1-3632	1756g
1600	44	1.5	3	25	undrilled	430 stainless steel	raw	39-1-3300	1430g
2000	44	1.5	3	25	undrilled	304 stainless steel	raw	39-1-3633	1787g

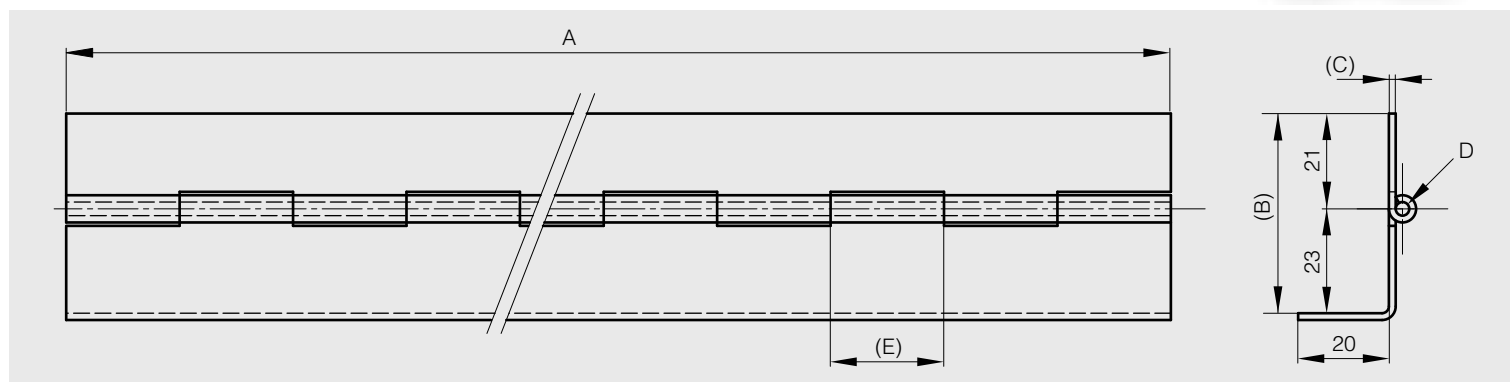



Hinges / Continuous hinge

Continuous hinge with two cranked leaves

Opening angle 270°. Other lengths and pin materials are available on request.
Specific drilling requirements are also available on request.

A	B	C	D	E	note	material	finish	part number	pin material	weight
2000	46	1.5	3	25	undrilled	steel	zinc plated	39-1-3634	304 stainless steel	1910g
2000	46	1.5	3	25	undrilled	304 stainless steel	raw	39-1-3635	304 stainless steel	1944g

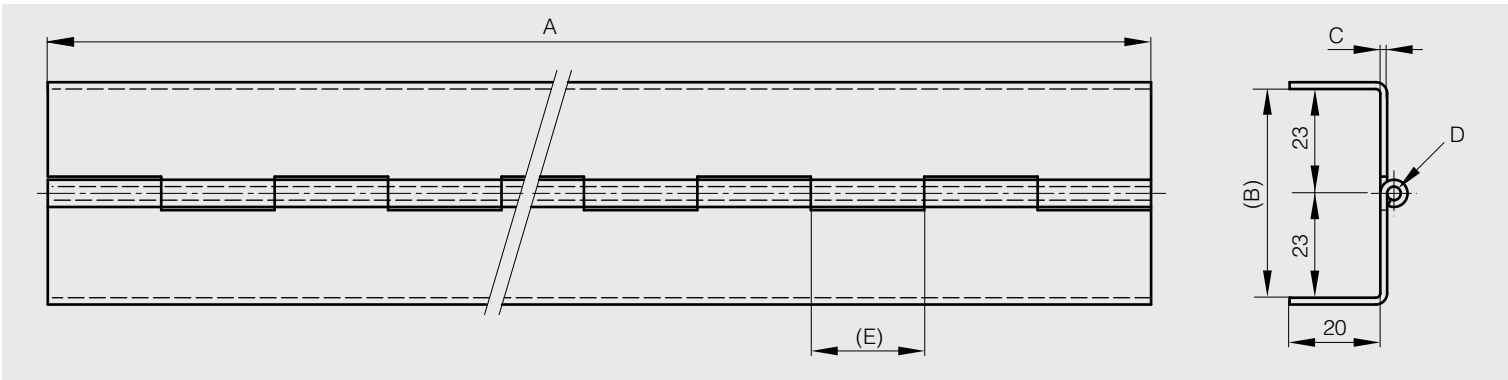

Aluminium profile continuous hinge - 50mm open

Opening angle 270°. Other lengths are available on request.
Specific drilling requirements are also available on request.

A	B	C	D	E	note	material	finish	part number	pin material	weight
2000	50	3	5.2	35.5	undrilled	alu 6060 T5	raw	72-1-3316	304 stainless steel	1200g

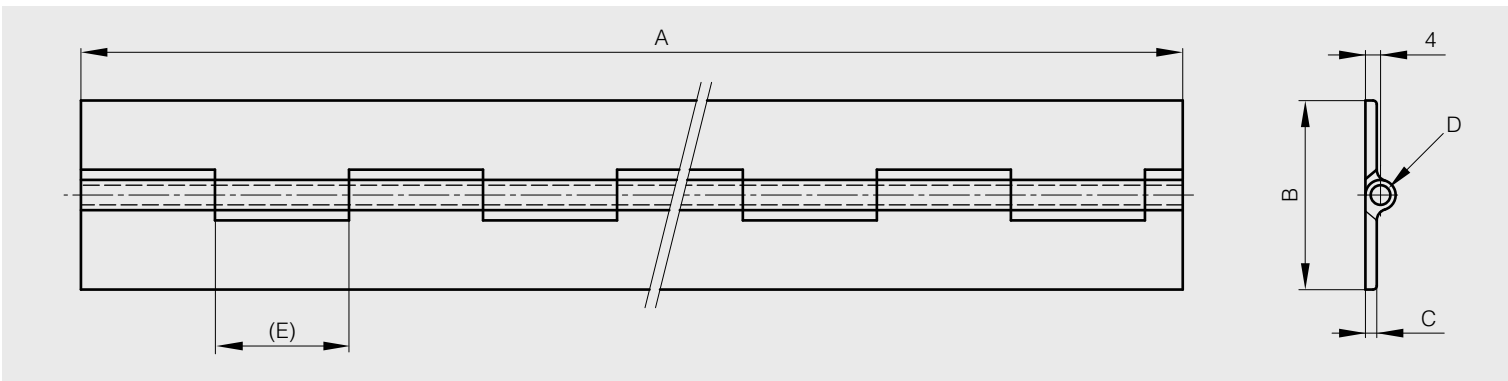



Hinges / Continuous hinge

Double knuckle continuous hinge

Hinge in aluminium profile for 180° opening angle.
 Delivered without watertight gasket (to be ordered separately).
 With fixed friction washers
 Non-drilled hinge.



A	D	K	material	finish	part number	pin material	weight
2000	5	65	alu 6060 T5	clear anodised	73-1-3520	304 stainless steel	2500g
2500	5	15	alu 6060 T5	clear anodised	73-1-3521	304 stainless steel	3140g
3000	5	115	alu 6060 T5	clear anodised	73-1-3522	304 stainless steel	3780g

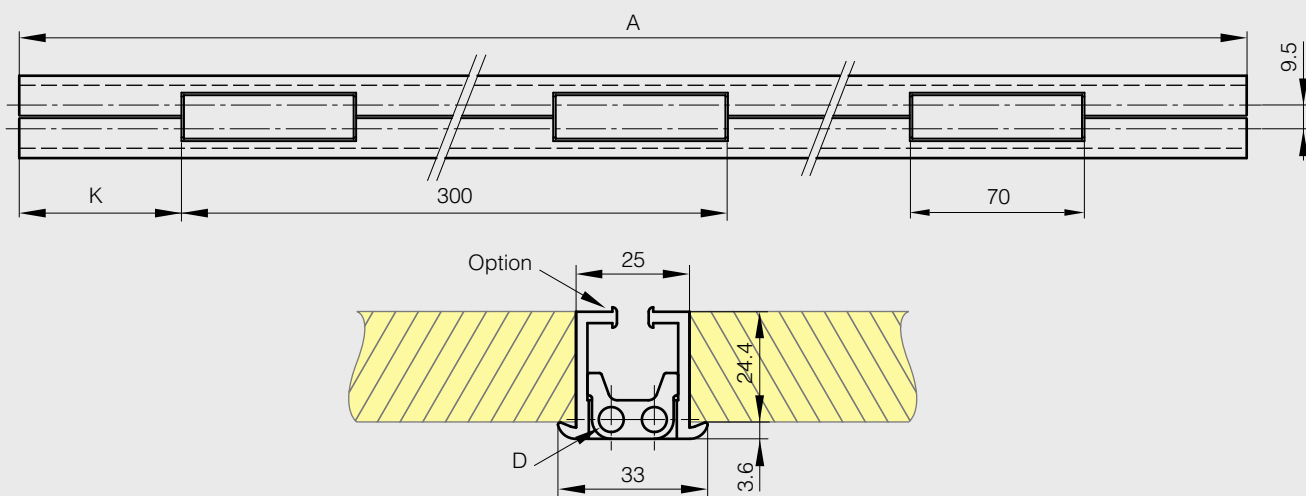

Seal gasket for double knuckle continuous hinge

Gasket made of soft rubber with a steel clip-on core and foam rubber

A	material	part number
2000	reinforced rubber profile	27-1-3816
2500	reinforced rubber profile	27-1-3817
3000	reinforced rubber profile	27-1-3818

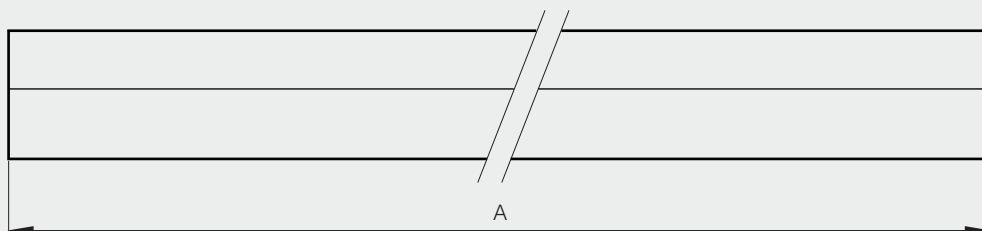



Hinges / Continuous hinge

Continuous plastic hinge in 15,25 meter rolls

Technical features :

- Temperatures: -40°C up to +80°C
- Can be fixed with: rivets, screws, nails or clamps
- Chemical resistance : oil, solvents, sea water and most chemical agents
- Tensile resistance : 180N/cm
- Material offers excellent fatigue resistance



B	C	material	finish	part number	weight
28.6	3.2	polypropylene	white	44-7-3000	1050g
28.6	3.2	polypropylene	grey	44-7-3001	1050g
28.6	3.2	polypropylene	black	44-7-3002	1050g
38.1	3.2	polypropylene	white	44-7-3003	1450g
38.1	3.2	polypropylene	grey	44-7-3004	1450g
38.1	3.2	polypropylene	black	44-7-3005	1450g
50.8	3.2	polypropylene	white	44-7-3006	2300g
50.8	3.2	polypropylene	grey	44-7-3007	2300g
50.8	3.2	polypropylene	black	44-7-3008	2300g
76.2	3.2	polypropylene	white	44-7-3009	2900g
76.2	3.2	polypropylene	grey	44-7-3010	2900g
76.2	3.2	polypropylene	black	44-7-3011	2900g

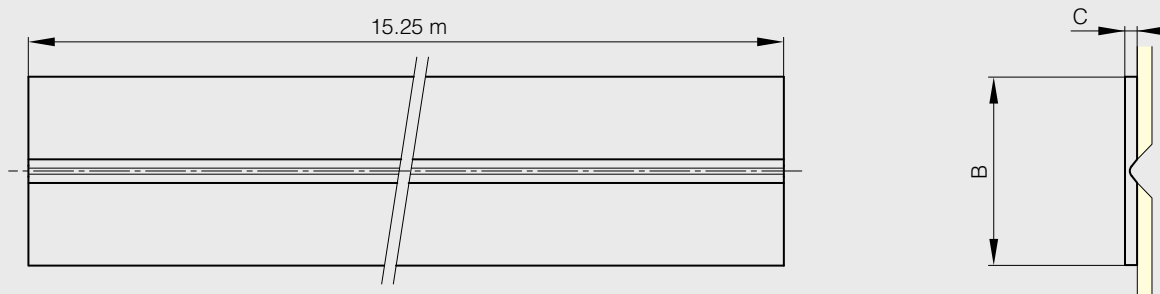

Rolled knuckle continuous hinges «Imperial» dimension

A	B	C	D	E	note	material	finish	part number	weight
6'	1"	0.04"	0.08"	5/8"	undrilled	304 stainless steel	raw	42-1-4096	500g
6'	1" 1/4	0.04"	0.08"	5/8"	undrilled	304 stainless steel	raw	42-1-4089	500g
6'	1" 1/4	3/64"	1/8"	3/4"	undrilled	304 stainless steel	raw	42-1-4346	790g
6'	1" 1/2	3/64"	1/8"	3/4"	undrilled	304 stainless steel	raw	42-1-4347	940g
6'	2"	3/64"	1/8"	3/4"	undrilled	304 stainless steel	raw	42-1-4348	1100g
6'	2"	1/16"	5/32"	5/8"	undrilled	304 stainless steel	raw	42-1-4219	1500g
7'	2" 1/4	1/16"	5/32"	5/8"	undrilled	304 stainless steel	raw	42-1-4220	2000g
6'	2" 1/2	1/16"	5/32"	5/8"	undrilled	304 stainless steel	raw	42-1-4221	1800g
6'	2" 3/4	1/16"	5/32"	5/8"	undrilled	304 stainless steel	raw	42-1-4097	1900g
7'	3"	1/16"	5/32"	5/8"	undrilled	304 stainless steel	raw	42-1-4094	2400g
7'	5"	0.08"	1/4"	1" 1/4	undrilled	304 stainless steel	raw	42-1-4095	5000g

