

Sealed compact magnetic catch

new!

This reference is associated with counterplate 16-7-4205

A	B	force	part number	material	finish	weight
45	17	3kg	16-7-4204	plastic	white	9g

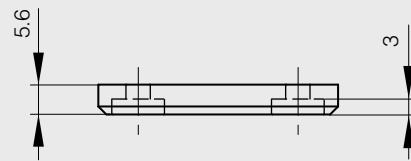
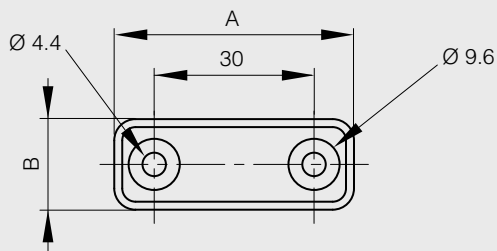

Counterplate for sealed magnetic catch 16-7-4204

new!

The non magnetic side of this counterplate is indicated with a blue dot. This counterplate has the same dimensions as the part listed above.

A	B	part number	material	finish	weight
45	17	16-7-4205	plastic	white	9g

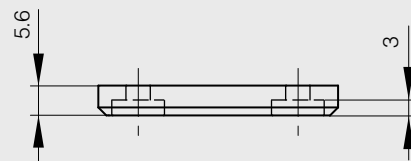
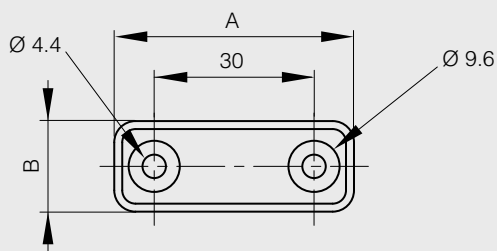

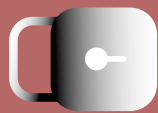

Sealed magnetic catch

A	B	C	D	force	part number	material	finish	weight
50	21	13	40	3kg	16-7-4081	plastic	white	21g
50	21	13	40	3kg	16-7-4206	plastic	black	21g

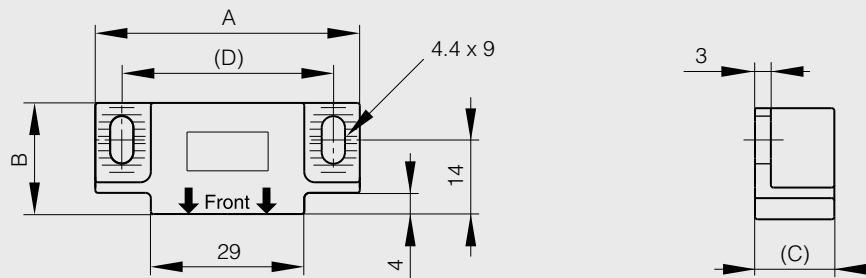

Counterplate for sealed magnetic catch 16-7-4081 and 16-7-4206

A	B	C	D	part number	material	finish	weight
49	15	2	40	16-7-4082	316 stainless steel	raw	10g

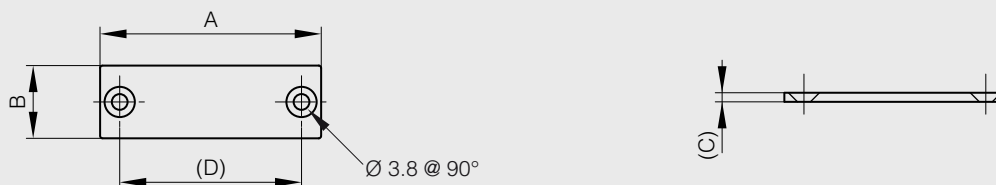

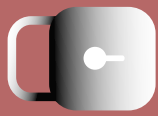

Ultra thin compact magnetic catch

Suitable for temperatures below 80°C
To avoid breakage, counterplate should not connect with magnet.
Screw heads should not protrude above the base plate.

A	B	force	part number	material	finish	weight
35	12	2.7kg	16-7-4033	steel	nickel plated	4g

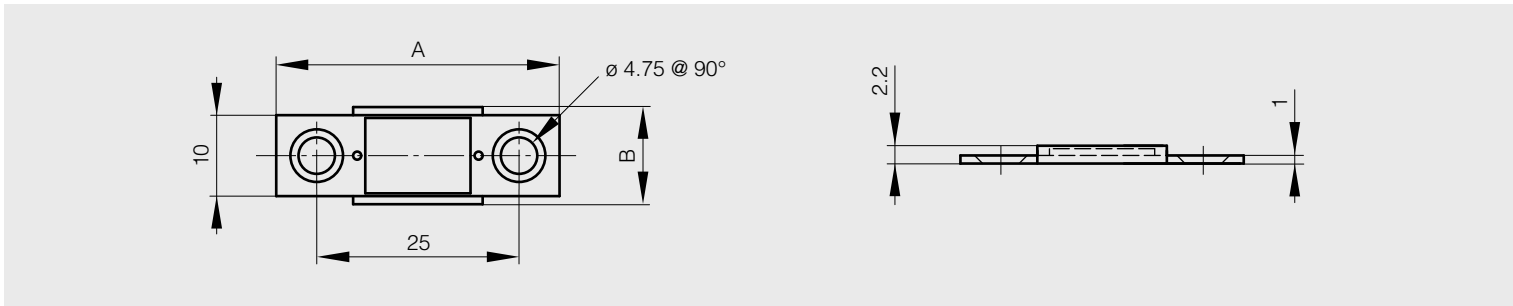

Compact magnetic catch

new!

Suitable for temperatures below 80°C
To avoid breakage, counterplate should not connect with magnet.
Screw heads should not protrude above the base plate.

A	B	force	part number	material	finish	weight
41	16.5	4kg	16-7-4207	steel	nickel plated	12g

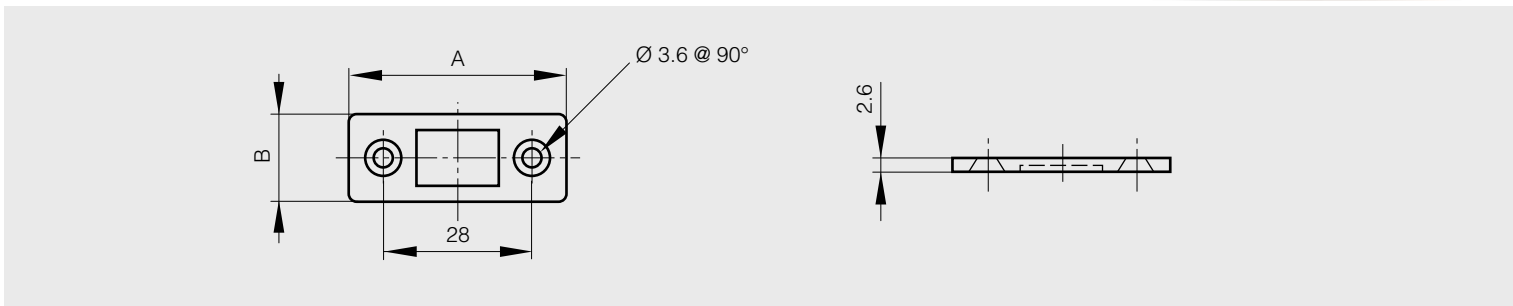



Screw-on magnetic catches without counterplate

A	B	C	D	force	part number	material	finish	weight
48.5	16.5	13	39	4kg	16-7-3372	plastic	white	18g
53.5	16.5	13.5	39	4kg	16-7-3388	plastic	white	24g

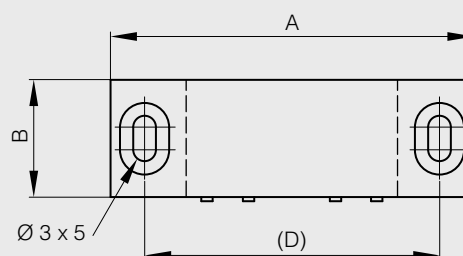
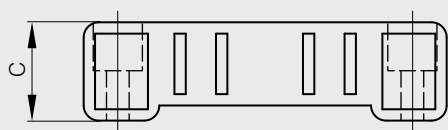

Counterplates for magnetic catches 16-7-3372 and 16-7-3388

A	B	C	D	note	part number	material	finish	weight
50.5	14	4.5	40	for part number 16-7-3372	16-7-3648	plastic	white	6g
58	15	4.5	48	for part number 16-7-3388	16-7-3649	plastic	white	7.5g

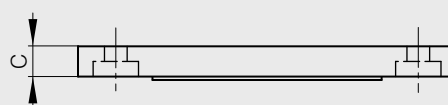
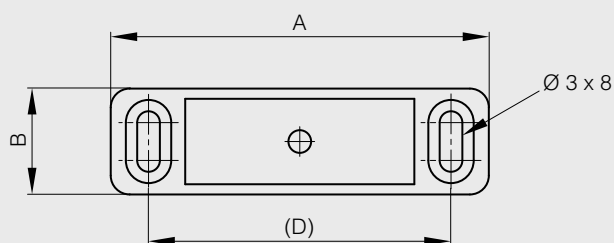

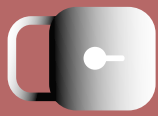

Screw-on sealed magnetic catch with counterplate

A	B	C	force	part number	material	finish	weight
39.8	13.7	11.7	2 to 3kg	16-7-3492	plastic	white	16.5g

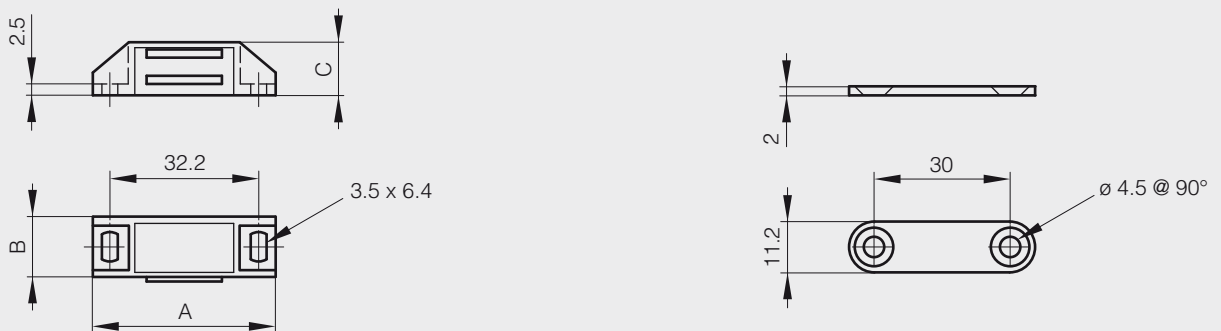

Screw-on sealed magnetic catch without counterplate

A	B	C	D	force	part number	material	finish	weight
48	15	19.2	38	4kg	16-7-3390	plastic	white	13g

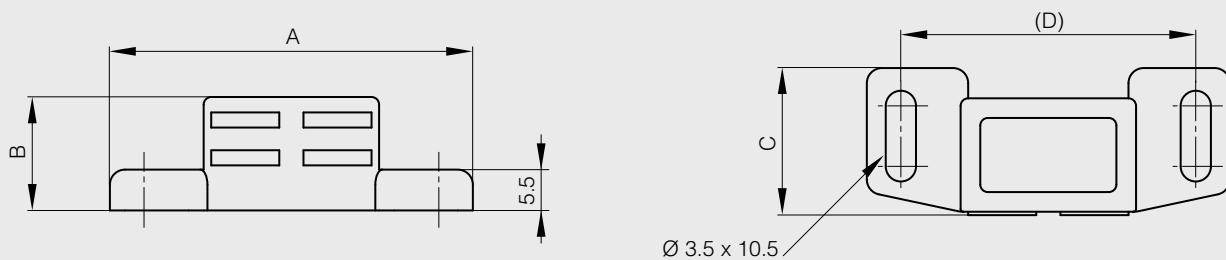



Counterplate for magnetic catch 16-7-3390

A	B	C	D	S	part number	material	finish	weight
41	14	1.5	31	3	16-7-3351	steel	zinc plated	6g

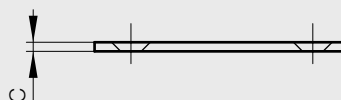
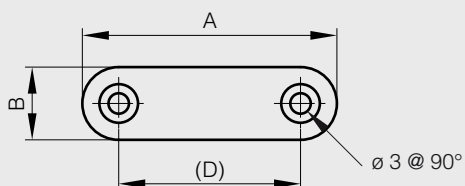

Screw-on magnetic catches with counterplate

A	B	C	force	note	part number	material	finish	weight
49.4	16.4	15.6	4kg	temperature up to 80°C	16-7-3494	zinc die-cast	nickel plated	56g
49.4	16.4	15.6	4kg	temperature up to 300°C	16-7-3610	zinc die-cast	nickel plated	56g

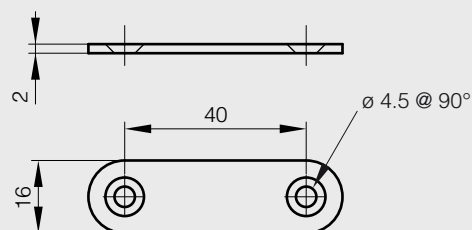
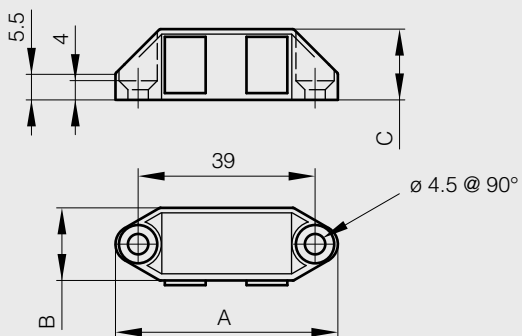

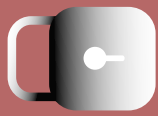

Screw-on sealed magnetic catches with counterplate

A	B	C	force	part number	material	finish	weight
54	16	15	4kg	16-7-3483	zinc die-cast	nickel plated	49g



430 stainless steel magnet

A	B	C	D	E	F	G	H	force	part number	material	finish	weight
86	13	15	77	12	57	70	9.2	4.8kg	16-7-3861	plastic	white	100g
105.3	16	18	94	14	65	79	11.4	5.6kg	16-7-3862	plastic	white	100g

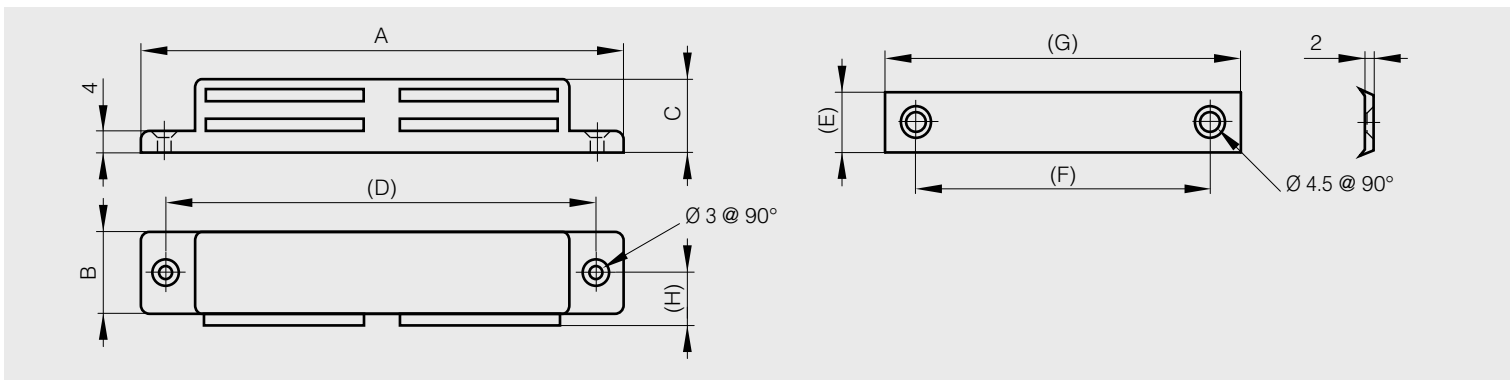



Screw-on magnetic catches with counterplate

Forces valid with the related counterplate.

A	B	C	C1	C2	D	E	F	G	S1	S2	force	part number	material	finish	weight
56	12	15.2	5	5	40	15.5	57	42	3.2x5	7	3kg	16-7-3486	plastic	white	23.5g
58	12	15.2	5	5	42	15.5	57	42	3.2x6	8.1	4kg	16-7-3487	plastic	white	31g
62.1	12.6	15.2	6	5.5	45	16.4	62	44.7	3.2x6	8.1	6kg	16-7-3488	plastic	white	41g

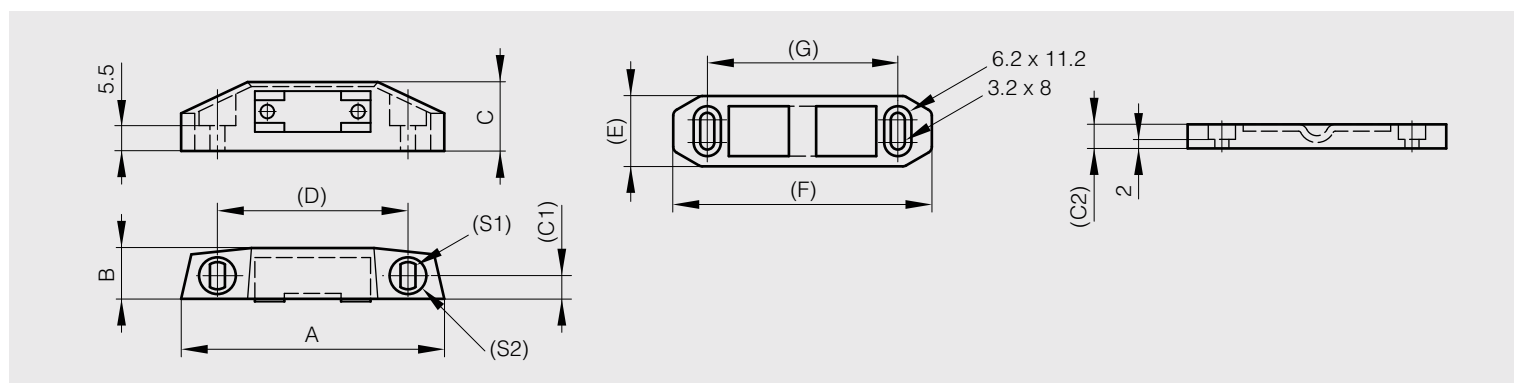

Screw-on magnetic catches with counterplate

A	B	C	force	note	part number	material	finish	weight
86	16.4	15.6	8kg	temperature up to 80°C	16-7-3391	zinc die-cast	nickel plated	112g
86	16.4	15.6	8kg	temperature up to 300°C	16-7-3611	zinc die-cast	nickel plated	112g

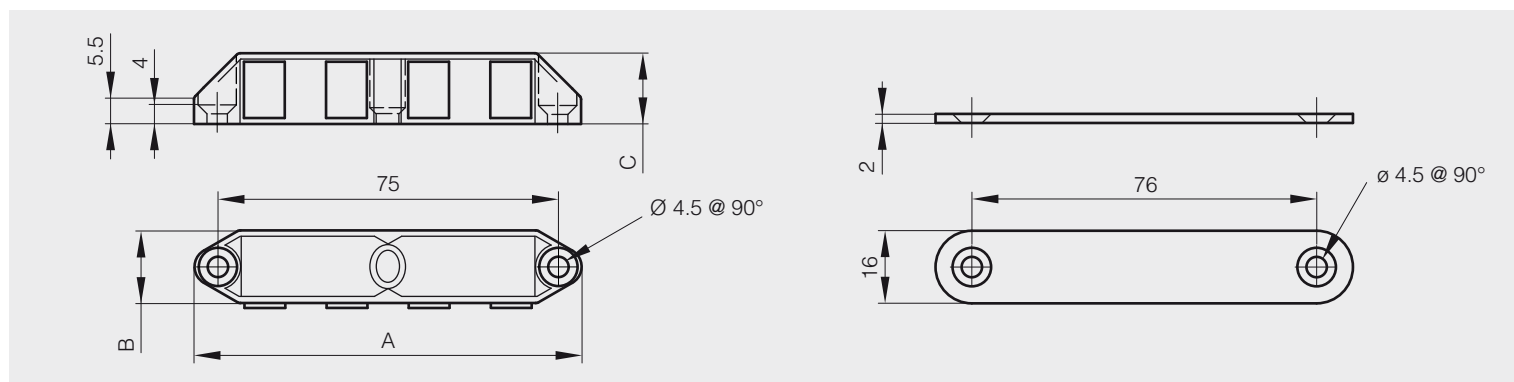

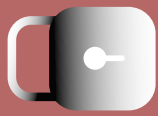

Screw-on sealed magnetic catch without counterplate

A	B	C	D	force	part number	material	finish	weight
74	14	17.5	64	12kg	16-7-3672	plastic	white	37g

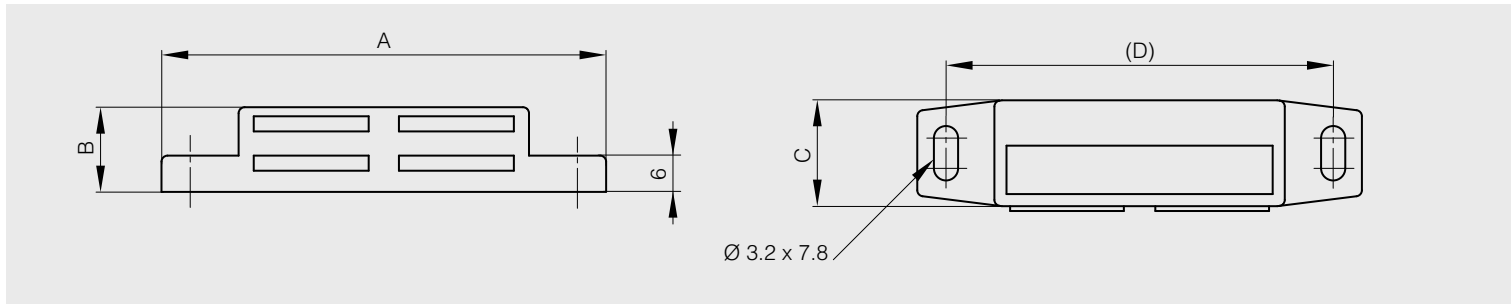

Counterplate for magnetic catch 16-7-3672

A	B	C	D	part number	material	finish	weight
66	12	2	54	16-7-3673	steel	zinc plated	11g

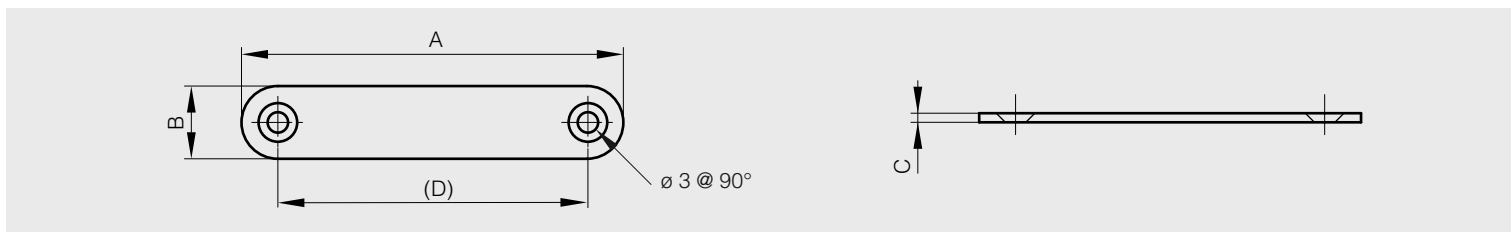



Snap-in magnets

new!

Snap-in magnets for sheet metal applications. Suitable for material thicknesses 1.6mm or 2.6mm.
 E denotes material thickness.
 Cut-out varies to suit metal thickness.
 Flex-tab for easy removal.

A	B	C	force	part number	material	finish	weight
41	13	14.6	1.2kg	16-7-4208	plastic	black	5g
41	13	14.6	3kg	16-7-4209	plastic	black	5.5g

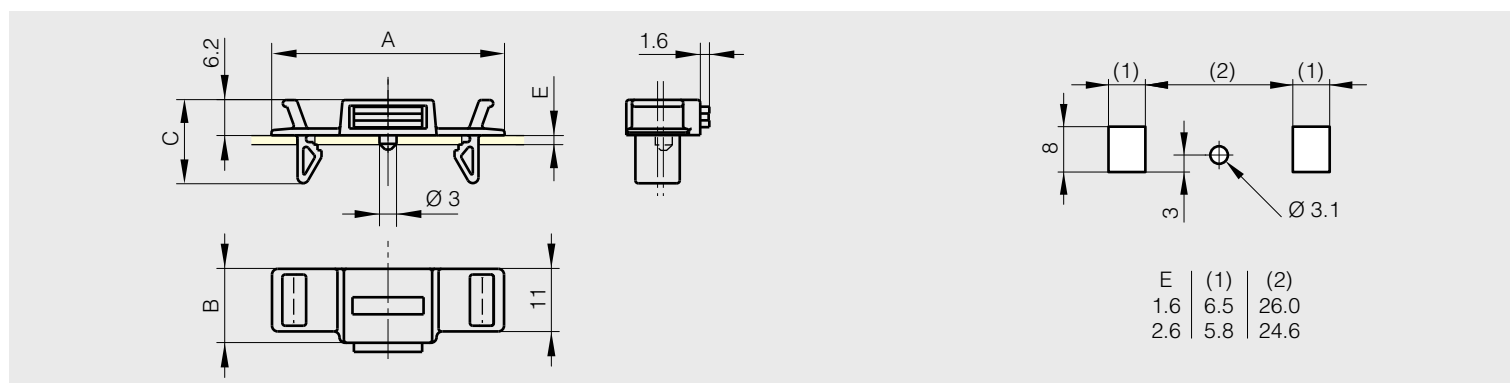

A	B	C	D	E	force	note	part number	material	finish	weight
25.5	12.3	10.4	23	11	1.5kg	for sheetmetal thickness 1.5mm	16-7-4013	polypropylene	white	4g
25.5	9.6	11	23	8.2	1.8kg	for sheetmetal thickness 1.5mm	16-7-4014	polypropylene	white	4g
39.5	10	11	35	8.2	4kg	for sheetmetal thickness 1.5mm	16-7-4015	polypropylene	white	8g
54	12.5	14.5	51.5	10.8	15kg	for sheetmetal thickness 2.0mm	16-7-3674	polypropylene	black	32g

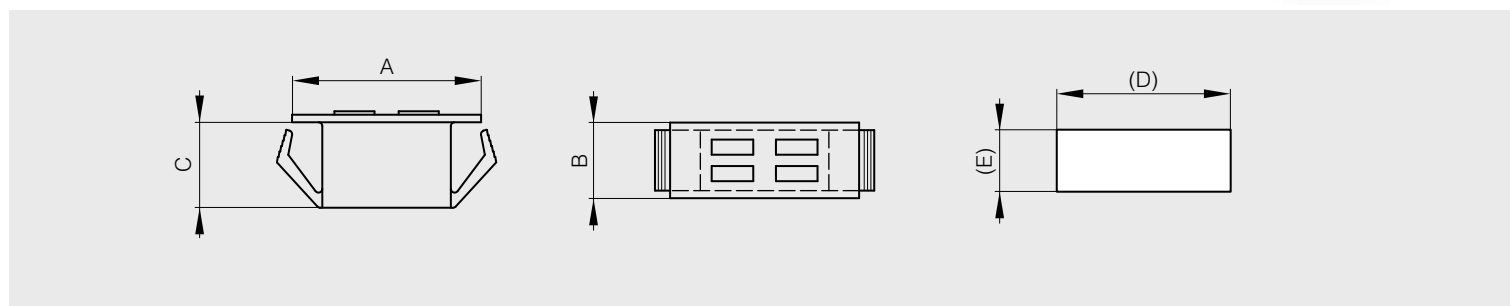

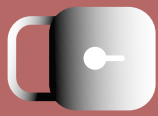

Counterplates for snap-in magnets

A	B	C	D	note	part number	material	finish	weight
41	14	1.5	31	for pt. nos. 16-7-4013 and 16-7-4014	16-7-3351	steel	zinc plated	6g
66	12	2	54	for pt. nos. 16-7-3674 and 16-7-4015	16-7-3673	steel	zinc plated	11g

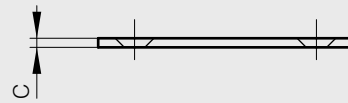
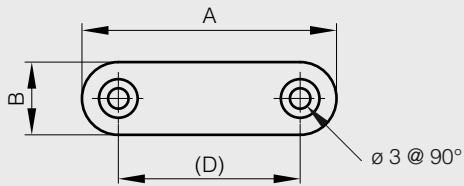

Housing

Housing for part number 16-7-3674

A	B	C	D	part number	material	finish	weight
75.5	14.8	18.5	65	16-7-3675	plastic	black	8g

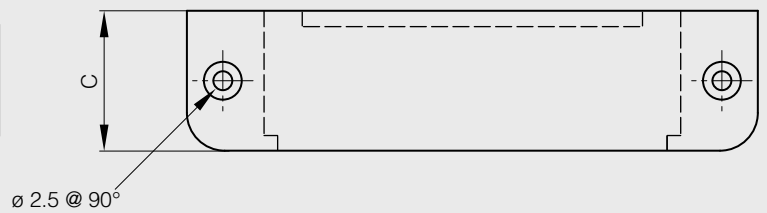
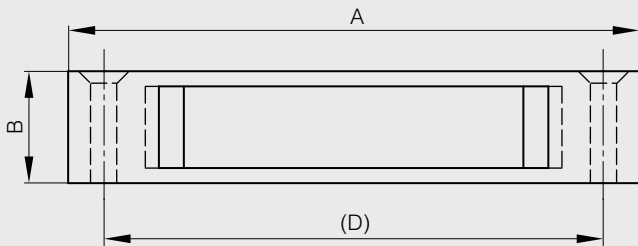



Flush magnet with high temperature resistance

A	B	C	D	force	note	part number	material	finish	weight
56	16.3	16.7	42	4kg	temperature up to 150°C	16-7-3484	zinc die-cast	nickel plated	63.5g

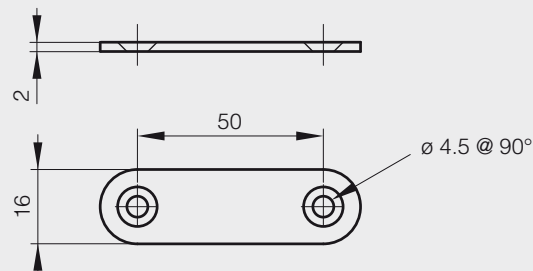
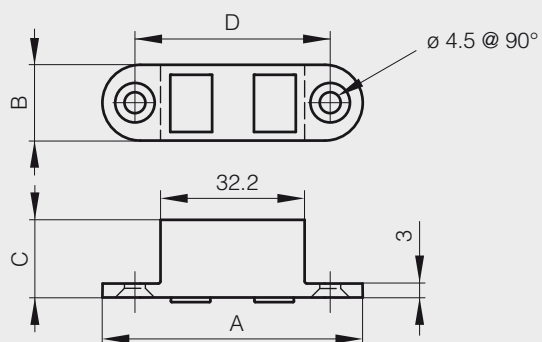



Flush compact catches without counterplate

A	B	D	force	part number	material	finish	weight
24	15	13.5	5kg	16-7-3387	steel	zinc plated	13g



A	B	D	force	part number	material	finish	weight
24	12	13.5	4.2kg	16-7-3378	steel	zinc plated	14g



Flush compact catch without counterplate offering high temperature resistance

Temperature resistance up to 250°C

A	B	D	Force	part number	material	finish	weight
26	12	13.5	4.2kg	16-7-3490	steel	zinc plated	17.5g
29	16	17.5	8kg	16-7-3651	steel	zinc plated	40g

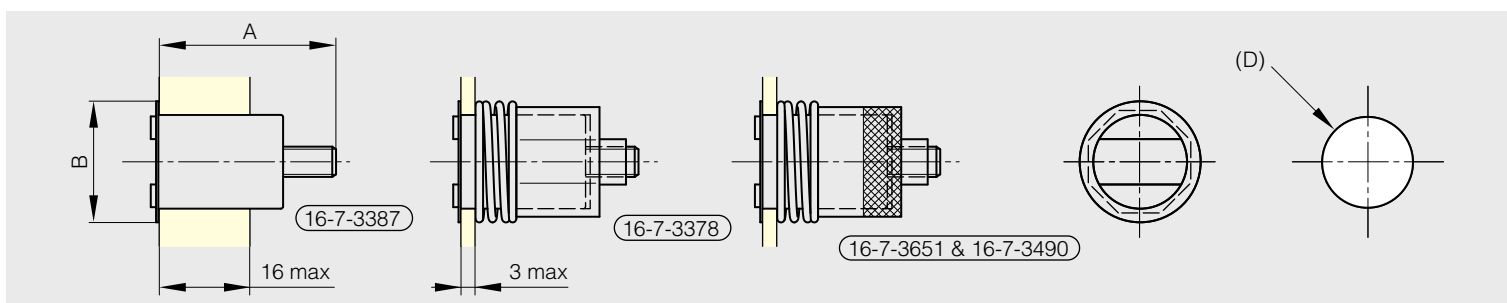



Counterplate for part numbers 16-7-3378, 16-7-3387, 16-7-3490 and 16-7-3651

A	B	part number	material	finish	weight
15.1	3	16-7-3349	steel	zinc plated	4g

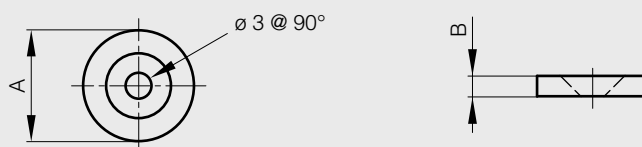

Flush magnetic catch without counterplate

A	B	C	D	force	part number	material	finish	weight
53	14.2	15.5	44	7kg	16-7-3373	plastic	white	26g

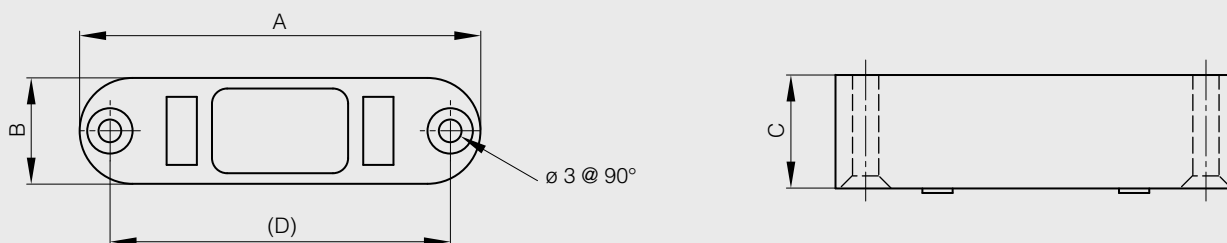

Counterplate for part number 16-7-3373

A	B	C	D	part number	material	finish	weight
53.5	15	6.5	43.5	16-7-3352	plastic	white	13g

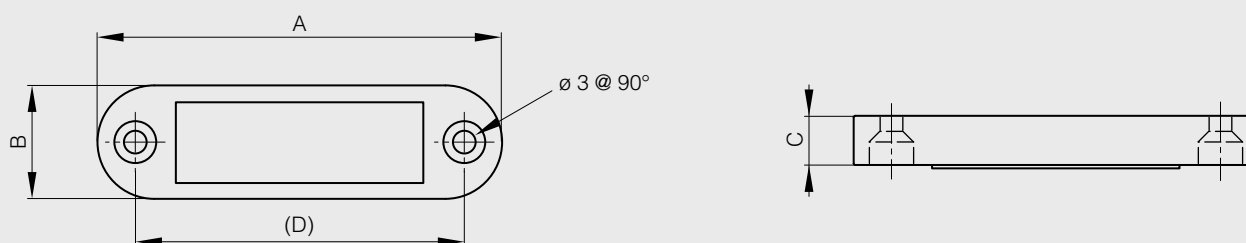

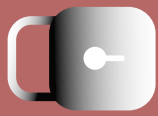

Self-adhesive magnetic profile

Available in 30 meter rolls.
Heat resistance : 100°C

B	C	force	part number	material	finish	weight
19	1.5	55 grs/cm ²	16-7-3682	flexible magnet	self adhesive	3300g

