



2012

## **COOLANT PUMPS MAIN CATALOGUE**

COOLING, LUBRICATING,  
RINSING, MAINTAINING TEMPERATURES ...



## *Story*



BRINKMANN PUMPS represents over 60 years of the highest quality and reliability made in Germany. More than 130 employees worldwide in engineering, research and development and production worldwide work on customer specific solutions with the same goal: exceeding our customers' expectations with every pump.

From a small centrifugal coolant pump for external cooling to the rugged lifting and cutter pumps to the high pressure screw spindle pumps, BRINKMANN PUMPS is the only supplier to cover all your coolant pump needs. Performance and reliability of our pumps over many decades has machine tool designers and manufacturers worldwide convinced of our unsurpassed quality and service.

## *Engineering*

Each BRINKMANN Pump is embedded with often many years of research, including internal and external product development and in-house and field testing.

Being directly in contact with our global customer base, we can continuously deliver innovations and market driven pump solutions. For example, our patented quick suctioning immersion pumps, which are uniquely capable of handling coolants with a high percentage of air-entrainment.

In order to provide custom solutions in a cost effective way, we have developed a highly sophisticated modular design system. This system allows us to quickly and economically develop and customize application specific products for each customer.



	Page
Recommendations to choose Coolant Pumps	4
Technical Information	
Electrical, Mechanical and Hydraulic Features	5 – 8
Control / Regulation	9 – 11
Potentials for energy savings	12
DESINA	13
Lifting pump versions	14 – 16
Pumps with changeable flanges	17
Immersion Pumps TB16 ... STA4500	18 – 39
Semi-open impellers <b>Standard coolant pumps</b> 25 ... 5000 l/min 4 ... 120 m	
Quick Suctioning Immersion Pumps with BRINKMANN's Suction De-aeration System TL50 ... SAL2500	40 – 57
Axial/semi-open impellers <b>Inflated fluids / slurping</b> 25 ... 2600 l/min 5 ... 115 m	
Quick Suctioning Immersion Pumps with BRINKMANN's Suction De-aeration System TGL331 ... 501 SGL331 ... 2200	58 – 67
Axial/semi-open impellers <b>Inflated grinding oils / slurping</b> 25 ... 2600 l/min 5 ... 90 m	
Quick Suctioning Immersion Pumps with BRINKMANN's Suction De-aeration System SFL650 ... 2350	68 – 69
Axial/semi-open impellers <b>Inflated coolants / slurping</b> <b>heavy chip loads</b> 25 ... 2500 l/min 5 ... 46 m	
Cutter Pumps with cutting units SFC 820 ... 2320 SBC 820 ... 1120	70 – 71 108 – 109
Axial - radial impellers <b>Large chips</b> 25 ... 1800 l/min 4 ... 45 m	
Free-flow Immersion Pumps/Vortex Pumps FT35 ... FTA140 SFT450 ... 3554	72 – 77
Semi-open impellers <b>Large chips</b> 25 ... 2500 l/min 4 ... 20 m	
Suction Immersion Pumps Lifting Pumps TAS301 ... 601 / STS1001 TAA70 ... 280	78 – 81
Axial/semi-open impellers <b>Vacuum filter / lifting</b> 25 ... 1200 l/min 4 ... 60 m	
Horizontal End-Suction Pumps BAL/SBA141 ... 2000 BGL/SBG501 ... 1700 BFL/SBF550 ... 1850	82 – 109
Axial - radial impellers <b>Coolant Lubricants / cutting oils</b> <b>increased chip load</b> 25 ... 2250 l/min 5 ... 62 m	
Immersion Pumps TS12 ... TM26	110 – 111
Peripheral impellers <b>High pressure in compact units</b> 10 ... 70 l/min 25 ... 140 m	
Immersion Pumps Pressure Boosting Pumps TC25 ... 460 (S)TH2 ... FH14	112 – 163
Closed impellers <b>High pressure / no long chips</b> 10 ... 600 l/min 30 ... 520 m	
Immersion Pumps in Plastics KTF25 ... 303 KTB200	164 – 167
Semi-open impellers <b>Coldwater circuits</b> 15 ... 400 l/min 4 ... 42 m	
Miniature Centrifugal Pumps Suction Pumps KC21 ... SB60	168 – 171
Open/peripheral impellers <b>Suctioning / circulating</b> 2 ... 60 l/min 10 ... 45 m	
Immersion Pumps / Miniature Centrifugal Pumps TB40-M ... 100-M B401 ... 501 BMK3 ... BMK4	172 – 173 174 – 177
Open/semi-open/peripheral impellers <b>Maintaining temperatures</b> 10 ... 100 l/min 5 ... 65 m	
High Pressure Immersion Pumps BFS1 ... TFS6 FFS1 ... FFS6	178 – 181
Screw spindles <b>High pressure</b> 2.6 ... 878 l/min 10 ... 150 bar	
Questionnaire	183
Notes	184





# Recommendations to choose Coolant Pumps



Series	Application											Medium						Pollution		Proportion of air in the fluid		Performance		Page				
	boring	sawing	milling	turning	grinding	eroding	circulating	tempering	cooling	washing	emulsions	coolants and lubricants	grinding oils	thermal oils	dielectric	water	de-ionized water	less / solvents	coarse	medium	few	normal	increased		lifting	washing	pressuring	
TB16 ... 100	●	●	●	●	●	○	●				●	●	●	○	○		○		●	●	●		●	●		18–19		
TA160 ... 600	●	●	●	●	●	○	●	○	○	○	●	●	●	●	○		○		●	●	●	●		●	●	●	20–21	
TE/STE141 ... 146	●	●	●	●	●	○	●	○	○	○	●	●	●	○	○		○		●	●	●		●	●	●	22–23		
TA/STA301 ... 306	●	●	●	●	●	○	●	○	○	○	●	●	●	●	○		○		●	●	●	●		●	●	●	24–25	
STA401 ... 4500	●	●	●	●	●	○	●	○	○	○	●	●	●	●	○		○		●	●	●	●		●	●	●	26–39	
TL50 ... TAL200	●	●	●	●	●	○	●	○	○	○	●	●	●	○	○		○		●	●	●	●	●	●	●	●	40–41	
TL/STL141 ... 146	●	●	●	●	●	○	●	○	○	○	●	●	●	○	○		○		●	●	●	●	●	●	●	●	42–43	
TAL/SAL301 ... 306	●	●	●	●	●	○	●	○	○	○	●	●	●	○	○		○		●	●	●	●	●	●	●	●	44–45	
SAL401 ... 2500	●	●	●	●	●	○	●	○	○	○	●	●	●	○	○		○		●	●	●	●	●	●	●	●	46–57	
TGL/SGL331 ... 2200	●	●	●	●	●	○	●	○	○	○	●	●	●	○	○		○		●	●	●	●	●	●	●	●	58–67	
SFL650 ... 2350	●	●	●	●	●	○	●	○	○	○	●	●	●	○	○		○		●	●	●	●	●	●	●	●	68–69	
SFC820 ... 2320	●	●	●	●	●	○	●	○	○	○	●	●	●	○	○		○		●	●	●	●	●	●	●	●	70–71	
SBC820 ... 1120	●	●	●	●	●	○	●	○	○	○	●	●	●	○	○		○		●	●	●	●	●	●	●	●	108–109	
FT35 ... FTA140	●	●	●	●	●	○	●				●	●	●	●	○		○		●	●		●		●	●		72–73	
SFT450 ... 3554	●	●	●	●	●	○	●		○		●	●	●	●	○		○		●	●		●		●	●		74–77	
TAS301 ... 601	●	●	●	●	●	○	●				●	●	●	●	○		○		●	●	●	●		●	●	●	78–79	
STS1001	●	●	●	●	●	○	●				●	●	●	●	○		○		●	●	●	●		●	●	●	78–79	
TAA70 ... 280	●	●	●	●	●	○	●				●	●	●	●	○		○		●	●	●			●	●		80–81	
BAL/SBA141 ... 2000	●	●	●	●	●	○	●	○	○	○	●	●	●	○	○		○		●	●	●		●	●	●	●	84–95	
BGL/SBG501 ... 1700	●	●	●	●	●	○	●	○	○	○	●	●	●	○	○		○		●	●	●	●		●	●	●	96–103	
BFL/SBF550 ... 1850	●	●	●	●	●	○	●	○	○	○	●	●	●	○	○		○		●	●	●	●		●	●		104–107	
TS12 ... 24	●	●	●	●	●	○	●	○	○	○	●	●	●	●	○	○	○			●	●			●	●		110–111	
TM24 ... 26	●	●	●	●	●	○	●	○	○	○	●	●	●	●	○	○	○			●	●			●	●		110–111	
TC25 ... 160	●	●	●	●	○	○	●	○	○		●	●	●	●	○	○		○	●	●				●	●		112–119	
(S)TH2 ... 14	●	●	●	●	○	○	●	○	○	○	●	●	●	●	○	○	○		○	●	●				●	●	122–141	
FH2 ... 14	●	●	●	●	○	○		○	○	○	●	●	●	●	○	○	○		○	●	●				●	●	142–161	
TC260 ... 460	●	●	●	●	○	○	●	○	○	○	●	●	●	●	○	○	○		○	●	●				●	●	162–163	
KTF25 ... 83						○	●	○	●		●	○		○	●	○				●	●			●	●	●	164–165	
KTF151 ... 303						○	●	○	●		●	○		○	●	○					●	●			●	●	●	166–167
KTB200						○	●	○	●		●	○		○	●	○					●	●			●	●	●	166–167
KC21 ... 60	○	○	○	○		○	●	○	○	○		●	○	○	●	○	○			●	●			●	●		168–169	
SB20 ... 60	●	●	●	●	○	○	●	○	○	○	●	●	●	○	○	○	○		○	●	●				●		170–171	
TB40-M ... 100-M							●	●	○			●	●	○	○	○	○		●	●	●				●		172–173	
B401 ... 501						○	●	●	○	○	●	○	○	●	○	○	○			●	●				●	●	174–175	
BMK3 ... BMK4						○	●	●	○	○	●	○	○	●	○	○	○			●	●				●	●	176–177	
BFS1 ... TFS6	●	●	●	●	○						●	●	●	○						●	●				●	●	178–181	
FFS1 ... FFS6	●	●	●	●	○						●	●	●	○						●	●				●	●	178–181	

● usable      ○ please ask before choice



## Electrical Features



### Motors acc. to EN 60034

Grade of protection	IP55
Type of insulation	F
Number of poles	2
Efficiencies	EN 60034-30, IE2 ≥ 0.75 kW

	50 Hz		60 Hz	
	220 V – 240 V Δ 380 V – 420 V Y	380 V – 420 V Δ	265 V Δ 460 V Y	460 V Δ
up to 5,5 kW	Standard	●	●	●
7,5 kW – 10 kW	●	Standard	●	●
as of 11 kW	–	Standard	–	●

The voltage tolerance is ±5% in keeping with DIN EN 60034-1.

Special voltages are available upon request:

	200 V	380 V	400 V	415 V	440 V	480 V	500 V	575 V	230 V YY 460 V Y
50 Hz	●	●	●	●	–	–	●	–	–
60 Hz	●	●	●	–	●	●	–	●	●

- Upon request

Other voltages upon request.

Motor sizes of 10 kW are delivered with thermistors as standard.

For the connection of 60 Hz, as well as the choice of the corresponding motor winding, the company will also adapt the hydraulics, e. g. with smaller impellers or dummy stages.

For specialized demands, versions for use with a standardized voltage 50 and 60 Hz (Transformer usage) are possible after consultation with the company, e. g. 3 x 400 V, ± 5 %, 50 – 60 Hz.

### Motors as of 7.5 kW

Motor design permits Y / Δ -starting.

Y / Δ -starting is not obligatory for centrifugal pumps. Screw-spindle pumps for Y / Δ -starting must be started without pressure. Soft-starting devices are an alternative to Y / Δ -starting.

### Switching-on frequency

Motors less than 3 kW:  
maximum 200 times per hour.

Motors from 3 kW to 5.5 kW:  
maximum 40 times per hour.

Motors from 7.5 kW to 10 kW:  
maximum 20 times per hour.

Motors 11 kW and higher:  
maximum 15 times per hour.

Alternative starting frequency is possible upon request.

### Non-European Regulations

Motors up to 10 kW and up to max. 600 V are available as special designs with cUL-certification.

Approval testing is carried out by the Underwriters Laboratories Inc. according to the UL 1004 Electric Motors Standard. The motor's rating plate bears the identification:



„Recognized Component Mark for Canada and the United States“.

Motors larger than 10 kW are available upon request with approval testing.

Additional country-specific approvals upon request.

### Comparison of motor efficiency classes worldwide

Efficiency Class	New	Europe	North America, Australia, New Zealand
Super premium efficiency	IE4	–	–
Premium efficiency	IE3	–	NEMA Premium
High efficiency	IE2		EPAct
Standard efficiency	IE1		–
Below standard efficiency	–		–

IE = International Efficiency

## Electrical Features



### Circuits

#### Standard voltage changing Y / Δ

e. g. 220–240 / 380–420 V, 50 Hz

Δ (Delta Connection)    Y (Star Connection)

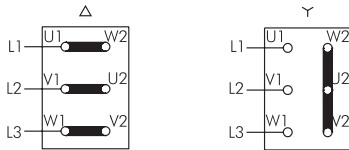

#### Optional

#### Pole-changing motor 4/2 poles Y/Y Y

for 50 % reduced revolutions to choice

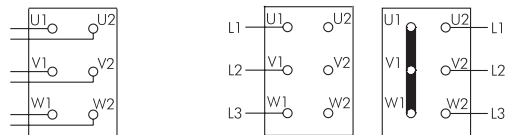

Dahlander circ.

(1500 RPM)

(3000 RPM)

Y / Y Y  
with pole-switch

4-poles Y    2-poles Y Y  
without pole-switch

#### Voltage changing 1 : 2 Y Y / Y

e. g. 230 / 460 V, 60 Hz

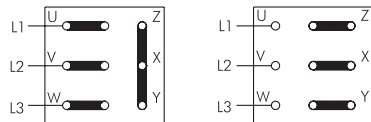

Y Y  
Low Voltage

Y  
High Voltage

#### Optional

#### Connection to single-phase

e. g. 1 x 230 V, 50 Hz:

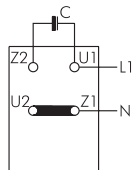

0.045 kW single-phase  
capacitor 5 μF 400 V DB

0.055 kW single-phase  
capacitor 5 μF 400 V DB

0.075 kW single-phase  
capacitor 5 μF 400 V DB

0.14 kW single-phase  
capacitor 5 μF 400 V DB

0.22 kW single-phase  
capacitor 10 μF 400 V DB

0.28 kW single-phase  
capacitor 12 μF 400 V DB

### Set-up altitude and coolant temperature

The specified power ratings ( $P_N$ ) and operating values for the motors apply for operating mode S 1 according to EN 60034-1 (continuous operation) at a frequency of 50 Hz, rated voltage, a cooling air temperature (KT) of max. 40 °C and a set-up altitude of up to 1000 m above sea level. The motors can also be used at a cooling air temperature above 40 °C up to max. 60 °C or set-up altitude above 1000 m above sea level. In such cases the power rating must be reduced according to the diagrams, or an appropriately larger motor version or higher heat class has to be selected. However, a deviation from the specified data is necessary when the cooling air temperature is reduced according to table simultaneously at set-up altitudes higher than 1000 m above sea level.

Set-up altitude / m	Maximum cooling air temperature for heat class F / °C
0 up to 1000	40
1000 up to 2000	30
2000 up to 3000	19
3000 up to 4000	9

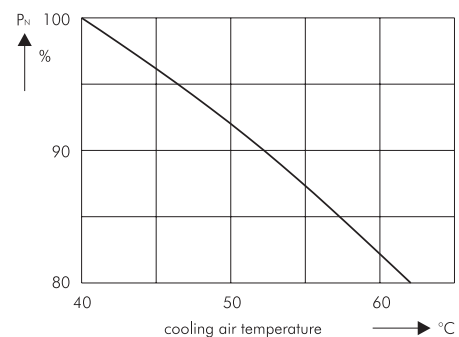
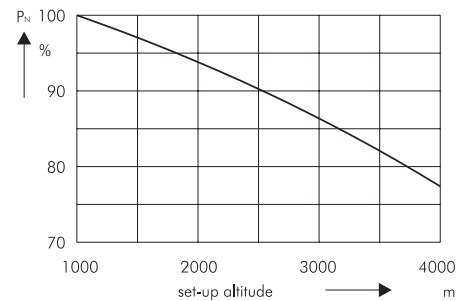

### Noise Levels

The noise levels stated in the catalog are valid for 50 Hz operation. For 60 Hz operation the noise levels are approximately 3 – 4 dBA above those stated. For reduced noise levels special axial motor fan blades are available upon request.

### Name Plates

Standard motors according to the IE2 standard are supplied with a second name plate with 60 Hz ratings.

## Mechanical/Hydraulic Features



### Terminal Box Position acc. to EN 12157

In accordance with EN 12157 the terminal box is positioned above the outlet on immersion and suction pumps:

Position 1 is the standard design for immersion pumps, position 2 for suction

pumps, and position 3 for miniature centrifugal pumps.

If a non-standard position is required, please specify details when ordering.

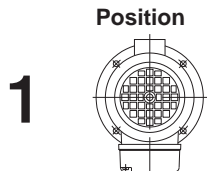

### Motor top view

Terminal box opposite pump discharge. Standard version for immersion pumps.

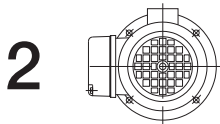

Terminal box on the left of the pump discharge. Standard set-up for suction pumps. For Horizontal End-Suction pumps please refer to page 83.

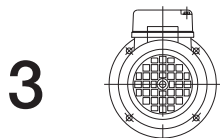

Terminal box over the pump discharge. Standard version for miniature centrifugal pumps.

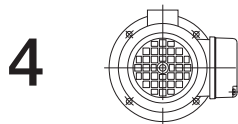

Terminal box on the right of the pump discharge.

### Lacquering

Standard RAL 9005  
Other colors available upon request and at an additional cost.

### Immersion-depth extension

Immersion depths of the TC and TH pumps can be extended by dummy stages to any immersion depth available in the series without having to change the electrical and hydraulic power.

Example: The pumping rate of the TC63/350 pump is required at an immersion depth of 750 mm.  
Solution: TC63/350 – 750

### Leakage chamber / Leakage connections

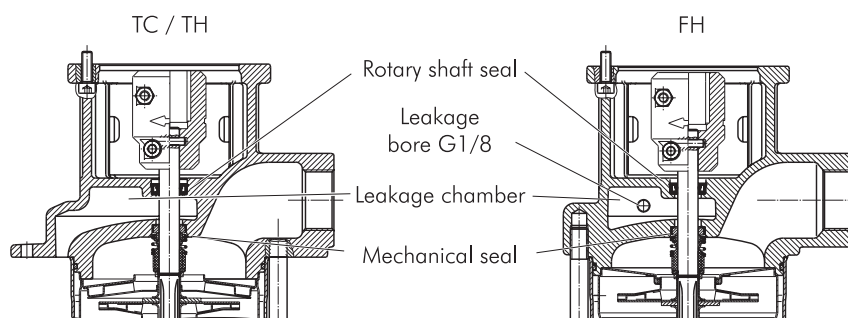

Small leaks flow back through the leakage chamber into the tank without reaching the outside.

By connecting a leakage line it is possible to conduct minor leaks back into the tank.



## Hydraulic Features



BRINKMANN's program of coolant pumps offers appropriate design strategy for different applications.

Based upon the **centrifugal pump system**, we offer **immersed pumps with open, semi-open and closed impellers** for different coolants.

Patented quick suctioning pumps series **TL, SAL, SFL, SGL** are provided for **extreme suctioning** of inflated coolants loaded with air.

Vortex pumps series SFT and lifting pumps series SFL are **suitable for coolants with heavy chip loads**.

Suction immersion pumps Series TAS/STS make it possible to connect to vacuum filters because of their single connection on the suction side (for instance, with a slot screen).

Lifting pumps series TAA pump foam-sensitive cooling lubricants.

Immersion pumps series TC, TH for medium pressure get **optimal hydraulic efficiency** due to their **closed impellers**; simple pre-filtration is recommended.

High pressure in coolant systems is provided by **screw pumps using longwearing silicon carbide housings**. Please ask for further applications by informing us about working conditions in your devices.

Please note that with all immersion pumps, the **highest fill level of coolant should stay a few inches below the fastening flange**.

The **pump characteristics, shown in this brochure, apply to water at 20° C (1 mm<sup>2</sup>/s)**. Rising viscosity needs more power of the motor. Coolants of specific weight less than 1 need less, more than 1 need more power of the motor.

Centrifugal pumps pressure is stated as delivery head in metres (m).

The diagrams of immersion pump types STA404; with semi-open impellers, and TC63/560, with closed impellers, show the rates for coolants of different viscosities and different specific weights in m and bar respectively.

**Noise levels refer to 50 Hz operation.**

The viscogram shows examples of oils in common use. If required, viscograms can be supplied for oils of any viscosity and pump you currently use.

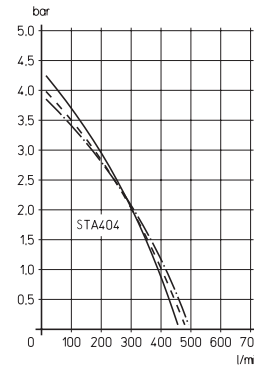
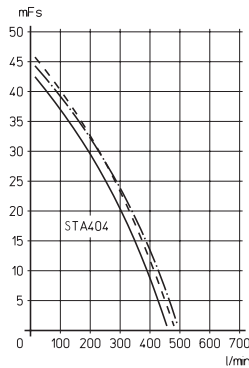

STA404 with semi-open impellers

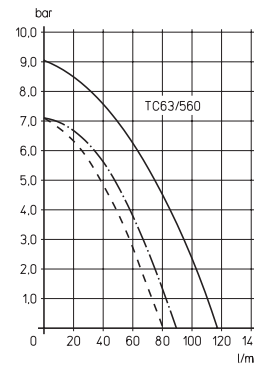
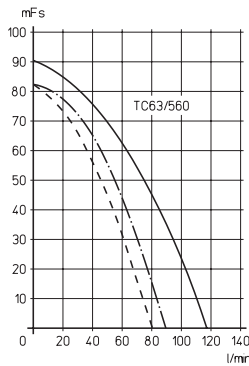

TC63 with closed impellers

Water ———  
 Oil - - - - 45 mm<sup>2</sup>/s spec. weight  
 Oil - · - · - 90 mm<sup>2</sup>/s 0,87

Water ———  
 Oil - - - - 45 mm<sup>2</sup>/s spec. weight  
 Oil - · - · - 90 mm<sup>2</sup>/s 0,87

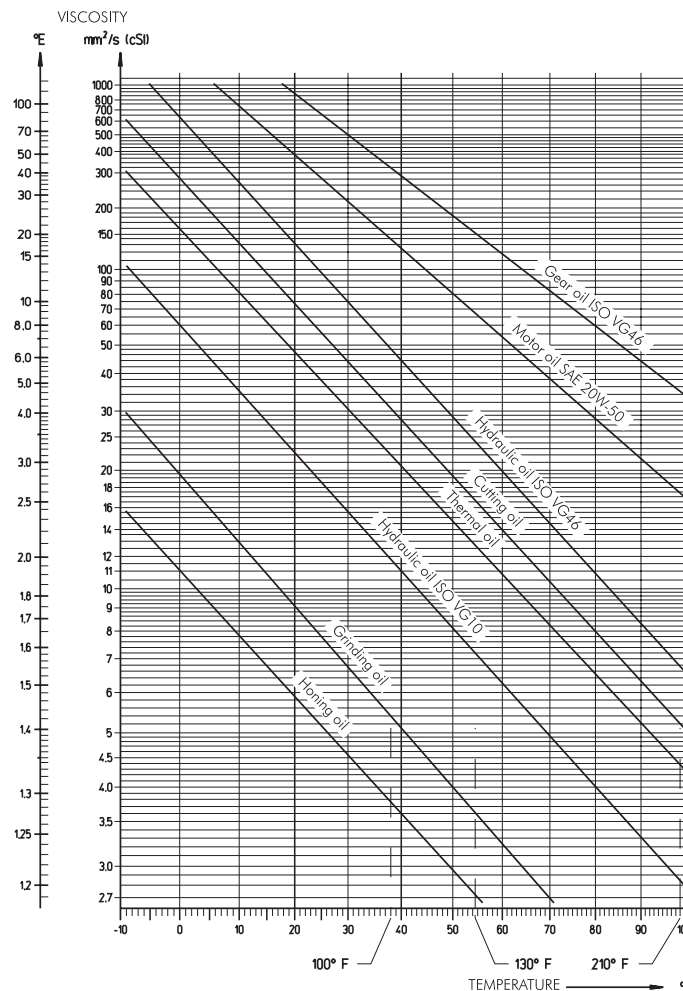

### Brinkmann coolant pumps with frequency converter 1.3 ... 55 kW

Pumps with integrated frequency converter offer the optimum supplement to the existing product line for your application.



With the use of a frequency converter the Q/H curve otherwise typical for centrifugal pumps, is replaced by a performance map. This makes it possible to regulate the pump to various operating points within the performance map, allowing the pump to be optimally matched to your specific application.

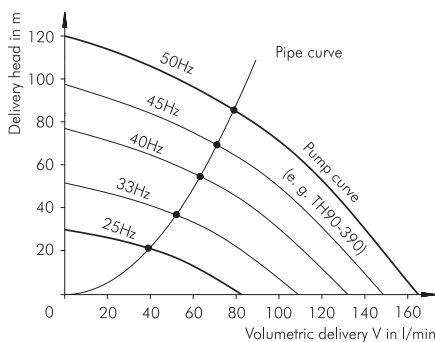

Fig. 1: Performance map

#### Advantages of pumps with frequency converter:

- Reduction of switch cabinet space requirement
- No shielded leads required (EMC problems)
- Optimum adaptation to various applications
- Low heat transfer to medium (dimensional stability)
- Energy-saving

### Pump control

Control is an operation in which a physical value such as pressure or flow rate is influenced by other values.

With a control we also speak of an open effective circuit, because the effect of the control is not monitored.

Interferences occurring in the system cannot be compensated, because the output value has no effect on the input value.

Pumps with integrated frequency converter are always supplied preprogrammed by the manufacturer.

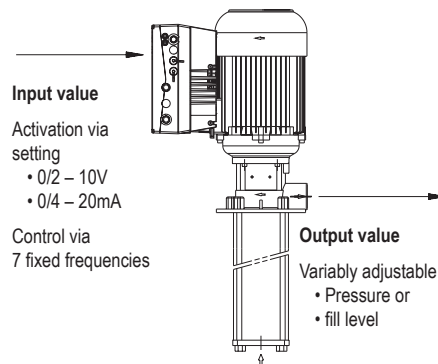

Fig. 2: Control scheme

### 1. Pump control via analog signal

When the coolant pump is controlled by using a frequency converter, nearly an infinite number of various pressures can be achieved for different tools, for example.

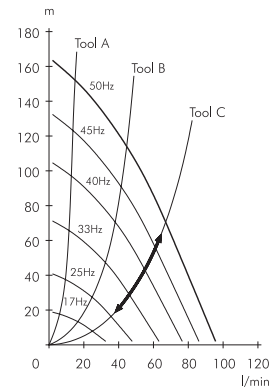

Fig. 3: Analog signal (infinite)

Usually the layout of the pump is limited to the 50 Hz version. Operation at higher frequencies is possible for various pumps with power reserves after conferring with the company.

The frequency converter is then operated at the current limit. This means the motor is operated at the set motor current rating at maximum. If the pump requires more motor power for the operating point, the frequency is reduced until the max. motor current is again achieved.

### 2. Pump control via fixed frequencies (max. 7)

An alternative to analog pump control is digital control of the frequency converter over 3 digital inputs. Here up to 7 different fixed frequencies can be set.

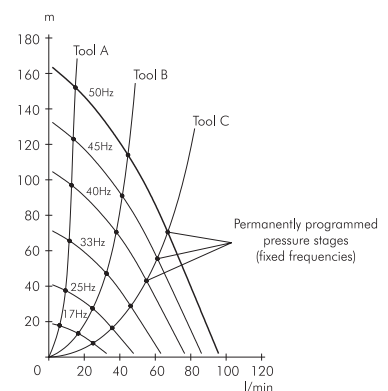

Fig. 4: Fixed frequencies

With fixed frequency control it is possible to realize special pressure stages with one certain tool.



### 3. Pump regulation

Regulation is an operation with which a physical value such as pressure is continuously sensed and compared with a set value. In the event of deviation the regulation device (here a PI controller) provides for the desired adaptation.

With regulation a check is made of whether a desired state is achieved. This allows a previously set pressure to be held constant within certain ranges in a process regardless of the quantities supplied.

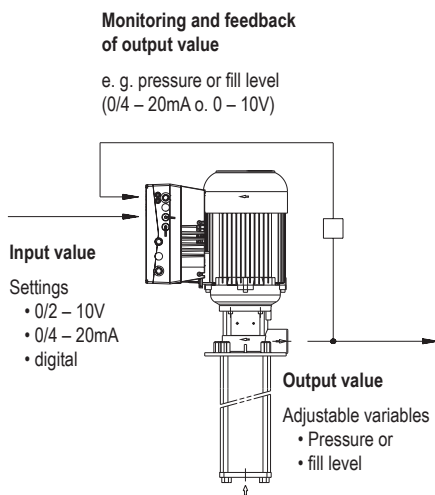

Fig. 5: Scheme of regulation

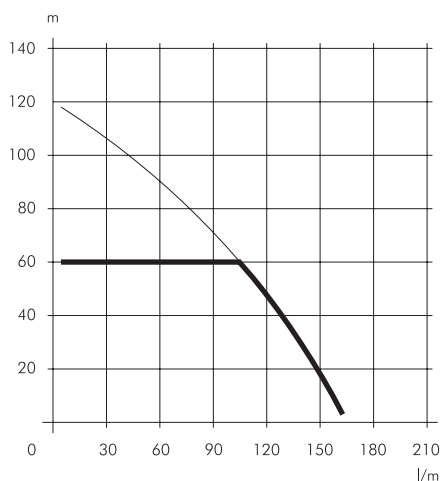
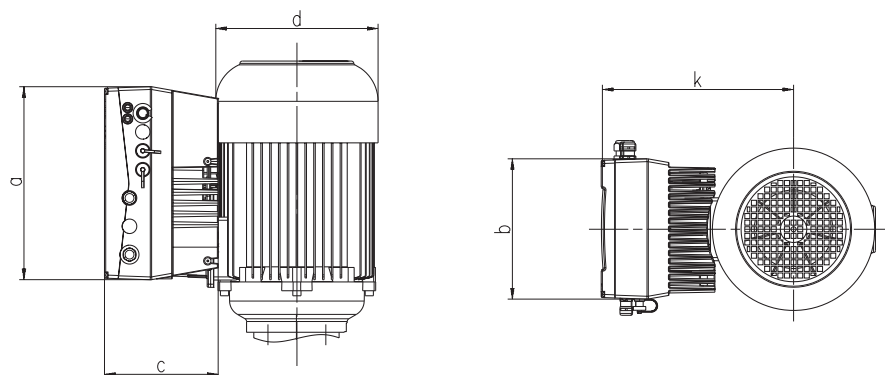

Fig. 6: Pressure regulation limited to max. 6 bar

TECHNICAL DATA Series FKO (1.1 – 7.5 kW)			
Function	Specification		
Rated voltage	3AC 400V-15% ... 480V +10%		
Rated frequency	50/60 Hz		
Output ranges	1.5 kW	2.2 / 3.0 / 4.0 kW	5.5 / 7.5 kW
Housing size	A	B	C
Protective system	IP 55		
EMV approvals acc. to EN61800-3US	C2		
Temperature range	–10 °C ... +50 °C		
Overload capability	1.5 times rated output current		
Protective functions	undervoltage, overvoltage, I <sup>2</sup> t-restriction, short circuit, motor temperature, converter temperature, anti-tilt protection		
Output frequency range	according to layout at factory		
Digital inputs	4		
Fixed frequencies	7		
Digital outputs	2		
Analog inputs	2 analog inputs (0/2 – 10V, 0/4 – 20mA)		
Analog outputs	0..10V (-Imax = 10mA) or 0..20mA (burden R = 500Ω)		
Process control	PID		
Relay outputs	2 x NO contacts 250V AC 2A		
USB interface	USB on plug M12 (RS485/RS232)		
Manual control unit (optional)	MMI with cable		
Bus modules (optional)	Profibus DP, CAN on request		
UL approval	yes		

### Dimensions



Motor power for Brinkmann pump kW	housing size	a mm	b mm	c mm	d mm	k mm
1,1 – 1,7	A	233	153	120	176	221
1,9 – 4,0	B	270	189	133	218	241
5,0 – 7,5	C	307	233	181	258	256





TECHNICAL DATA Series FKS (11 – 55 kW)				
Function	Specification			
Rated voltage	3AC 380V ... 480V ±10% 3Phasen			
Rated frequency	50/60 Hz			
Output ranges	1.5 ...3.0 kW	4.0 ...7.5 kW	11 ...22 kW	30 ...55 kW
Housing size	A	B	C	D
Protective system	IP 55			
Filter class A	integrated			
Temperature range	-10 °C ... +40 °C			
Control procedure	U/f			
Overload capability	1.5 times rated output current			
Protective functions	undervoltage, overvoltage, overload, short circuit, motor failure, rotor lockup, excessive motor temperature, excessive converter temperature			
Output frequency range	according to layout at factory			
Digital inputs	6, 4 of these can be parameterised as required			
Fixed frequencies	4			
Fadable frequency ranges	4			
Relay outputs	2 x NO contacts 250V AC 1A			
Analog inputs	2 analog inputs (0/2 – 10V, 0/4 – 20mA), 1 input for PI controller			
Serial interface	RS 232			
Process control	PI			
Multiple pump configuration	up to 6 pumps			
UL approval	no			

### Dimensions

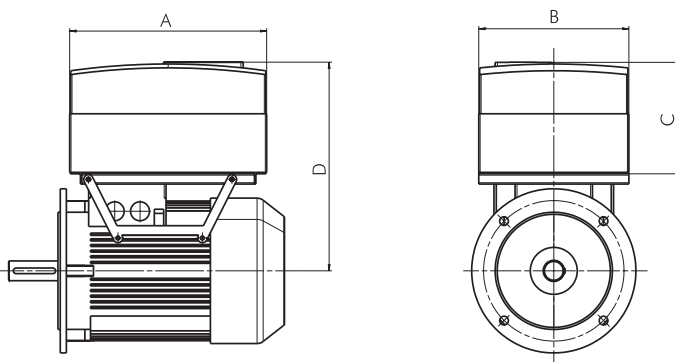

Motor power for Standard pump kW	housing size	A mm	B mm	C mm	D mm
1,5 – 3	A	260	190	158	286
4 – 7,5	B	325	250	170	343
11 – 18,5	C	420	320	235	440
22	C	420	320	235	515
30 – 37	D	600	450	290	610
45	D	600	450	290	635
55	D	600	450	290	667

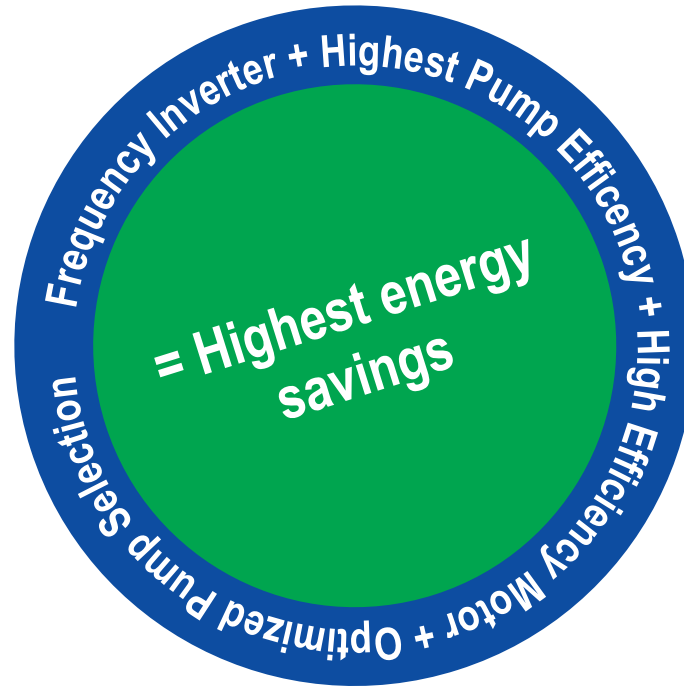

### Energy consumption is influenced by:

**Pump efficiency**

**Motor efficiency**

**Frequency inverter**

**Right pump selection / working point**

**Application / Fluids**

### Energy saving by:

- highest screw spindle pump efficiency
- semi and closed impeller pumps

- high efficiency motors (IE2)

- adjusting of the working point based on various applications

- customer training
- BPtubes – calculation program

- highest pump and curve variety

## DESINA



### DESINA – DEcentral and Standardized INstAllation technology

DESINA includes a complete concept for standardization and decentralization of the electronic and fluid technical installation of machines and systems. The specifications for the required components were defined in cooperation between the machine tool industry, automotive and supplier industry.

DESINA considers proven solutions such as open bus systems, industrial standards for connectors, etc.

By standardizing components, interfaces and connection elements it is possible to achieve highly varying field bus systems on a common physical basis.

### Pin assignment for HAN 10-pin connector for pumps with motors up to 5.5 kW

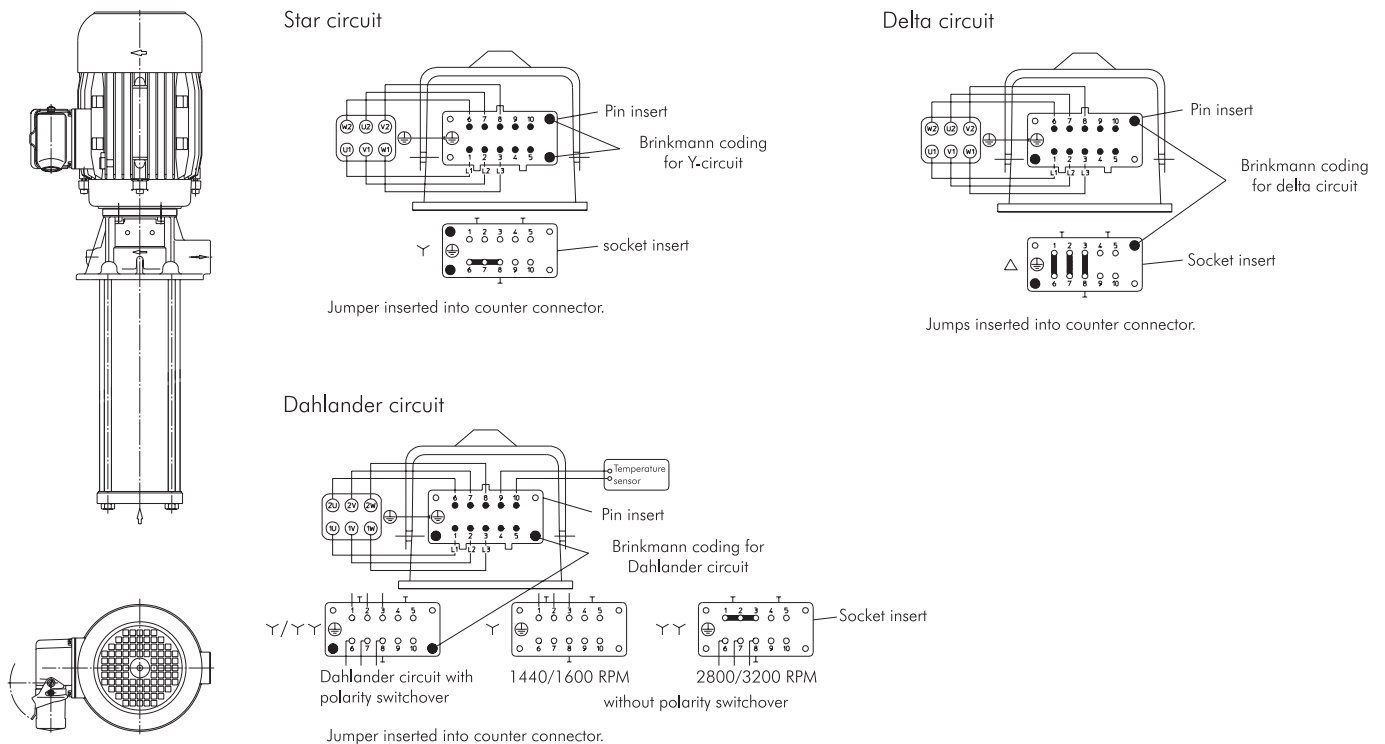

### Assignment for HAN modular plug connector for pumps with motors from 7.5 kW to 10 kW

#### Version with thermistor:

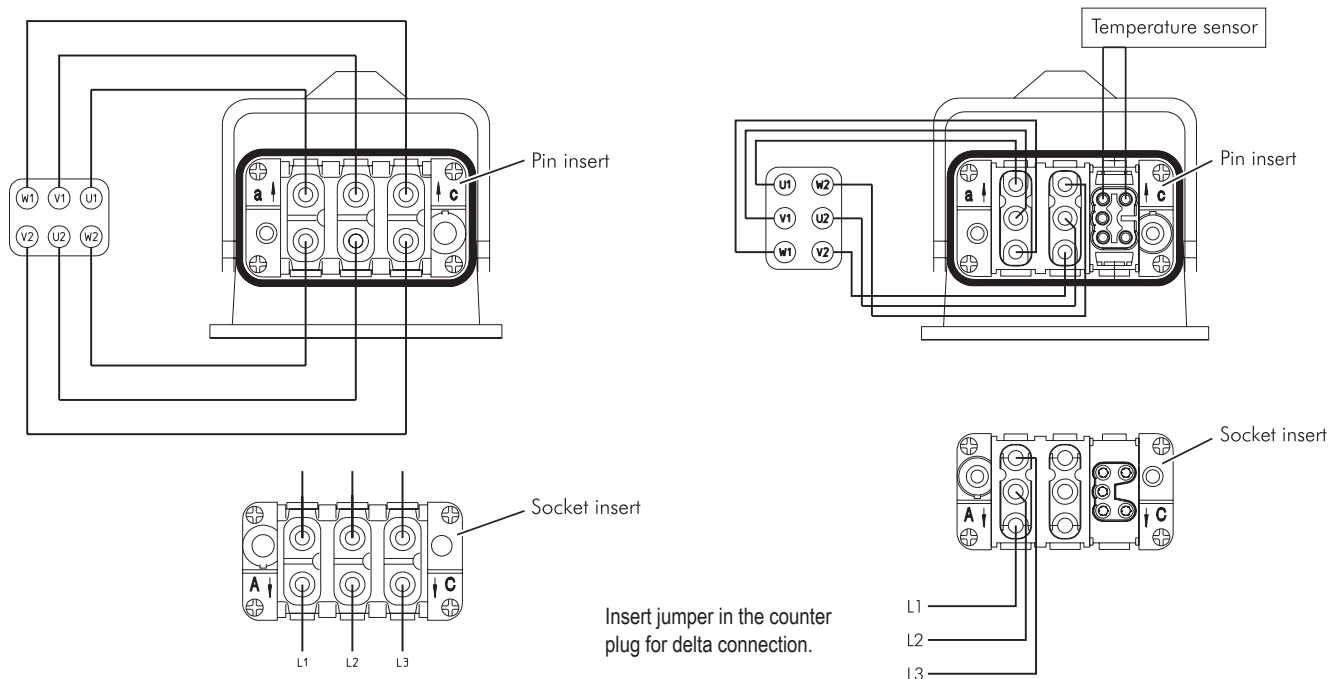



## Lifting pump versions ST...



The comprehensive hydraulic module system ensures optimum adaptation to your specific application requirements.

Depending on whether emulsion or oil is to serve as the coolant during mechanical processing, the features described below can be implemented as selected; if desired even with integrated frequency converter.

The range includes standard lifting pumps such as the STA900 with 10 mm sphere size passage as well as the classic Vortex pumps such as the SFT1100 with a 50 mm sphere size passage and extends all the way to the cutter pump with its integrated cutting mechanism. All pumps are equipped with a 45 degree flange which allows for a either vertical or horizontal pipe connection and which offers a G ¼ port for the connection of a pressure gauge.

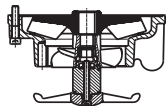

### Lifting pump versions ST...

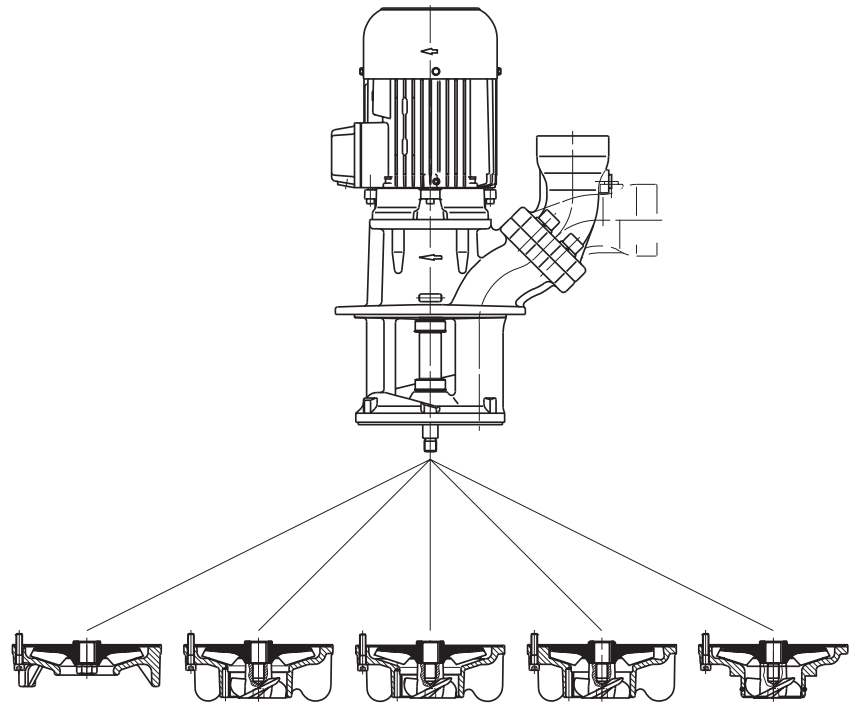

SFL and SGL pumps are also available with an additional agitator at the pump suction. The agitator can either be supplied directly with the pump assembly or is available as a separate component for installation in the field at a later date.

STA	SAL	SFL	SGL	STS
<b>Immersion pumps</b>	<b>Quick suctioning immersion pumps</b>	<b>Quick suctioning immersion pumps</b>	<b>Quick suctioning immersion pumps</b>	<b>Suction immersion pump</b>
Lifting pump for standard applications	Lifting pump for emulsions with some percentage of air	Lifting pump for emulsions/oil with increased percentage of chips	Lifting pump for oil with high percentage of air (fine machining)	Pump for vacuum filter, e.g. on split sieve basis for vacuums from -0.3 ... -0.5 bar
	Quick suctioning feature	Quick suctioning feature	Quick suctioning feature	

### SFL Lifting pump versions

	Impeller material	Inlet cover material	Slurping mode	Chip handling capabilities	Max. chip to coolant ratio by weight	Type	Chip diameter mm	Chip length mm
<b>SFL...Standard</b>	cast steel	special cast iron	yes	coloured metal, aluminium, cast iron	1%	<b>SFL 650</b>	8	15
<b>SFL...CM1</b>	CrMo	special cast iron	yes	steel, medium alloyed steel	1%	<b>SFL 850</b>	10	20
<b>SFL...CM3</b>	CrMo	CrMo	yes	forged materials high alloyed steels hardened steels	1%	<b>SFL1150</b>	15	30
<b>SFL...CM4*)</b>	CrMo	CrMo	yes	forged materials high alloyed steels hardened steels	1%	<b>SFL1350</b>	15	30
						<b>SFL1550</b>	15	30
						<b>SFL1850</b>	15	30
						<b>SFL2350</b>	25	50

\*) additional Chrome Molybdenum insert in circular channel.

All information stated above is only intended as a general guide line for your system layout. Prior to placing your order please consult with our highly skilled sales force regarding your specific application in order to ensure proper pump selection.



### Lifting pump versions SFT/SFT-C

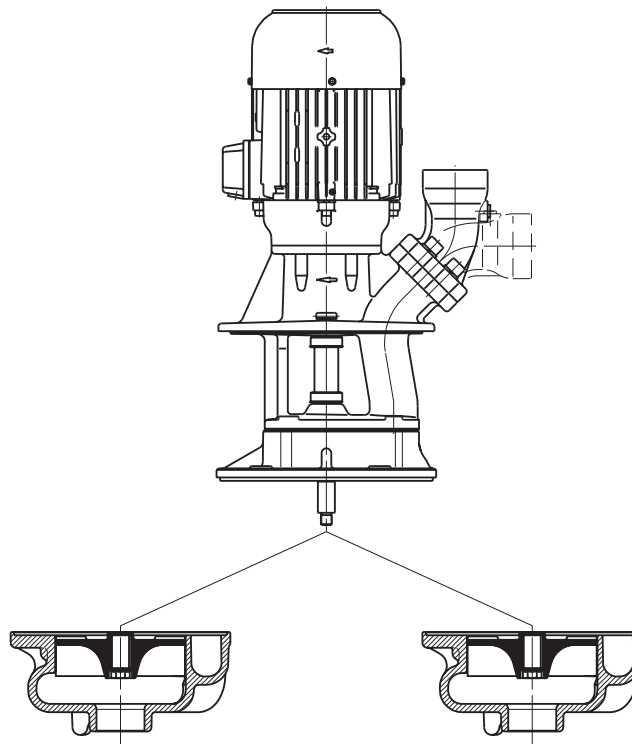

#### SFT

##### Vortex pumps

Lifting pump for emulsion with large chips  
(up to 50 mm sphere size passage)

#### SFT-C

##### Vortex pumps

Lifting pump for emulsion with large chips  
(40 mm sphere size passage),  
without shaft bushing

### SFT Lifting pump versions

	Impeller material	Inlet cover material	Shaft bushing	Max. chip to coolant ratio by weight	sphere size passage	Chip handling capabilities
<b>SFT 450</b>	Cast steel	Special cast iron	SIC/SIC	1,5%	50	coloured metal aluminium cast iron steel alloyed steel hardened steels forged steels
<b>SFT 710</b>	Cast steel	Special cast iron	SIC/SIC	1,5%	50	
<b>SFT1100</b>	Cast steel	Special cast iron	SIC/SIC	1,5%	50	
<b>SFT1300</b>	Cast steel	Special cast iron	Cartridge	1,5%	45	
<b>SFT1350</b>	Cast steel	Special cast iron	Cartridge	1,5%	45	
<b>SFT1400</b>	Cast steel	Special cast iron	Cartridge	1,5%	45	
<b>SFT2254</b>	Cast steel	Special cast iron	Cartridge	1,5%	45	
<b>SFT3054</b>	Cast steel	Special cast iron	Cartridge	1,5%	45	
<b>SFT3554</b>	Cast steel	Special cast iron	Cartridge	1,5%	45	
<b>SFT1554-C</b>	Cast steel	Special cast iron	–	1,5%	40	

All information stated above is only intended as a general guide line for your system layout. Prior to placing your order please consult with our highly skilled sales force regarding your specific application in order to ensure proper pump selection.

## Lifting pump versions SFC



### Cutter Pumps SFC

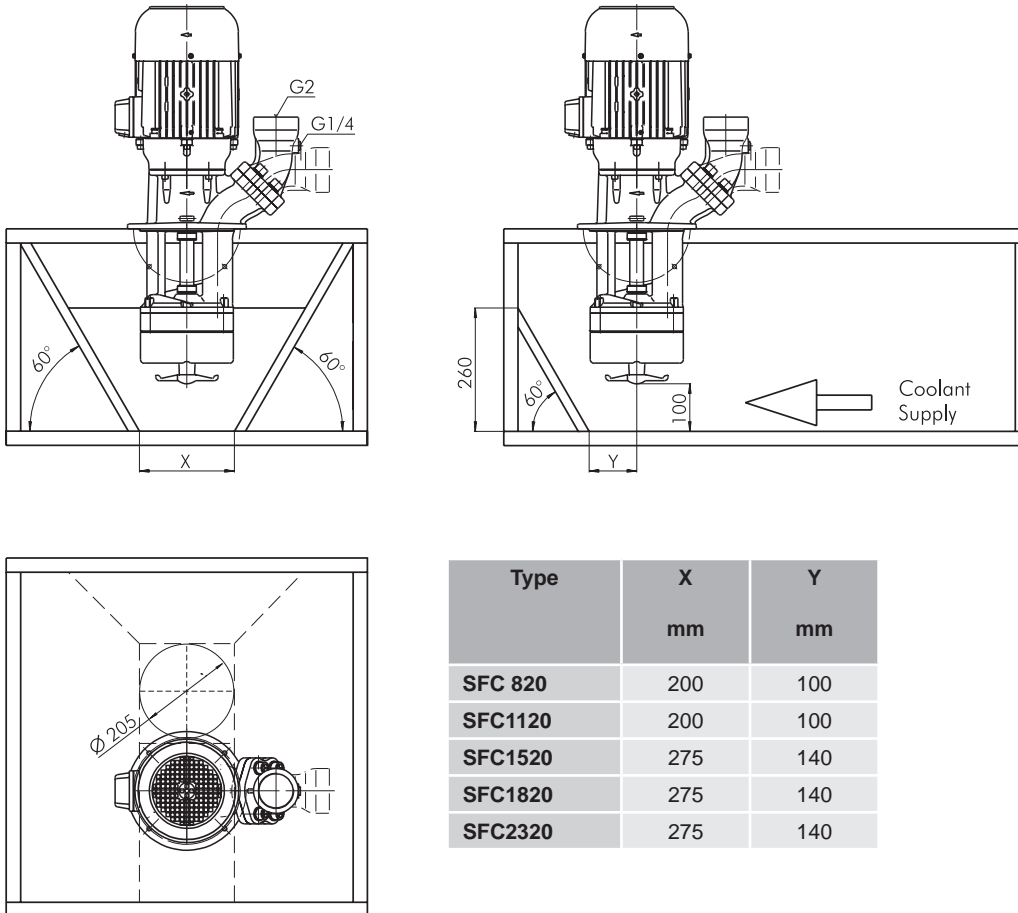

Type	X mm	Y mm
SFC 820	200	100
SFC1120	200	100
SFC1520	275	140
SFC1820	275	140
SFC2320	275	140

The SFC series cutter pumps are capable of cutting aluminum chips and similar materials and pumping of these materials along with the coolant fluid. An agitator located at the pump suction helps to break up and separate any large bundles of chips or birds nests which reach the pump suction.

The hardened cutting unit (>60HRC) is cutting chips and other materials and the above located semi-open impeller allows with its large clearances to pump the particles along with the coolant fluid from the machine back to the filter. The SFC pumps are capable of handling chip to coolant ratios of up to 1.5% by weight.

The cutter pump is equipped with a maintenance free shock absorbing bushing which has outstanding dry running capabilities. Instead of cycling the pumps, the SFC pumps should be run continuously in order to prevent chips from entering the back plane of the impeller.

All information stated above is only intended as a general guide line for your system layout. Prior to placing your order please consult with our highly skilled sales force regarding your specific application in order to ensure proper pump selection.

The minimum distance of 100mm between the bottom of the tank and the agitator must always be maintained in order to prevent unwanted foreign objects, such as broken tool parts, from entering pump and damaging the cutting mechanism. The tank bottom must be checked and any foreign objects must be removed regularly.

The walls of the tank around the pump should be sloped at a 60 degree angle to avoid chips from gathering inside the tank. The coolant supply should be aimed directly at the pump to ensure that also large bundles of chips reach the pump suction (please refer to the above tank design as a guide line for your tank layout).

Pumps of the SFC series have the following unique characteristics:

- Oversized motor to transfer additional cutting forces via the driving shaft if necessary
- Axial impeller which has been optimized for the cutting process
- Adjustable gap between both cutting blades for preventive maintenance (due to stiff motor bearing and shaft design)
- Dry running capability
- Maintenance free and shock absorbing bearing bushing



## SAE / 45 degree flanges



### Brinkmann Pumps with SAE flanges or 45 degree flanges

Most Brinkmann pumps with motors larger than 0.5 kW are equipped with the user friendly SAE flange or 45 degree flange connection which allows for either vertical or horizontal pipe connection. Each SAE flange or 45 degree flange is equipped with an additional G 1/4 pressure gauge connection.

For optimized chip transport and to avoid chip blockages inside the pumps, all flow is directed in long soft turns. All flanges are designed in a way that any cross section changes down stream are always increasing never decreasing in order to prevent bottle necks inside the pump.

#### Small pump body (Ø 140 mm)

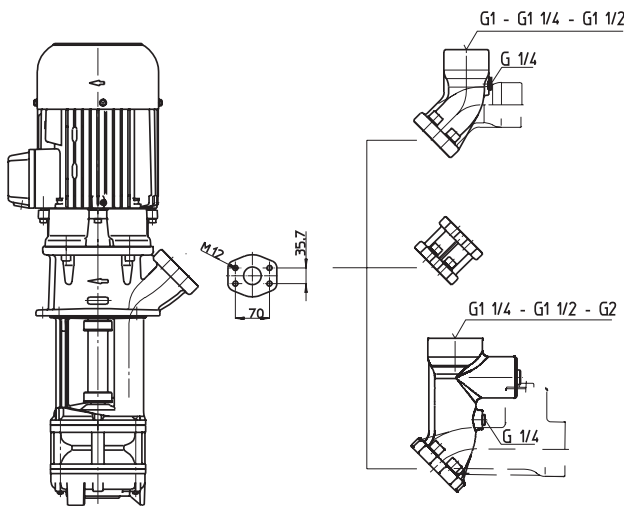

#### SAE flange G1, G1¼, G1½, G2

Standard as shown on data sheets. Fully interchangeable. Upon request also available for TC and TH pumps.

#### SAE Extension Port

This extension port is available upon request for all pumps which are featuring an SAE flange.

#### Regulating Valve for SAE flange G1, G1¼, G1½, G2

This regulation valve allows to adjust the flow rate of the pump even during regular operation. This valve has no complete shut off function. An additional check valve is available upon request.

#### Large pump body (≥ Ø 200 mm)

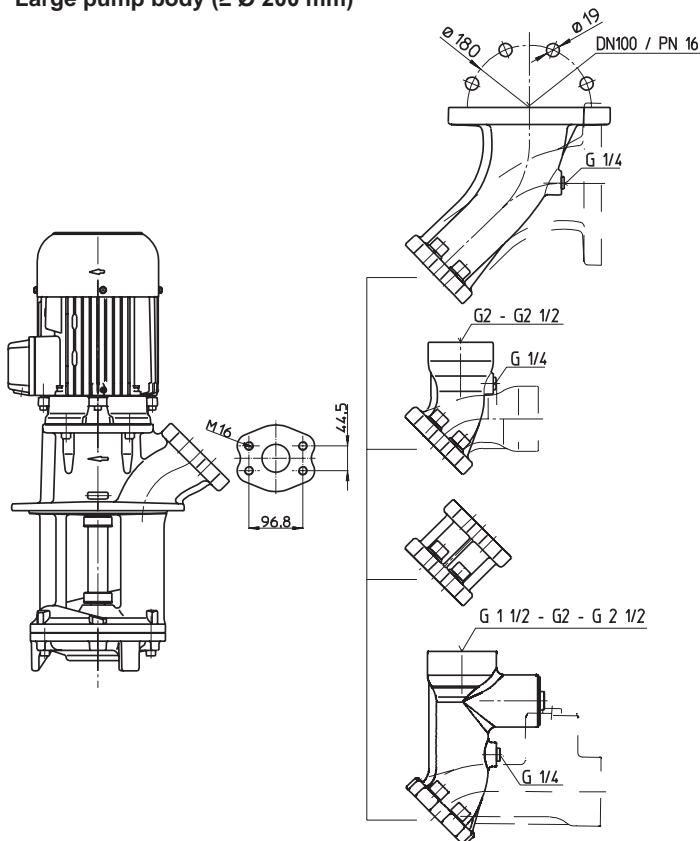

#### Flange DN100/PN16

This flange is available upon request for all pumps which are featuring a 45 degree flange.

#### 45 degree flange G2, G2½

Standard as shown on data sheets. G 2 is available upon request instead of G 2 ½ without surcharge.

#### Extension Port for 45 degree flange

This extension port is available upon request for all pumps which are featuring a 45 degree flange.

#### Regulating Valve for 45 degree flange G1½, G2, G2½

This regulation valve allows to adjust the flow rate of the pump even during regular operation. This valve has no complete shut off function. An additional check valve is available upon request.

# Immersion Pumps

## TB16...100

### Semi-open impellers

#### TB16, 25, 40 TB63, 100

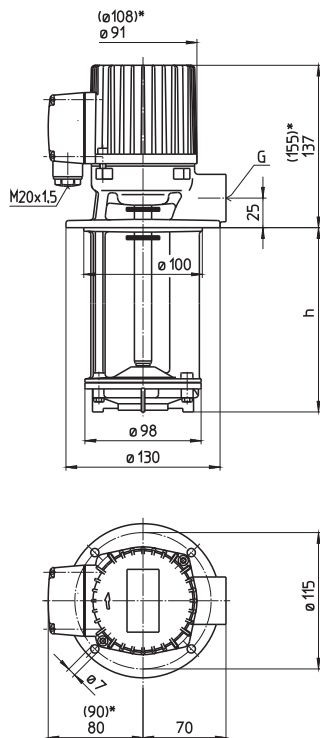

\*) Dimensions for TB63, TB100

Type	Vol. del. at manom. del. head l/min / m	Depth of immersion h mm	Pipe connection G	Weight kg	Power kW	Voltage 3~ V	Fre- quency Hz	Rated current A	Speed 1/min
<b>TB16/90</b>	16/2	90	G ½	4.1	0.07	220-240	50	0.35	2800
<b>120</b>		115		4.3		380-420	50	0.20	2800
<b>170</b>		165		4.6		460	60	0.20	3300
<b>220</b>		215		4.9					
<b>TB25/90</b>	30/2	90	G ½	4.2	0.1	220-240	50	0.38	2700
<b>120</b>		115		4.4		380-420	50	0.22	2700
<b>170</b>		165		4.6		460	60	0.22	3200
<b>220</b>		215		5.0					
<b>270</b>		265	G ¾	5.5					
<b>350</b>		345		6.1					
<b>TB40/90</b>	50/2	95	G ¾	4.3	0.12	220-240	50	0.44	2700
<b>120</b>		120		4.5		380-420	50	0.25	2700
<b>170</b>		170		4.7		460	60	0.25	3200
<b>220</b>		220		5.1					
<b>270</b>		270		5.6					
<b>350</b>		350		6.2					
<b>TB63/90</b>	75/2	105	G ¾	4.8	0.21	220-240	50	0.71	2800
<b>120</b>		130		5.1		380-420	50	0.41	2800
<b>170</b>		180		5.5		460	60	0.41	3300
<b>220</b>		230		5.8					
<b>270</b>		280		6.1					
<b>350</b>		360		6.9					
<b>TB100/120</b>	100/2	130	G ¾	5.2	0.24	220-240	50	0.76	2750
<b>170</b>		180		5.6		380-420	50	0.44	2750
<b>220</b>		230		5.9		460	60	0.44	3250
<b>270</b>		280		6.2					
<b>350</b>		360		7.0					

### Immersion Pumps

are plain centrifugal pumps with the impeller fitted on the driving shaft extension. They are mounted on top of the container, the pump extension being immersed in the coolant.

The dimensions are based on standard specification **EN 12157**.

The maximum coolant level must stay a few mm/inches below the mounting flange.

### Applications

Types of fluid  
 coolants  
 cooling/cutting oils  
 other fluids on request

Kinematic viscosity  
 ...90 mm<sup>2</sup>/s (90 cSt)

Pumping temperature  
 0...60° C

### Construction

Pump body	cast iron
Cover	POM
Impeller	POM
Shaft	steel
Optional: Cover	cast iron cast iron with thread
Impeller	brass cast iron

Optional:  
 These models are also available with **single phase motor**.

Noise level TB16...TB100	45 dBA
-----------------------------	--------

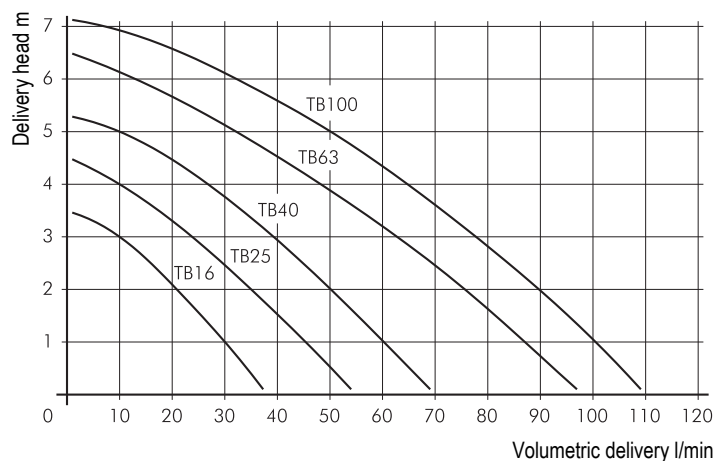

# Immersion Pumps

## TA160...600

Semi-open impellers

### TA160, 250, 400 TA600

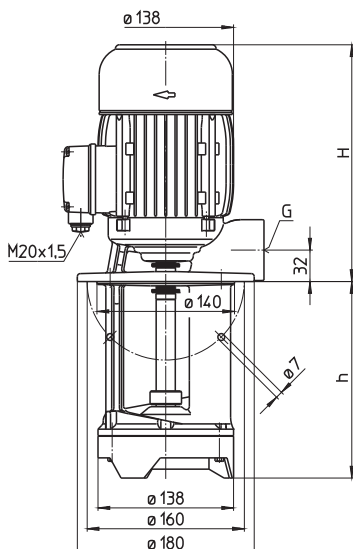

Type	Vol. del. at manom. del. head l/min / m	Height H mm	Depth of im- mersion h mm	Pipe connec- tion G	Weight kg	Power kW	Voltage 3 ~ V	Fre- quency Hz	Rated current A	Speed 1/min
<b>TA160/200</b>	220/2	223	200	G 1 ¼	11.5	0.5	220-240	50	2.42	2800
<b>270</b>			270		12.5					
<b>350</b>			350		13.5					
<b>440</b>			440		14.5					
<b>550</b>			550		15.5					
<b>TA250/200</b>	280/2	223	200	G 1 ¼	12	0.63	220-240	50	2.6	2750
<b>270</b>			270		13					
<b>350</b>			350		14					
<b>440</b>			440		15					
<b>550</b>			550		16					
<b>TA400/200</b>	380/2	241	200	G 1 ½	14	0.85	220-240	50	4.3	2800
<b>270</b>			270		15					
<b>350</b>			350		16					
<b>440</b>			440		17					
<b>550</b>			550		18					
<b>TA600/210</b>	500/2	241	210	G 1 ½	15	0.92	220-240	50	4.7	2700
<b>280</b>			280		16					
<b>360</b>			360		17					
<b>450</b>			450		18					
<b>560</b>			560		19					

### Immersion Pumps

are plain centrifugal pumps with the impeller fitted on the driving shaft extension. They are mounted on top of the container, the pump extension being immersed in the coolant.

The dimensions are based on standard specification **EN 12157**.

The maximum coolant level must stay a few mm/inches below the mounting flange.

### Applications

Types of fluid  
coolants  
cooling/cutting oils

Kinematic viscosity  
...90 mm<sup>2</sup>/s (90 cSt)

Pumping temperature  
0...60° C  
higher temperatures upon request

### Construction

Pump body	cast iron
Cover	POM
	cast iron (TA600)
Impeller	POM
	brass (TA600)
Shaft	steel
Optional:	
Cover	cast iron (TA160...TA400)
Suction cover	with threaded inlet
Impeller	brass (TA160...TA400) cast steel (TA160...TA600)

### Noise level

TA160...TA250	60 dBA
TA400...TA600	62 dBA

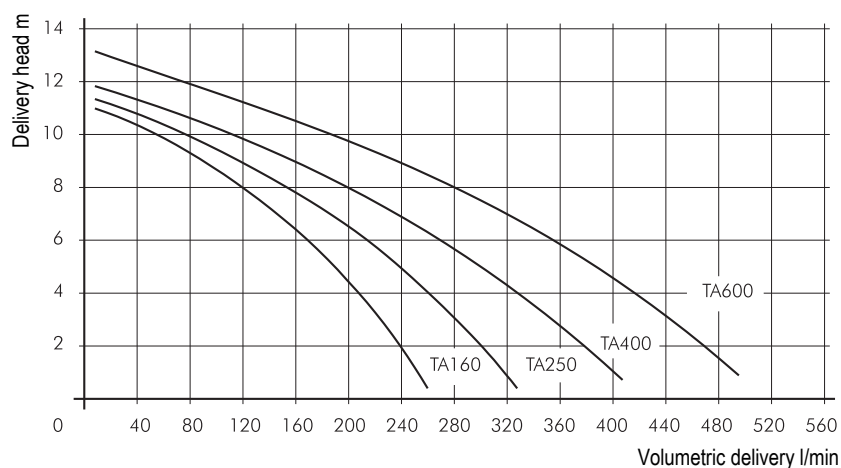

# Immersion Pumps

## TE/STE141...146

### Semi-open impellers

#### TE141, 142

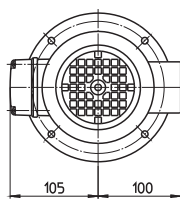
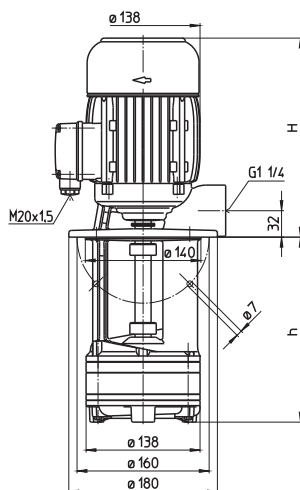

#### STE141...146

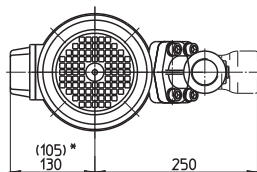
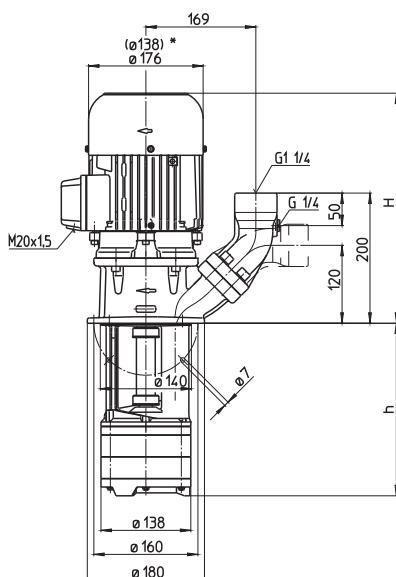

\*) Dimensions for STE141, 142

Type	Vol. del. at manom. del. head l/min / m	Height H mm	Depth of immersion h mm	Weight kg	Power kW	Voltage 3 ~ V	Fre- quency Hz	Rated current A	Speed 1/min
<b>TE141/200</b>	80/11	223	200	12.5	0.5	220-240	50	2.42	2800
<b>270</b>			270	13.5					
<b>350</b>			350	14.5					
<b>440</b>			440	15.5					
<b>550</b>			550	17.5					
<b>TE142/150</b>	80/20	261	150	15	1.1	220-240	50	5.0	2700
<b>230</b>			230	16					
<b>300</b>			300	17					
<b>380</b>			380	18					
<b>470</b>			470	19					
<b>580</b>			580	21					
<b>STE141/120</b>	80/11	293	120	14	0.54	220-240	50	2.42	2800
<b>200</b>			200	15					
<b>270</b>			270	16					
<b>350</b>			350	17					
<b>440</b>			440	18					
<b>550</b>			550	19					
<b>STE142/150</b>	80/20	331	150	18	1.1	220-240	50	5.0	2700
<b>230</b>			230	19					
<b>300</b>			300	20					
<b>380</b>			380	21					
<b>470</b>			470	22					
<b>580</b>			580	23					
<b>STE143/190</b>	80/33	355	185	28	1.5	220-240	50	6.6	2850
<b>270</b>			265	29					
<b>340</b>			335	30					
<b>420</b>			415	31					
<b>510</b>			505	32					
<b>620</b>			615	33					
<b>STE144/220</b>	80/45	355	220	29	1.7	220-240	50	7.1	2850
<b>300</b>			300	30					
<b>370</b>			370	31					
<b>450</b>			450	32					
<b>540</b>			540	33					
<b>650</b>			650	34					
<b>STE145/270</b>	80/56	395	270	34	2.2	220-240	50	9.2	2850
<b>350</b>			350	35					
<b>420</b>			420	36					
<b>500</b>			500	37					
<b>590</b>			590	38					
<b>700</b>			700	39					
<b>STE146/300</b>	80/70	405	305	34	2.6	220-240	50	10.9	2850
<b>380</b>			385	35					
<b>450</b>			455	36					
<b>530</b>			535	37					
						220-240	50	6.3	2850



### Immersion Pumps

are plain centrifugal pumps with the impeller fitted on the driving shaft extension. They are mounted on top of the container, the pump extension being immersed in the coolant.

The dimensions are based on standard specification **EN 12157**.

The maximum coolant level must stay a few mm/inches below the mounting flange.

The STE serie offers a **(SAE) flange** with pressure gauge connection port.

The flange can be rotated for either horizontal or vertical pipe connections.



All types are also available as quick-suctioning immersion pumps equipped with **"BRINKMANN's Suction De-aeration System"**. See series TL/STL.

### Applications

Types of fluid  
coolants  
cooling/cutting oils  
Kinematic viscosity  
...90 mm<sup>2</sup>/s (90 cSt)  
Pumping temperature  
0...60° C

### Construction

Pump body	cast iron
Cover	cast iron PPS (TE141, STE141)
Impellers	PPS
Shaft	steel
Optional: Cover	cast iron (TE141, STE141)
Suction cover	with threaded inlet
Impellers	brass cast steel
Other materials	on request

Noise level  
TE141...STE142 60 dBA  
STE143...STE146 68 dBA

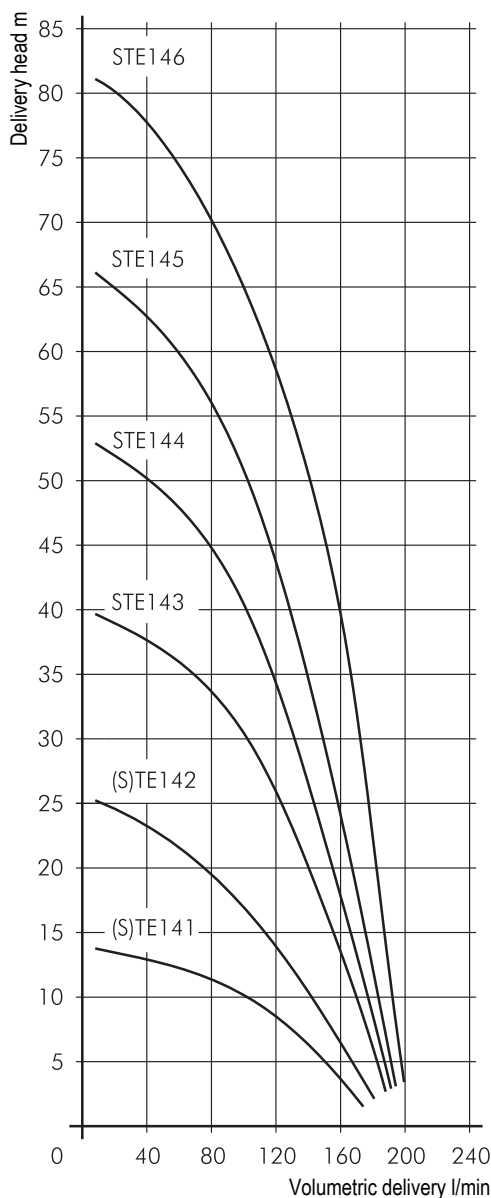

# Immersion Pumps

## TA/STA301...306

### Semi-open impellers

#### TA302

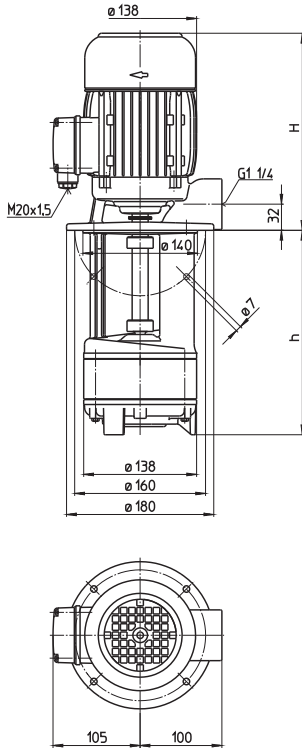

#### STA301...306

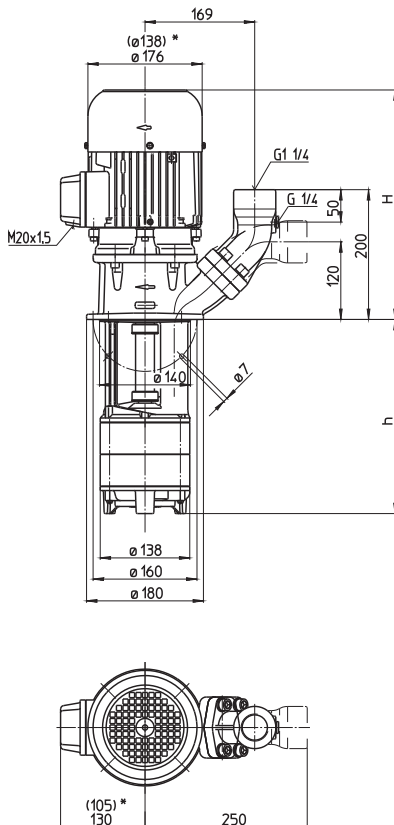

\*) Dimensions for STA301, 302

Type	Vol. del. at manom. del. head l/min /m	Height H mm	Depth of immersion h mm	Weight kg	Power kW	Voltage 3 ~ V	Fre- quency Hz	Rated current A	Speed 1/min
<b>TA302/170</b>	160/12	261	170	16.5	1.1	220-240	50	5.0	2700
<b>250</b>			250	17.5		380-420	50	2.9	2700
<b>320</b>			320	18.5		460	60	2.9	3300
<b>400</b>			400	19.5					
<b>490</b>			490	20.5					
<b>600</b>			600	21.5					
<b>STA301/120</b>	160/7	293	120	13	0.54	220-240	50	2.42	2800
<b>200</b>			200	14		380-420	50	1.40	2800
<b>270</b>			270	15		460	60	1.40	3300
<b>350</b>			350	16					
<b>440</b>			440	17					
<b>550</b>			550	18					
<b>STA302/170</b>	160/12	331	170	20	1.1	220-240	50	5.0	2700
<b>250</b>			250	21		380-420	50	2.9	2700
<b>320</b>			320	22		460	60	2.9	3300
<b>400</b>			400	23					
<b>490</b>			490	24					
<b>600</b>			600	25					
<b>STA303/220</b>	160/18	355	220	33	1.5	220-240	50	6.6	2850
<b>300</b>			300	34		380-420	50	3.8	2850
<b>370</b>			370	35		460	60	3.8	3400
<b>450</b>			450	36					
<b>540</b>			540	37					
<b>650</b>			650	38					
<b>850</b>			850	40					
<b>1000</b>			1000	41					
<b>STA304/270</b>	160/24	395	270	40	1.9	220-240	50	8.5	2850
<b>350</b>			350	41		380-420	50	4.9	2850
<b>420</b>			420	42		460	60	4.9	3400
<b>500</b>			500	43					
<b>590</b>			590	44					
<b>700</b>			700	45					
<b>900</b>			900	47					
<b>1050</b>			1050	48					
<b>STA305/320</b>	160/29	395	320	43	2.2	220-240	50	9.2	2850
<b>400</b>			400	44		380-420	50	5.3	2850
<b>470</b>			470	45		460	60	5.3	3400
<b>550</b>			550	46					
<b>640</b>			640	47					
<b>750</b>			750	48					
<b>950</b>			950	50					
<b>1100</b>			1100	51					
<b>STA306/370</b>	160/37	405	370	48	2.6	220-240	50	10.9	2850
<b>450</b>			450	49		380-420	50	6.3	2850
<b>520</b>			520	50		460	60	6.3	3400
<b>600</b>			600	51					
<b>690</b>			690	53					
<b>800</b>			800	54					
<b>1000</b>			1000	55					

### Immersion Pumps

are plain centrifugal pumps with the impeller fitted on the driving shaft extension. They are mounted on top of the container, the pump extension being immersed in the coolant.

The maximum coolant level must stay a few mm/inches below the mounting flange.

The STA serie offers a **(SAE) flange** with pressure gauge connection port.

The flange can be rotated for either horizontal or vertical pipe connections.

 All types are also available as quick-suctioning immersion pumps equipped with **"BRINKMANN's Suction De-aeration System"**. See series TAL/SAL.

 All types are also available as suction immersion pump with a connection to the vacuum filters on the suction side. See series STS.

### Applications

Types of fluid  
coolants  
cooling/cutting oils  
Kinematic viscosity  
...90 mm<sup>2</sup>/s (90 cSt)  
Pumping temperature  
0...80° C  
0...60° C (TA302)  
higher temperatures upon request

### Construction

Pump body	cast iron
Cover	cast iron
Impellers	POM (TA302) brass POM (TA302) steel
Shaft	
Optional:	
Suction cover	with threaded inlet
Impeller	cast steel
Other materials	on request

Noise level	
TA302...STA302	60 dBA
STA303...STA306	66 dBA

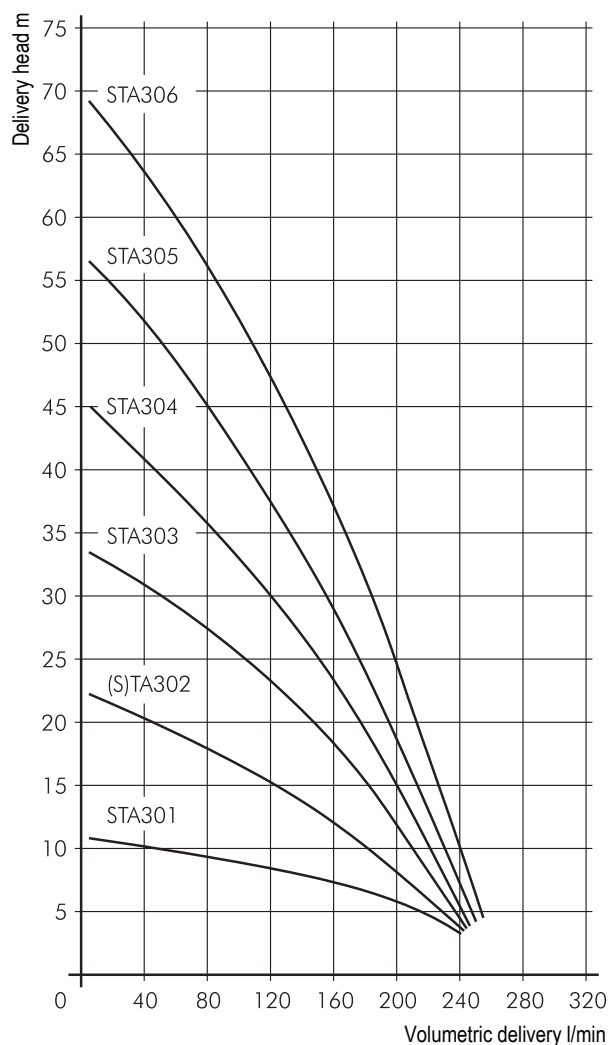

# Immersion Pumps

## STA401...409

### Semi-open impellers

#### STA401...409

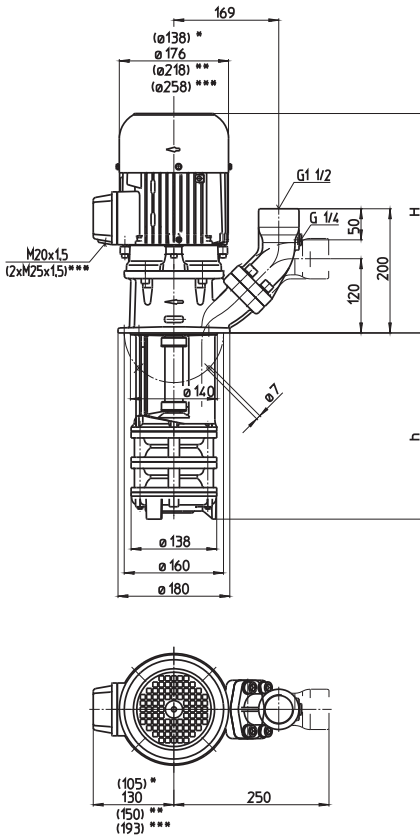

- \*) Dimensions for STA401
- \*\*\*) Dimensions for STA406, 407
- \*\*\*\*) Dimensions for STA409

Type	Vol. del. at manom. del. head l/min /m	Height H mm	Depth of immersion h mm	Weight kg	Power kW	Voltage 3 ~ V	Fre- quency Hz	Rated current A	Speed 1/min
<b>STA401/120</b>	250/5	311	120	15	0.85	220-240 380-420 460	50 50 60	4.3 2.5 2.5	2800 2800 3300
<b>200</b>			200	16					
<b>270</b>			270	17					
<b>350</b>			350	18					
<b>440</b>			440	19					
<b>550</b>			550	20					
<b>750</b>			750	22					
<b>900</b>			900	23					
<b>STA402/170</b>	250/12	355	170	30	1.3	220-240 380-420 460	50 50 60	5.2 3.0 3.0	2850 2850 3400
<b>250</b>			250	31					
<b>320</b>			320	32					
<b>400</b>			400	33					
<b>490</b>			490	34					
<b>600</b>			600	35					
<b>800</b>			800	37					
<b>950</b>			950	38					
<b>STA403/220</b>	250/20	355	220	32	1.7	220-240 380-420 460	50 50 60	7.1 4.1 4.1	2850 2850 3400
<b>300</b>			300	33					
<b>370</b>			370	34					
<b>450</b>			450	35					
<b>540</b>			540	36					
<b>650</b>			650	37					
<b>850</b>			850	39					
<b>1000</b>			1000	40					
<b>STA404/270</b>	250/27	395	270	38	2.2	220-240 380-420 460	50 50 60	9.2 5.3 5.3	2850 2850 3400
<b>350</b>			350	39					
<b>420</b>			420	40					
<b>500</b>			500	41					
<b>590</b>			590	42					
<b>700</b>			700	43					
<b>900</b>			900	45					
<b>1050</b>			1050	46					
<b>STA405/320</b>	250/33	405	320	42	2.6	220-240 380-420 460	50 50 60	10.9 6.3 6.3	2850 2850 3400
<b>400</b>			400	43					
<b>470</b>			470	44					
<b>550</b>			550	45					
<b>640</b>			640	46					
<b>750</b>			750	47					
<b>950</b>			950	49					
<b>1100</b>			1100	50					
<b>STA406/370</b>	250/39	445	370	55	3.3	220-240 380-420 460	50 50 60	13.8 8.0 8.0	2900 2900 3450
<b>450</b>			450	56					
<b>520</b>			520	57					
<b>600</b>			600	58					
<b>690</b>			690	59					
<b>800</b>			800	60					
<b>1000</b>			1000	61					
<b>STA407/420</b>	250/45	445	420	59	4.0	220-240 380-420 460	50 50 60	16.5 9.5 9.5	2900 2900 3450
<b>500</b>			500	60					
<b>570</b>			570	61					
<b>650</b>			650	62					
<b>740</b>			740	63					
<b>850</b>			850	64					
<b>STA409/520</b>	250/52	480	520	80	5.5	220-240 380-420 460	50 50 60	22.0 12.5 12.5	2900 2900 3450
<b>600</b>			600	81					
<b>670</b>			670	82					
<b>750</b>			750	83					
<b>840</b>			840	84					
<b>950</b>			950	85					

### Immersion Pumps

are plain centrifugal pumps with the impeller fitted on the driving shaft extension. They are mounted on top of the container, the pump extension being immersed in the coolant.

The maximum coolant level must stay a few mm/inches below the mounting flange.

The STA serie offers a **(SAE) flange** with pressure gauge connection port.

The flange can be rotated for either horizontal or vertical pipe connections.



All types are also available as quick-suctioning immersion pumps equipped with **"BRINKMANN's Suction De-aeration System"**. See series SAL.



All types are also available as suction immersion pump with a connection to the vacuum filters on the suction side. See series STS.



### Applications

Types of fluid  
coolants  
cooling/cutting oils  
Kinematic viscosity  
...90 mm<sup>2</sup>/s (90 cSt)  
Pumping temperature  
0...80° C  
higher temperatures upon request

### Construction

Pump body	cast iron
Cover	cast iron
Impellers	brass
Shaft	steel
Optional: Suction cover Impellers	with threaded inlet cast steel
Noise level	
STA401	62 dBA
STA402...STA405	66 dBA
STA406...STA409	71 dBA

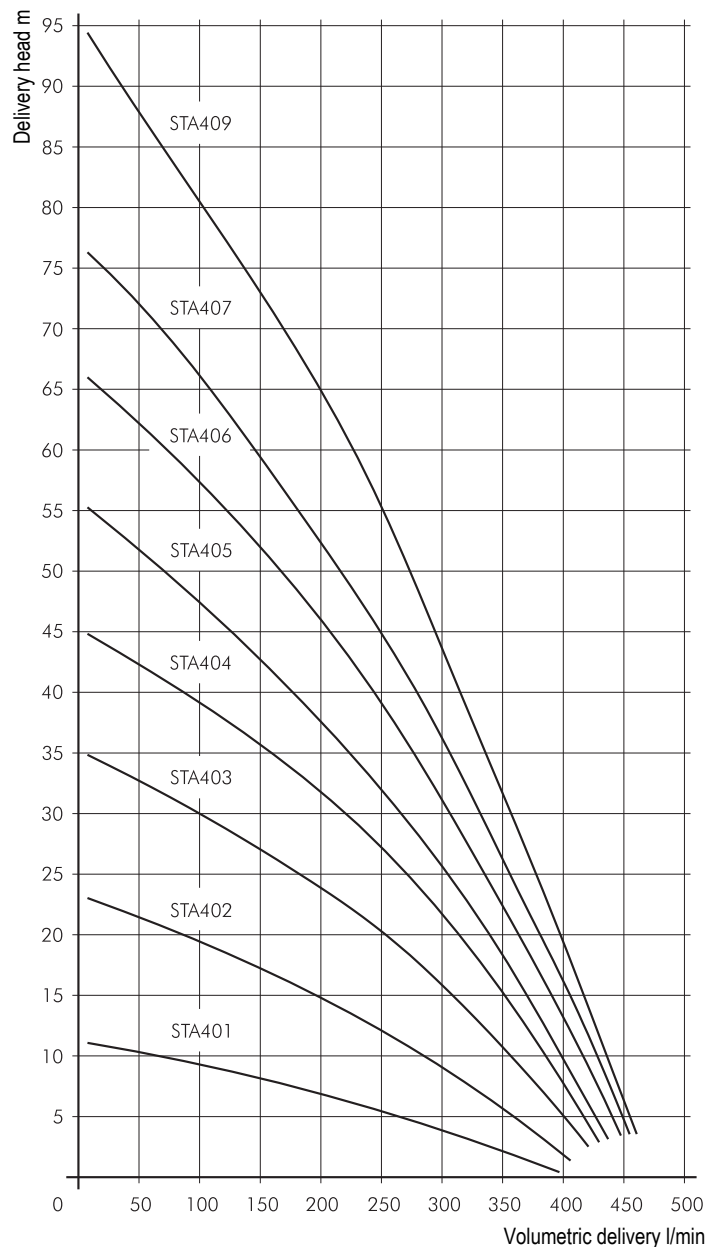

# Immersion Pumps

## STA601...609

### Semi-open impellers

#### STA601...609

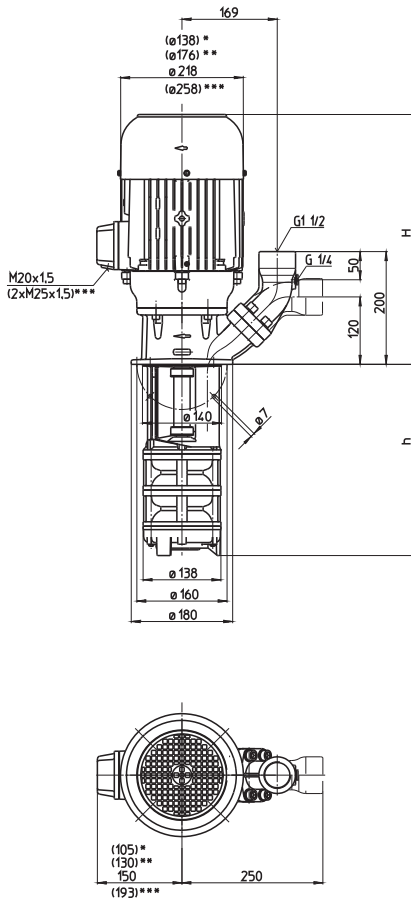

\*) Dimensions for STA601  
 \*\*) Dimensions for STA602  
 \*\*\*) Dimensions for STA605, 607, 609

Type	Vol. del. at manom. del. head l/min / m	Height H mm	Depth of immersion h mm	Weight kg	Power kW	Voltage 3 ~ V	Fre- quency Hz	Rated current A	Speed 1/min
<b>STA601/130</b>	400/4	311	130	16	0.92	220-240	50	4.7	2700
<b>210</b>			210	17					
<b>280</b>			280	18					
<b>360</b>			360	19					
<b>450</b>			450	20					
<b>560</b>			560	21					
<b>760</b>			760	25	2.2	220-240	50	9.2	2850
<b>910</b>			910	26					
<b>STA602/200</b>	400/11	395	195	34					
<b>280</b>			275	35					
<b>350</b>			345	36					
<b>430</b>			425	37					
<b>520</b>			515	38	3.3	220-240	50	13.8	2900
<b>630</b>			625	40					
<b>830</b>			825	42					
<b>980</b>			975	43					
<b>STA603/260</b>	400/17	445	260	49					
<b>340</b>			340	50					
<b>410</b>			410	51					
<b>490</b>			490	52					
<b>580</b>			580	53	4.0	220-240	50	16.5	2900
<b>690</b>			690	54					
<b>890</b>			890	56					
<b>1040</b>			1040	57					
<b>STA604/330</b>	400/23	445	325	54					
<b>410</b>			405	55					
<b>480</b>			475	56					
<b>560</b>			555	57					
<b>650</b>			645	58	5.5	220-240	50	22.0	2900
<b>760</b>			755	59					
<b>960</b>			955	61					
<b>1110</b>			1105	62					
<b>STA605/390</b>	400/32	480	390	72					
<b>470</b>			470	73					
<b>540</b>			540	74					
<b>620</b>			620	75					
<b>710</b>			710	76	7.5	220-240	50	29	2900
<b>820</b>			820	77					
<b>1020</b>			1020	78					
<b>STA607/520</b>	400/45	520	520	90					
<b>600</b>			600	91					
<b>670</b>			670	92					
<b>750</b>			750	93					
<b>840</b>			840	94	10.0	220-240	50	40	2900
<b>950</b>			950	95					
<b>STA609/650</b>	400/62	570	650	109					
<b>730</b>			730	110					
<b>800</b>			800	111					
<b>880</b>			880	112					
<b>980</b>			980	113					
<b>1080</b>			1080	114					



### Immersion Pumps

are plain centrifugal pumps with the impeller fitted on the driving shaft extension. They are mounted on top of the container, the pump extension being immersed in the coolant.

The maximum coolant level must stay a few mm/inches below the mounting flange.

The STA serie offers a **(SAE) flange** with pressure gauge connection port.

The flange can be rotated for either horizontal or vertical pipe connections.



All types are also available as quick-suctioning immersion pumps equipped with **"BRINKMANN's Suction De-aeration System"**. See series SAL.



All types are also available as suction immersion pump with a connection to the vacuum filters on the suction side. See series STS.



### Applications

Types of fluid  
coolants  
cooling/cutting oils  
Kinematic viscosity  
...90 mm<sup>2</sup>/s (90 cSt)  
Pumping temperature  
0...80° C  
higher temperatures upon request

### Construction

Pump body	cast iron
Cover	cast iron
Impellers	brass
Shaft	steel
Optional:	
Suction cover	with threaded inlet
Impellers	cast steel
Noise level	
STA601	62 dBA
STA602	66 dBA
STA603...STA605	71 dBA
STA607...STA609	74 dBA

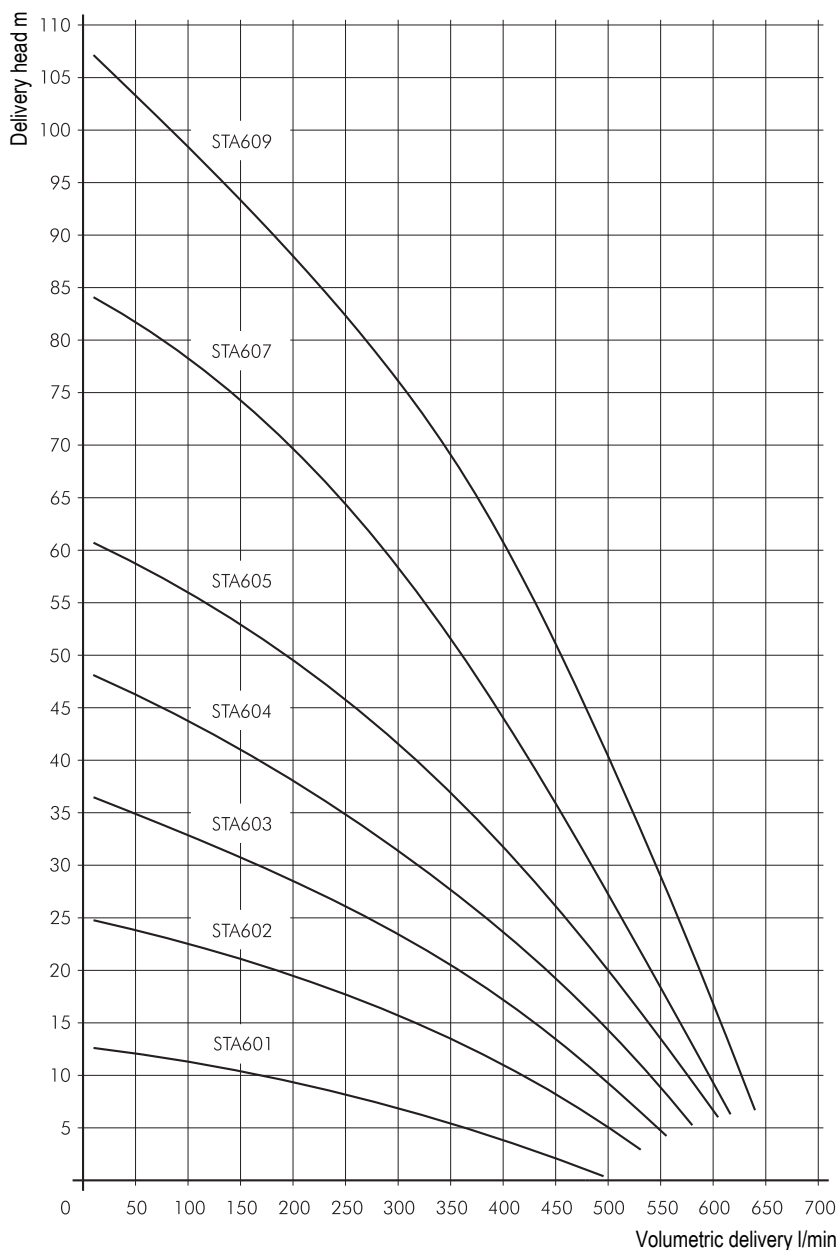

# Immersion Pumps

## STA901...904

### Semi-open impellers

#### STA901, 902 STA903, 904

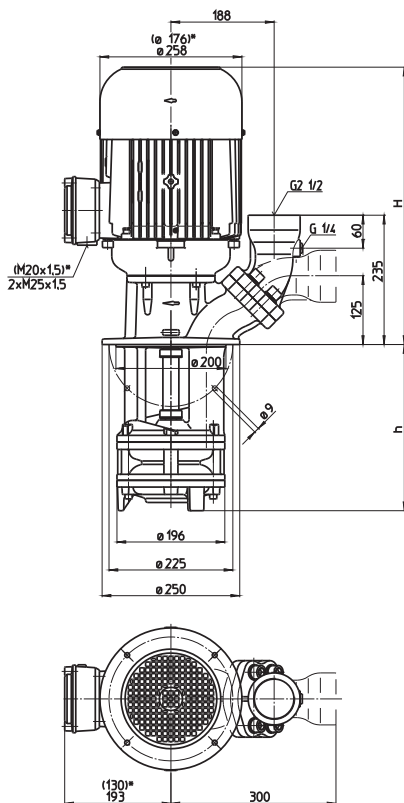

\*) Dimensions for STA901

Type	Vol. del. at manom. del. head l/min /m	Height H mm	Depth of immersion h mm	Weight kg	Power kW	Voltage 3 ~ V	Fre- quency Hz	Rated current A	Speed 1/min
<b>STA901/200</b>	600/12	429	200	49	2.6	220-240	50	10.9	2850
<b>300</b>			300	51					
<b>430</b>			430	53					
<b>550</b>			550	56					
<b>750</b>			750	61					
<b>980</b>			980	68					
<b>1100</b>			1100	72					
<b>STA902/270</b>	600/24	504	270	82	5.5	220-240	50	22.0	2900
<b>370</b>			370	85					
<b>500</b>			500	89					
<b>620</b>			620	93					
<b>820</b>			820	98					
<b>1050</b>			1050	105					
<b>1170</b>			1170	113					
<b>STA903/340</b>	600/38	542	340	102	7.5	220-240	50	29	2900
<b>440</b>			440	105					
<b>570</b>			570	109					
<b>690</b>			690	113					
<b>890</b>			890	118					
<b>1120</b>			1120	125					
<b>STA904/410</b>	600/55	592	410	121	10.0	220-240	50	40	2900
<b>510</b>			510	124					
<b>640</b>			640	128					
<b>760</b>			760	132					
<b>960</b>			960	137					
<b>1190</b>			1190	142					
						460	60	23	3450

### Immersion Pumps

are plain centrifugal pumps with the impeller fitted on the driving shaft extension. They are mounted on top of the container, the pump extension being immersed in the coolant.

The maximum coolant level must stay a few mm/inches below the mounting flange.

The STA serie offers a **flange** with pressure gauge connection port.

The flange can be rotated for either horizontal or vertical pipe connections.



All types are also available as quick-suctioning immersion pumps equipped with "**BRINKMANN's Suction De-aeration System**". See series SAL.

### Applications

Types of fluid  
coolants  
cooling/cutting oils  
Kinematic viscosity  
...90 mm<sup>2</sup>/s (90 cSt)  
Pumping temperature  
0...80° C  
higher temperatures upon request

### Construction

Pump body	cast iron
Cover	cast iron
Impellers	cast steel
Shaft	steel
Optional:	
Suction cover	with threaded inlet
Other materials	on request
Noise level	
STA901	66 dBA
STA902	71 dBA
STA903...STA904	74 dBA

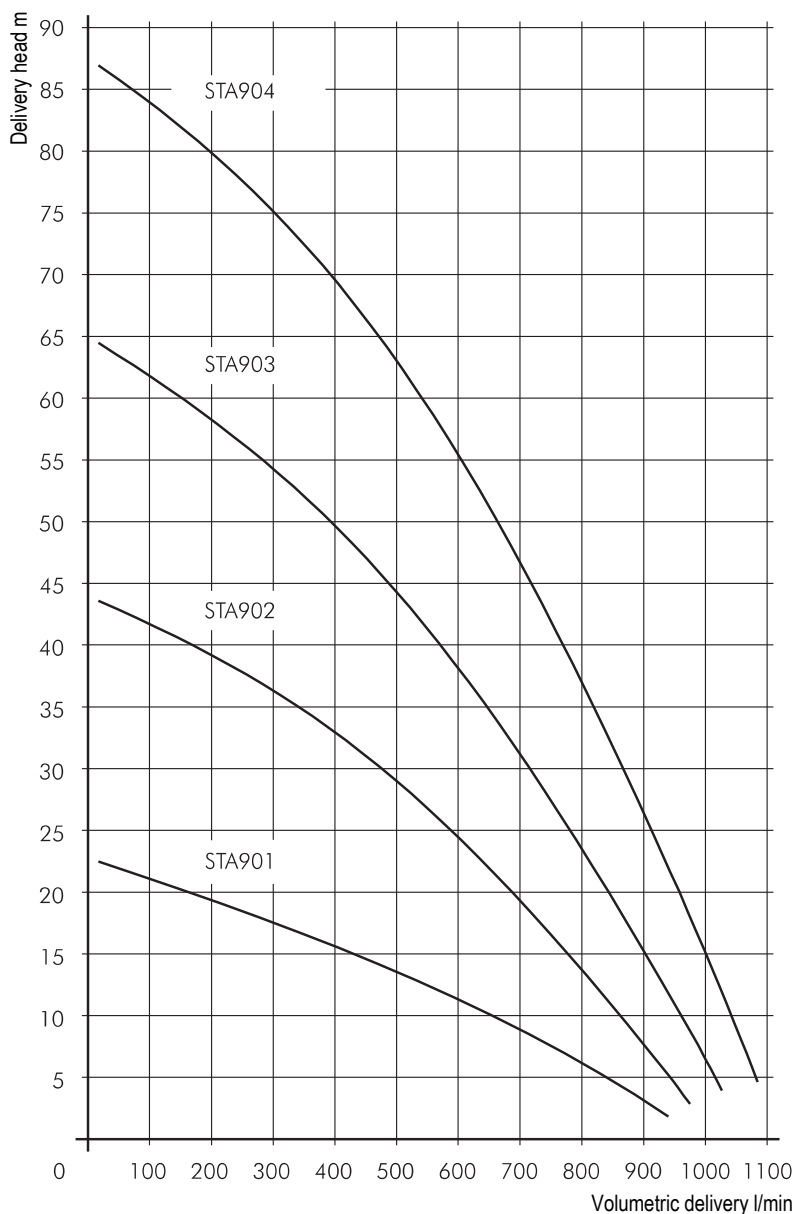

# Immersion Pumps

## STA1001...1006

### Semi-open impellers

#### STA1001...1004

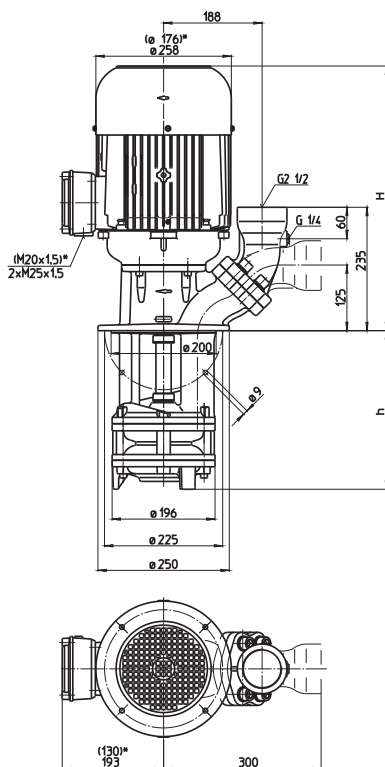

#### STA1006

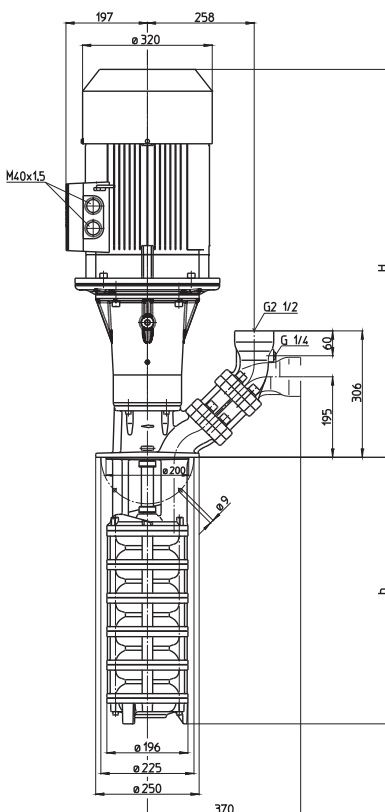

\*) Dimensions for STA1001

Type	Vol. del. at manom. del. head l/min /m	Height H mm	Depth of immersion h mm	Weight kg	Power kW	Voltage 3~ V	Fre- quency Hz	Rated current A	Speed 1/min
<b>STA1001/210</b>	600/15	429	210	50	2.6	220-240	50	10.9	2850
<b>310</b>			310	52		380-420	50	6.3	2850
<b>440</b>			440	54		460	60	6.3	3400
<b>560</b>			560	57					
<b>760</b>			760	62					
<b>990</b>			990	69					
<b>1110</b>			1110	73					
<b>STA1002/290</b>	600/26	504	290	83	5.5	220-240	50	22.0	2900
<b>390</b>			390	86		380-420	50	12.5	2900
<b>520</b>			520	90		460	60	12.5	3450
<b>640</b>			640	94					
<b>840</b>			840	99					
<b>1070</b>			1070	106					
<b>1190</b>			1190	111					
<b>STA1003/370</b>	600/40	542	370	103	7.5	220-240	50	29	2900
<b>470</b>			470	106		380-420	50	17	2900
<b>600</b>			600	110		460	60	17	3450
<b>720</b>			720	114					
<b>920</b>			920	119					
<b>1150</b>			1150	126					
<b>STA1004/450</b>	600/57	592	450	127	10.0	220-240	50	40	2900
<b>550</b>			550	130		380-420	50	23	2900
<b>680</b>			680	134		460	60	23	3450
<b>800</b>			800	138					
<b>1000</b>			1000	143					
<b>1230</b>			1230	150					
<b>STA1006/610</b>	600/86	938	610	168	18.5	400	50	32	2940
<b>710</b>			710	171					
<b>840</b>			840	175	21.3	460	60	31.5	3540
<b>960</b>			960	179					

### Immersion Pumps

are plain centrifugal pumps with the impeller fitted on the driving shaft extension. They are mounted on top of the container, the pump extension being immersed in the coolant.

The maximum coolant level must stay a few mm/inches below the mounting flange.

The STA serie offers a **flange** with pressure gauge connection port.

The flange can be rotated for either horizontal or vertical pipe connections.



All types are also available as quick-suctioning immersion pumps equipped with "**BRINKMANN's Suction De-aeration System**". See series SAL.



All types are also available as suction immersion pump with a connection to the vacuum filters on the suction side. See series STS.



### Applications

Types of fluid  
coolants  
cooling/cutting oils  
Kinematic viscosity  
...90 mm<sup>2</sup>/s (90 cSt)  
Pumping temperature  
0...80° C  
higher temperatures upon request

### Construction

Pump body	cast iron
Cover	cast iron
Impellers	cast steel
Shaft	steel
Optional:	
Suction cover	with threaded inlet
Other materials	on request
Noise level	
STA1001	63 dBA
STA1002	71 dBA
STA1003...STA1004	74 dBA
STA1006	78 dBA

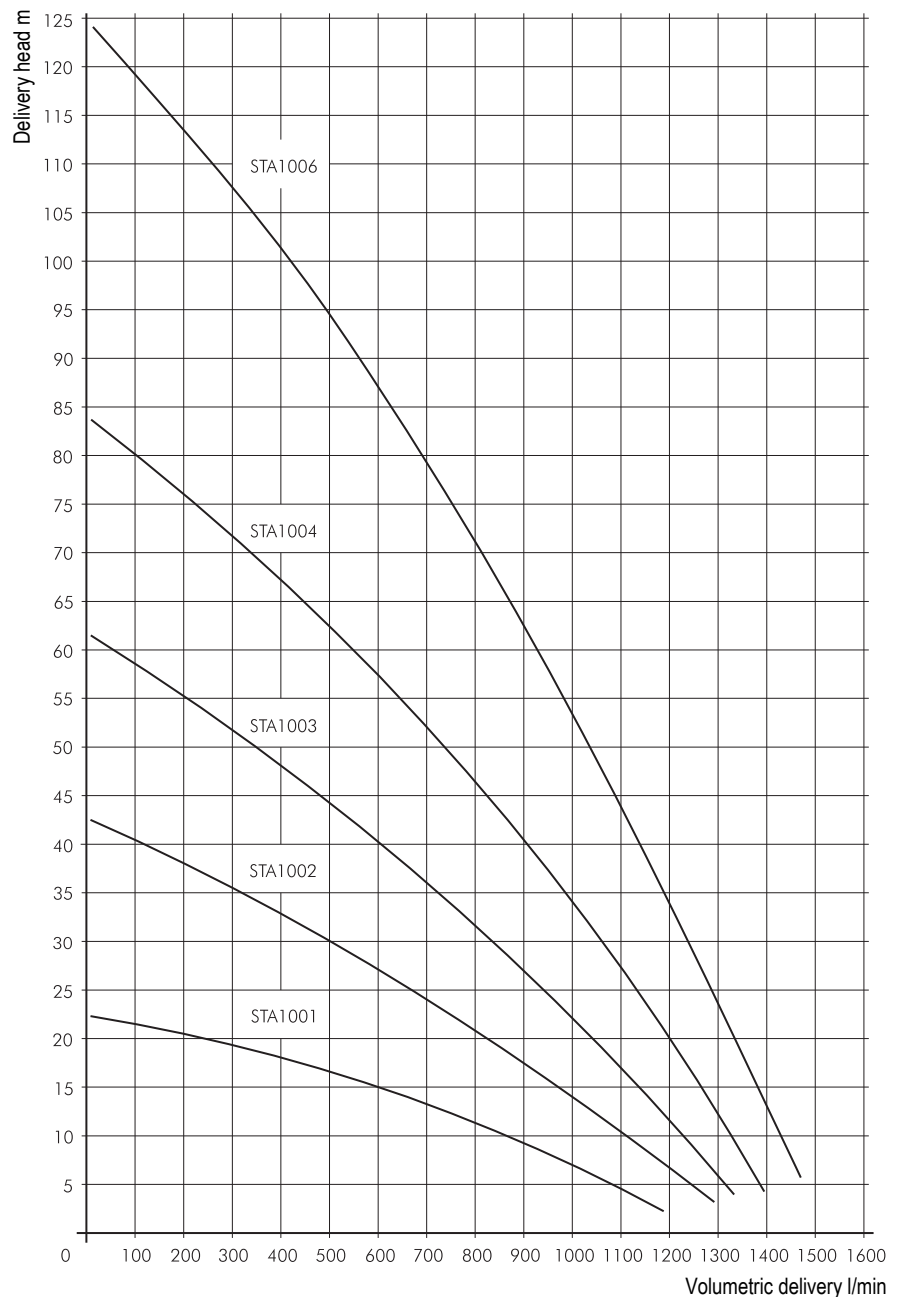

# Immersion Pumps

## STA1301...1303

Semi-open impellers

### STA1301, 1302 STA1303

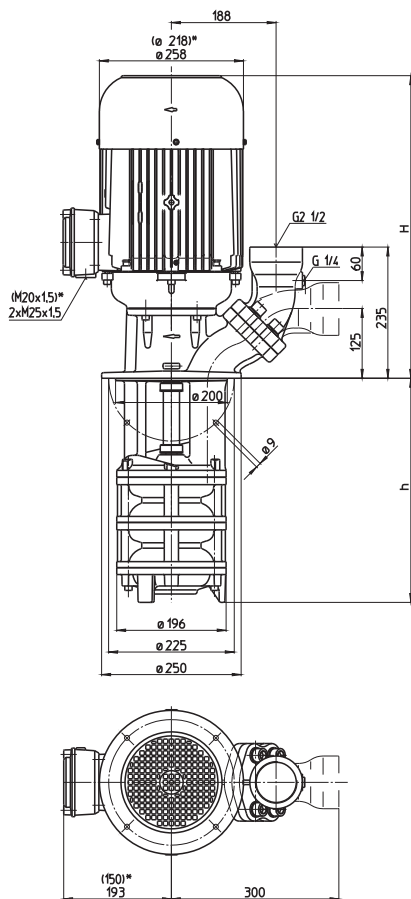

\*) Dimensions for STA1301

Type	Vol. del. at manom. del. head l/min / m	Height H mm	Depth of immersion h mm	Weight kg	Power kW	Voltage 3 ~ V	Fre- quency Hz	Rated current A	Speed 1/min
<b>STA1301/210</b>	900/13	468	210	57	4.0	220-240	50	16.5	2900
<b>310</b>			310	59					
<b>440</b>			440	61					
<b>560</b>			560	64					
<b>760</b>			760	69					
<b>990</b>			990	76					
<b>1110</b>			1110	79					
<b>STA1302/290</b>	900/28	542	290	95	7.5	220-240	50	29	2900
<b>390</b>			390	98					
<b>520</b>			520	102					
<b>640</b>			640	106					
<b>840</b>			840	111					
<b>1070</b>			1070	118					
<b>STA1303/370</b>	900/42	592	370	115	10.0	220-240	50	40	2900
<b>470</b>			470	118					
<b>600</b>			600	124					
<b>720</b>			720	126					
<b>920</b>			920	131					
<b>1150</b>			1150	138					
						380-420	50	17	2900
						460	60	17	3450
							60	23	2900
							60	23	3450



### Immersion Pumps

are plain centrifugal pumps with the impeller fitted on the driving shaft extension. They are mounted on top of the container, the pump extension being immersed in the coolant.

The maximum coolant level must stay a few mm/inches below the mounting flange.

The STA serie offers a **flange** with pressure gauge connection port.

The flange can be rotated for either horizontal or vertical pipe connections.



All types are also available as quick-suctioning immersion pumps equipped with "**BRINKMANN's Suction De-aeration System**". See series SAL.

### Applications

Types of fluid  
coolants  
cooling/cutting oils  
Kinematic viscosity  
...90 mm<sup>2</sup>/s (90 cSt)  
Pumping temperature  
0...80° C  
higher temperatures upon request

### Construction

Pump body	cast iron
Cover	cast iron
Impellers	cast steel
Shaft	steel
Optional:	
Suction cover	with threaded inlet
Other materials	on request
Noise level	
STA1301	71 dBA
STA1302...STA1303	74 dBA

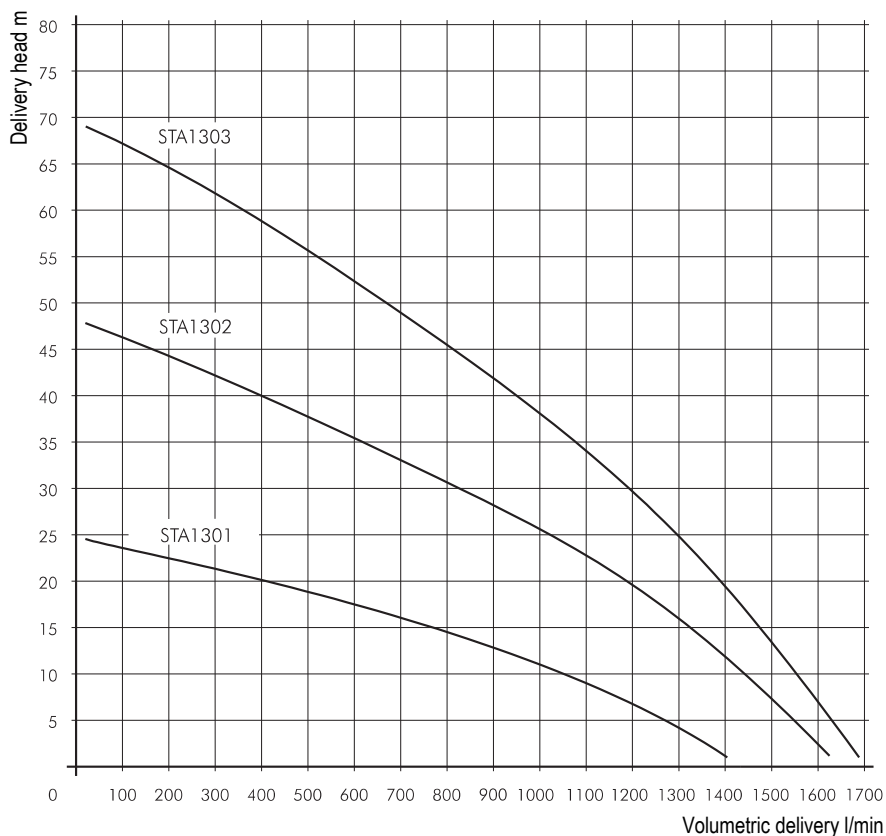

# Immersion Pumps

## STA1600...2500

Semi-open impellers

### STA1600, 2000

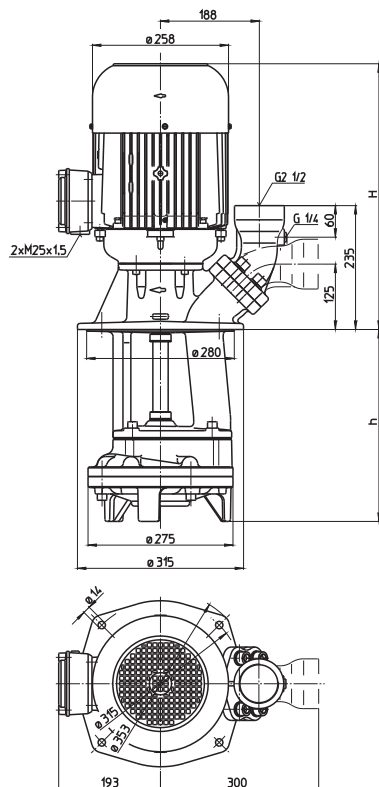

### STA1602...2500

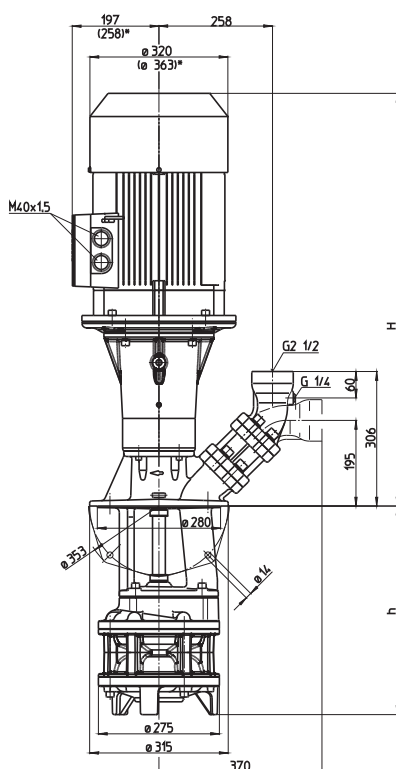

\*) Dimensions for STA2002

Type	Vol. del. at manom. del. head l/min /m	Height H mm	Depth of immersion h mm	Weight kg	Power kW	Voltage 3~ V	Fre- quency Hz	Rated current A	Speed 1/min
<b>STA1600/300</b>	1300/15	542	300	100	7.5	220-240	50	29	2900
<b>430</b>			430	102		380-420	50	17	2900
<b>550</b>			550	104		460	60	17	3450
<b>800</b>			800	110					
<b>1050</b>			1050	112					
<b>STA2000/300</b>	1600/15	592	300	119	10.0	220-240	50	40	2900
<b>430</b>			430	121		380-420	50	23	2900
<b>550</b>			550	124		460	60	23	3450
<b>800</b>			800	130					
<b>1050</b>			1050	132					
<b>STA1602/410</b>	1300/37	938	410	178	18.5	400	50	32	2940
<b>540</b>			540	180					
<b>660</b>			660	182					
<b>910</b>			910	188	21.3	460	60	31.5	3540
<b>1160</b>			1160	190					
<b>STA2002/410</b>	1600/47	1022	410	241	22.0	400	50	39	2945
<b>540</b>			540	245					
<b>660</b>			660	249					
<b>910</b>			910	258	24.5	460	60	37	3545
<b>1160</b>			1160	262					
<b>STA2500/330</b>	2200/20	938	330	147	18.5	400	50	32	2940
<b>460</b>			460	149					
<b>580</b>			580	151					
<b>830</b>			830	167	21.3	460	60	31.5	3540
<b>1080</b>			1080	169					

### Immersion Pumps

are plain centrifugal pumps with the impeller fitted on the driving shaft extension. They are mounted on top of the container, the pump extension being immersed in the coolant.

The maximum coolant level must stay a few mm/inches below the mounting flange.

The STA serie offers a **flange** with pressure gauge connection port.

The flange can be rotated for either horizontal or vertical pipe connections.



All types are also available as quick-suctioning immersion pumps equipped with "**BRINKMANN's Suction De-aeration System**". See series SAL.

### Applications

Types of fluid  
coolants  
cooling/cutting oils  
Kinematic viscosity  
...90 mm<sup>2</sup>/s (90 cSt)  
Pumping temperature  
0...80° C

### Construction

Pump body	cast iron
Cover	cast iron
Impeller	cast steel
Shaft	steel
Other materials	on request

Noise level	
STA1600...STA2000	74 dBA
STA1602...STA2500	78 dBA

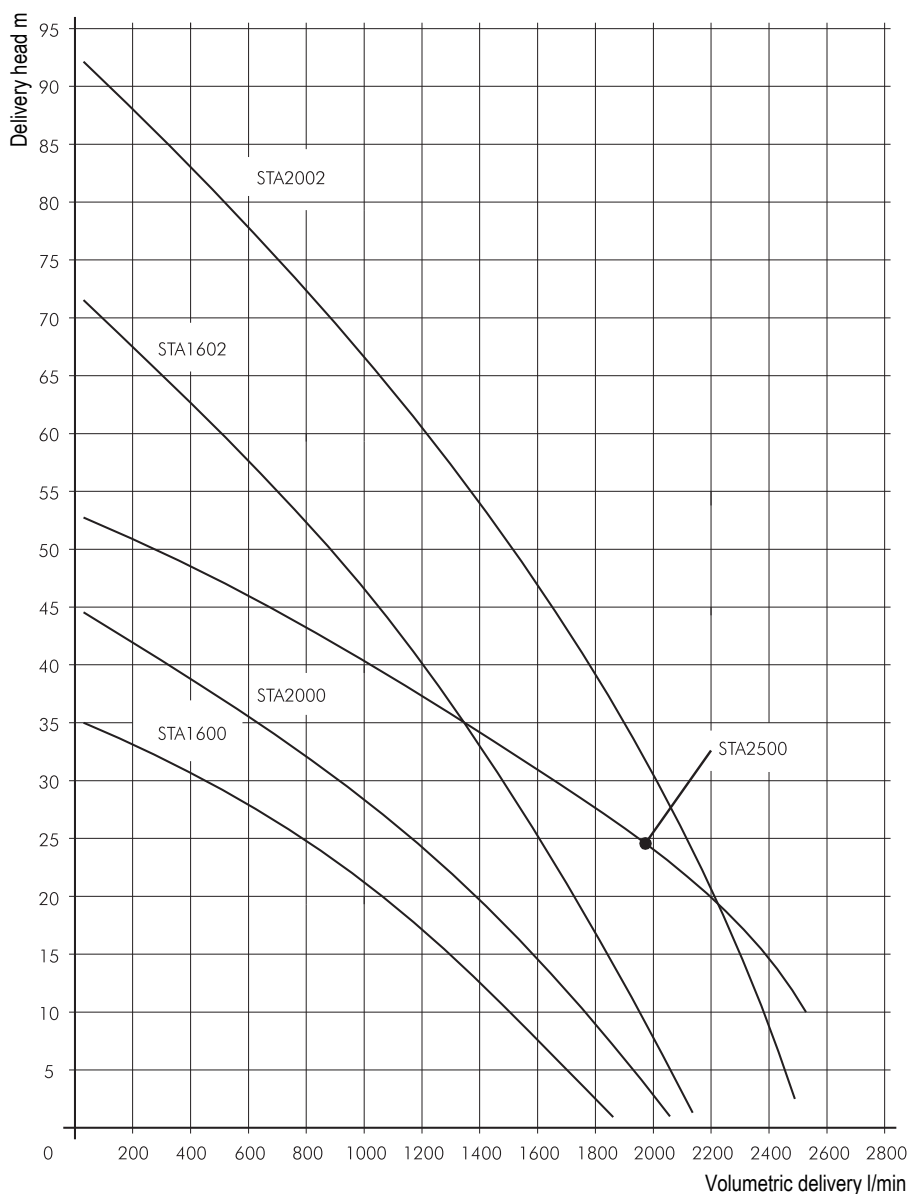

# Immersion Pumps

## STA3600...4500

Semi-open impellers

### STA3600, 4500

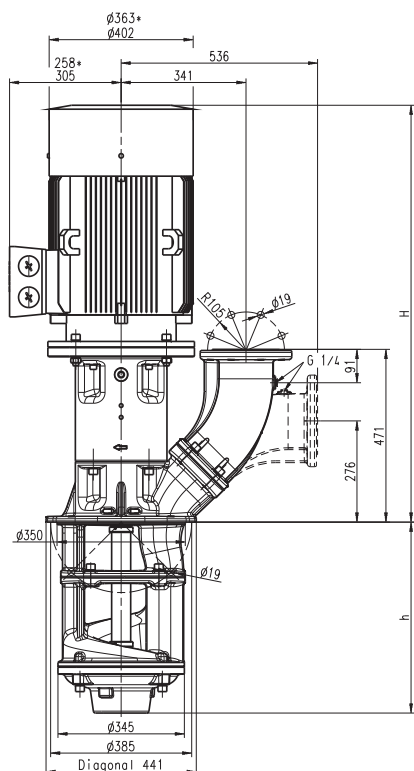

\*) Dimensions for STA3600

Type	Vol. del. at manom. del. head l/min /m	Height H mm	Depth of im- mersion h mm	Weight kg	Power kW	Voltage 3 ~ V	Fre- quency Hz	Rated current A	Speed 1/min
<b>STA3600/520</b>	3500/20	1085	521	323	22.0	400	50	39	2945
<b>720</b>			721	338					
<b>920</b>			921	353	24.5	460	60	37	3545
<b>1270</b>			1271	418					
<b>2020</b>			2021	493					
<b>2220</b>			2221	508					
<b>STA4500/520</b>	4500/30	1138	521	403	37.0	400	50	65	2950
<b>720</b>			721	418					
<b>920</b>			921	433	41.5	460	60	62	3550
<b>1270</b>			1271	498					
<b>2020</b>			2021	573					
<b>2220</b>			2221	588					

### Immersion Pumps

are plain centrifugal pumps with the impeller fitted on the driving shaft extension. They are mounted on top of the container, the pump extension being immersed in the coolant.

The maximum coolant level must stay a few mm/inches below the mounting flange.

The STA serie offers a **flange** with pressure gauge connection port.

The flange can be rotated for either horizontal or vertical pipe connections.

### Applications

Types of fluid  
coolants  
cooling/cutting oils  
Kinematic viscosity  
...90 mm<sup>2</sup>/s (90 cSt)  
Pumping temperature  
0...80° C

### Construction

Pump body	cast iron
Cover	cast iron
Impeller	cast steel
Shaft	steel
Other materials	on request

Noise level	
STA3600	82 dBA
STA4500	84 dBA

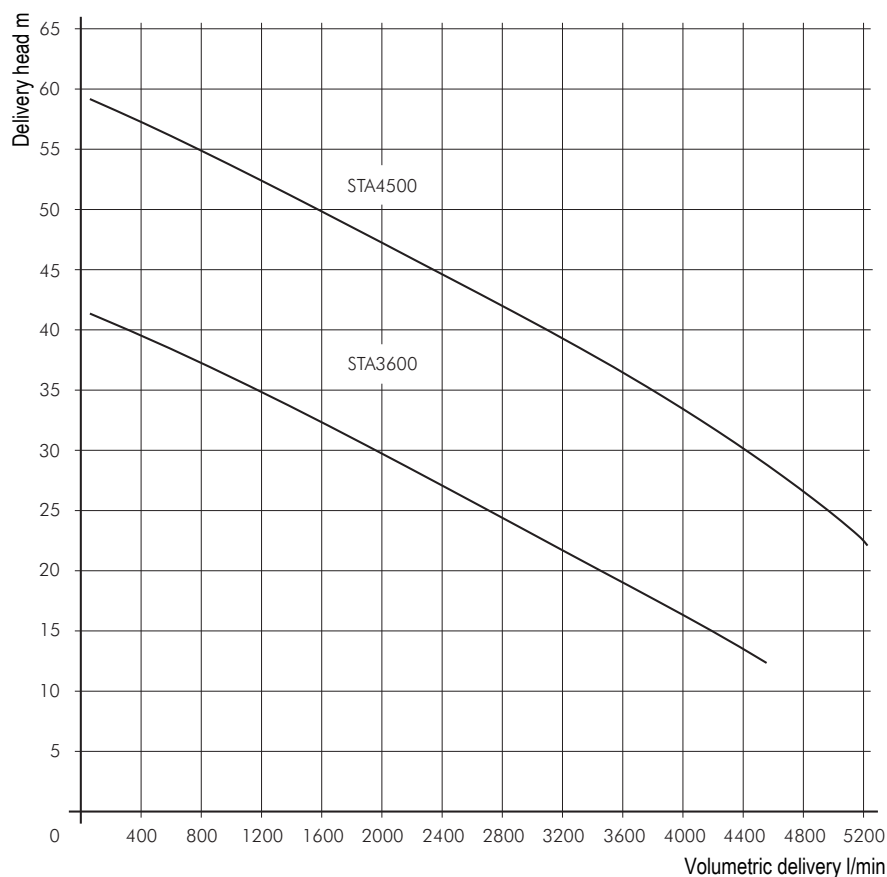

# Quick Suctioning Immersion Pumps

## TL50...TAL200

Axial/semi-open impellers

### TL50

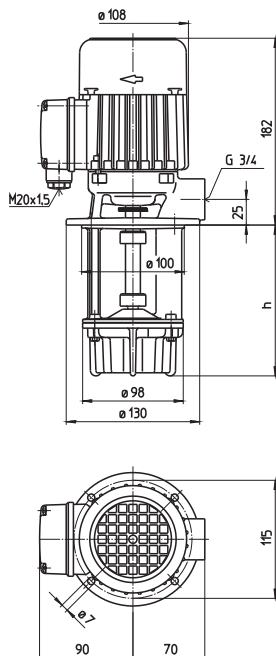

### TAL200

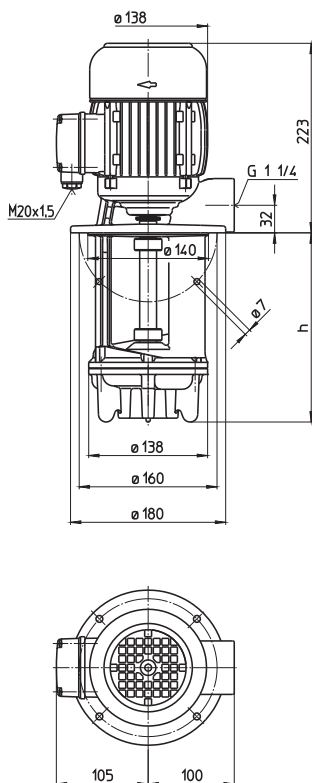

Type	Vol. del. at manom. del. head l/min /m	Height H mm	Depth of immersion h mm	Weight kg	Power kW	Voltage 3 ~ V	Fre- quency Hz	Rated current A	Speed 1/min
<b>TL50/110</b>	40/2	182	120	6.2	0.22	220-240	50	0.95	2700
<b>140</b>			145	6.4					
<b>190</b>			195	6.6					
<b>240</b>			245	7.0					
<b>290</b>			295	7.5					
<b>370</b>			375	8.1					
<b>TAL200/140</b>	200/4	223	140	13	0.55	220-240	50	2.50	2750
<b>220</b>			220	14					
<b>290</b>			290	15					
<b>370</b>			370	16					
<b>460</b>			460	17					
<b>570</b>			570	18					
						380-420	50	0.55	2700
						460	60	0.55	3200
						380-420	50	1.45	2750
						460	60	1.45	3250



### Quick Suctioning Immersion Pumps

equipped with the patented "BRINKMANN's Suction De-aeration System" are excellently suited to pumping **extremely inflated fluids** (emulsions resp. cooling/cutting oils) as they occur in heavy cutting when turning, milling or grinding. The quick suctioning immersion pumps reach stable working conditions as soon as the liquid level reaches the suction inlet.

### Applications

Types of fluid  
 water  
 coolants  
 cooling/cutting oils  
 Kinematic viscosity  
 ...90 mm<sup>2</sup>/s (90 cSt)  
 Pumping temperature  
 0...80° C

### Construction

Pump body	cast iron
Cover	cast iron
Impeller axial	cast iron
Impeller radial	brass
Shaft	steel
Optional: Impeller radial	cast steel

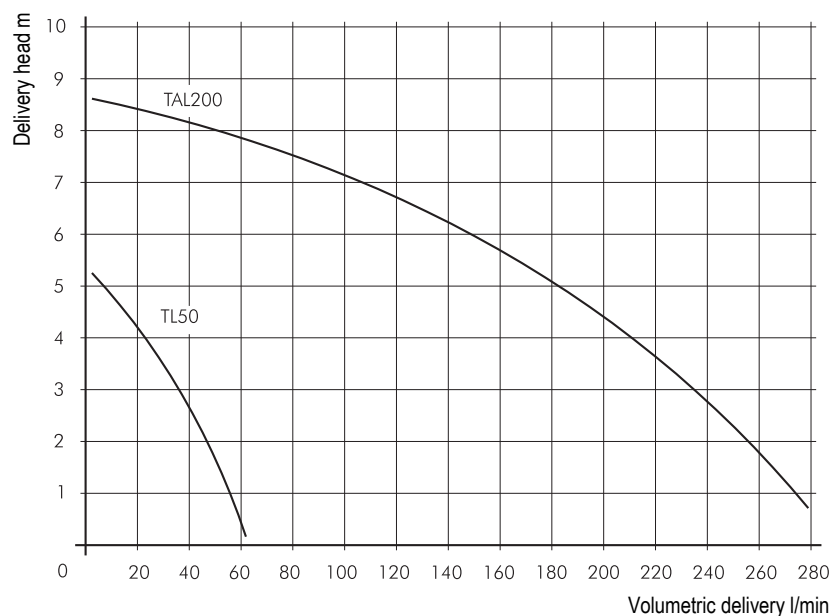

# Quick Suctioning Immersion Pumps



## TL/STL141...146

Axial/semi-open impellers

### TL141, 142

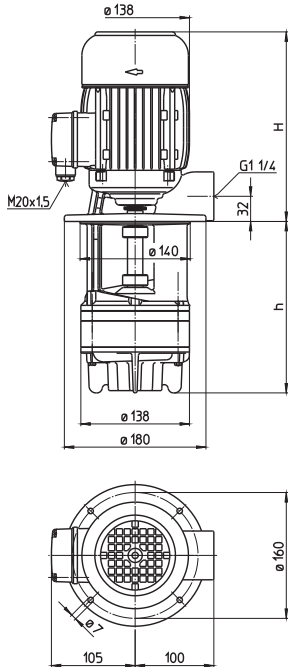

### STL141...146

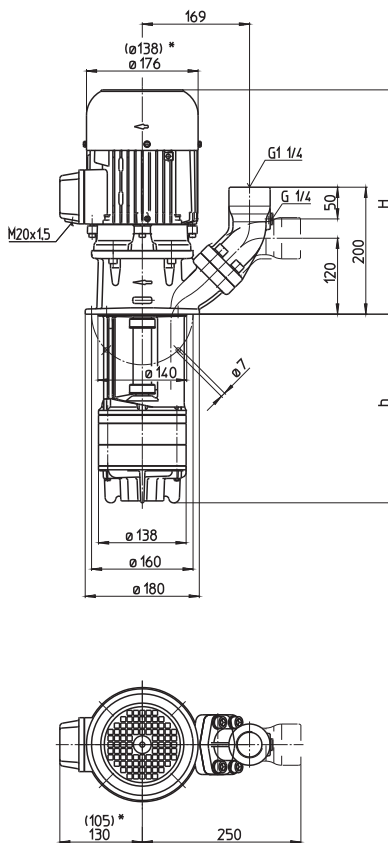

\*) Dimensions for STL141, 142

Type	Vol. del. at manom. del. head l/min /m	Height H mm	Depth of immersion h mm	Weight kg	Power kW	Voltage 3~ V	Fre- quency Hz	Rated current A	Speed 1/min
<b>TL141/150</b>	100/10	223	150	14.0	0.55	220-240	50	2.50	2750
<b>230</b>			230	14.5					
<b>300</b>			300	15.0					
<b>380</b>			380	15.5					
<b>470</b>			470	17.5					
<b>580</b>			580	19.0					
<b>TL142/180</b>	100/20	261	180	17	1.1	220-240	50	5.0	2700
<b>260</b>			260	18					
<b>330</b>			330	19					
<b>410</b>			410	20					
<b>500</b>			500	21					
<b>610</b>			610	22					
<b>STL141/150</b>	100/10	293	150	16.0	0.54	220-240	50	2.42	2800
<b>230</b>			230	16.5					
<b>300</b>			300	17.0					
<b>380</b>			380	17.5					
<b>470</b>			470	19.5					
<b>580</b>			580	21.0					
<b>STL142/180</b>	100/20	331	180	20	1.1	220-240	50	5.0	2700
<b>260</b>			260	21					
<b>330</b>			330	22					
<b>410</b>			410	23					
<b>500</b>			500	24					
<b>610</b>			610	25					
<b>STL143/220</b>	100/30	355	215	30	1.5	220-240	50	6.6	2850
<b>300</b>			295	31					
<b>370</b>			365	32					
<b>450</b>			445	33					
<b>540</b>			535	34					
<b>650</b>			645	35					
<b>STL144/250</b>	100/40	355	250	31	1.7	220-240	50	7.1	2850
<b>330</b>			330	32					
<b>400</b>			400	33					
<b>480</b>			480	34					
<b>570</b>			570	35					
<b>680</b>			680	36					
<b>STL145/300</b>	100/50	395	300	36	2.2	220-240	50	9.2	2850
<b>380</b>			380	37					
<b>450</b>			450	38					
<b>530</b>			530	39					
<b>620</b>			620	40					
<b>730</b>			730	41					
<b>STL146/330</b>	100/62	405	335	36	2.6	220-240	50	10.9	2850
<b>410</b>			415	37					
<b>480</b>			485	38					
<b>560</b>			565	39					

### Quick Suctioning Immersion Pumps

equipped with the patented "BRINK-MANN's Suction De-aeration System" are excellently suited to pumping **extremely inflated fluids** (emulsions resp. cooling/cutting oils) as they occur in heavy cutting when turning, milling or grinding. The quick suctioning immersion pumps reach stable working conditions as soon as the liquid level reaches the suction inlet.

The STL serie offers a **(SAE) flange** with pressure gauge connection port. The flange can be rotated for either horizontal or vertical pipe connections.

### Applications

Types of fluid  
 water  
 coolants  
 cooling/cutting oils  
 Kinematic viscosity  
 ...90 mm<sup>2</sup>/s (90 cSt)  
 Pumping temperature  
 0...80° C

### Construction

Pump body	cast iron
Cover	cast iron
Impeller axial	cast iron
Impeller radial	brass
Shaft	steel
Optional: Impeller radial	cast steel

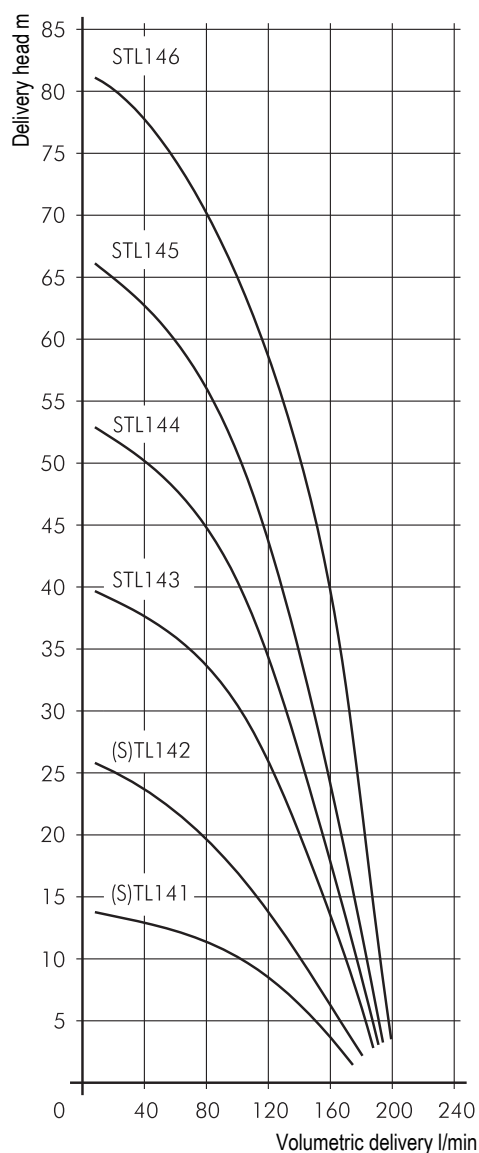

# Quick Suctioning Immersion Pumps



## TAL/SAL301...306

Axial/semi-open impellers

### TAL302

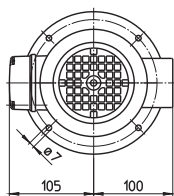
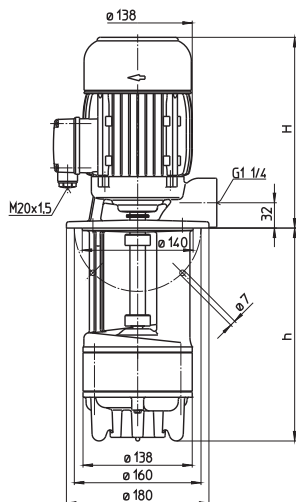

### SAL301...306

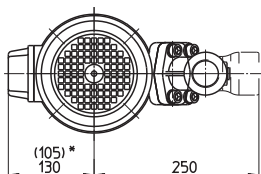
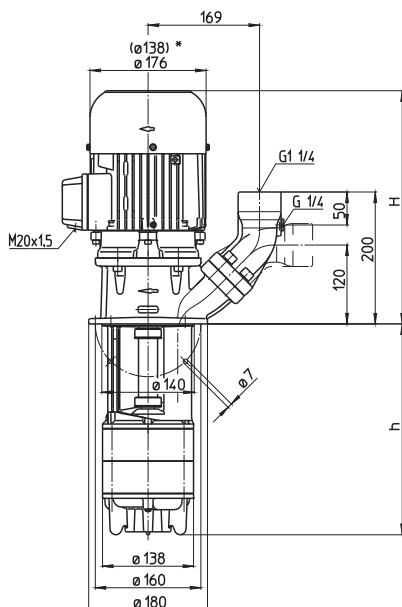

\*) Dimensions for SAL301, 302

Type	Vol. del. at manom. del. head l/min /m	Height H mm	Depth of immersion h mm	Weight kg	Power kW	Voltage 3 ~ V	Fre- quency Hz	Rated current A	Speed 1/min
<b>TAL302/190</b>	160/12	261	190	18.5	1.1	220-240	50	5.0	2700
<b>270</b>			270	19.5		380-420	50	2.9	2700
<b>340</b>			340	20.5		460	60	2.9	3300
<b>420</b>			420	21.5					
<b>510</b>			510	22.5					
<b>620</b>			620	23.5					
<b>SAL301/140</b>	160/7	293	140	13.5	0.54	220-240	50	2.42	2800
<b>220</b>			220	14.5		380-420	50	1.40	2800
<b>290</b>			290	15.5		460	60	1.40	3300
<b>370</b>			370	16.5					
<b>460</b>			460	17.5					
<b>570</b>			570	18.5					
<b>SAL302/190</b>	160/12	331	190	21	1.1	220-240	50	5.0	2700
<b>270</b>			270	22		380-420	50	2.9	2700
<b>340</b>			340	23		460	60	2.9	3300
<b>420</b>			420	24					
<b>510</b>			510	25					
<b>620</b>			620	26					
<b>SAL303/240</b>	160/18	355	240	35	1.5	220-240	50	6.6	2850
<b>320</b>			320	36		380-420	50	3.8	2850
<b>390</b>			390	37		460	60	3.8	3400
<b>470</b>			470	38					
<b>560</b>			560	39					
<b>670</b>			670	40					
<b>870</b>			870	42					
<b>1020</b>			1020	43					
<b>SAL304/290</b>	160/24	395	290	42	1.9	220-240	50	8.5	2850
<b>370</b>			370	43		380-420	50	4.9	2850
<b>440</b>			440	44		460	60	4.9	3400
<b>520</b>			520	45					
<b>610</b>			610	46					
<b>720</b>			720	47					
<b>920</b>			920	49					
<b>1070</b>			1070	50					
<b>SAL305/340</b>	160/29	395	340	45	2.2	220-240	50	9.2	2850
<b>420</b>			420	46		380-420	50	5.3	2850
<b>490</b>			490	47		460	60	5.3	3400
<b>570</b>			570	48					
<b>660</b>			660	49					
<b>770</b>			770	50					
<b>970</b>			970	52					
<b>1120</b>			1120	53					
<b>SAL306/390</b>	160/37	405	390	50	2.6	220-240	50	10.9	2850
<b>470</b>			470	51		380-420	50	6.3	2850
<b>540</b>			540	52		460	60	6.3	3400
<b>620</b>			620	53					
<b>710</b>			710	55					
<b>820</b>			820	56					
<b>1020</b>			1020	57					

### Quick Suctioning Immersion Pumps

equipped with the patented "BRINKMANN's Suction De-aeration System" are excellently suited to pumping **extremely inflated fluids** (emulsions resp. cooling/cutting oils) as they occur in heavy cutting when turning, milling or grinding. The quick suctioning immersion pumps reach stable working conditions as soon as the liquid level reaches the suction inlet.

The SAL serie offers a **(SAE) flange** with pressure gauge connection port. The flange can be rotated for either horizontal or vertical pipe connections.

### Applications

Types of fluid  
 water  
 coolants  
 cooling/cutting oils  
 Kinematic viscosity  
 ...90 mm<sup>2</sup>/s (90 cSt)  
 Pumping temperature  
 0...80° C

### Construction

Pump body	cast iron
Cover	cast iron
Impeller axial	cast steel
Impeller radial	brass
Shaft	steel
Optional: Impeller radial	cast steel

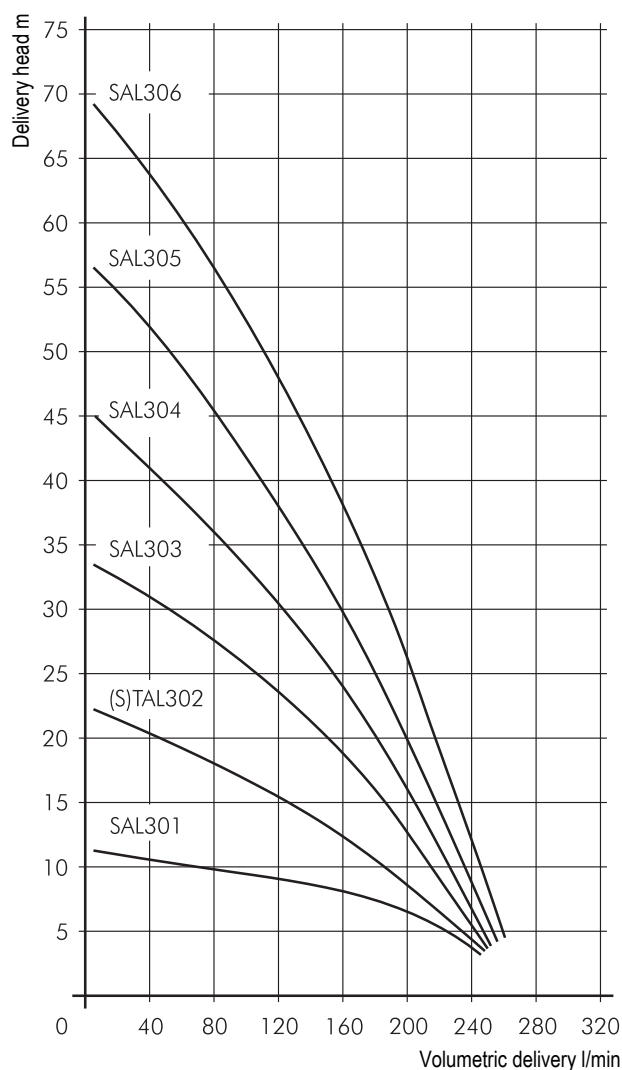

# Quick Suctioning Immersion Pumps



## SAL401...409

Axial/semi-open impellers

### SAL401...409

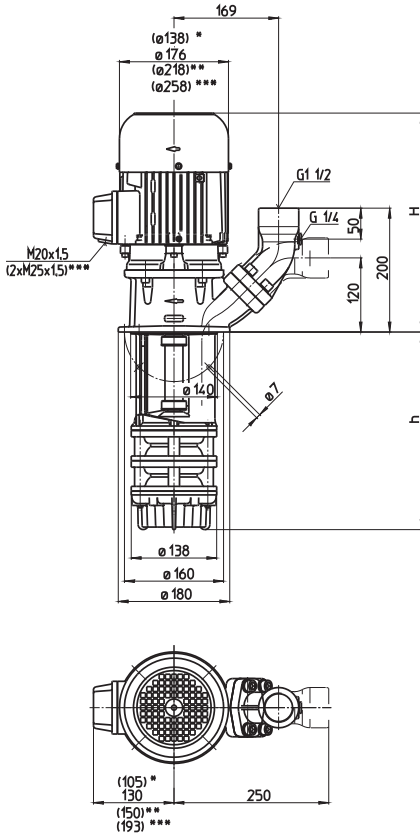

- \*) Dimensions for SAL401
- \*\*) Dimensions for SAL406, 407
- \*\*\*) Dimensions for SAL409

Type	Vol. del. at manom. del. head l/min / m	Height H mm	Depth of immersion h mm	Weight kg	Power kW	Voltage 3 ~ V	Fre- quency Hz	Rated current A	Speed 1/min
<b>SAL401/140</b>	250/5	311	140	16	0.85	220-240	50	4.3	2800
<b>220</b>			220	17					
<b>290</b>			290	18					
<b>370</b>			370	19					
<b>460</b>			460	20					
<b>570</b>			570	21					
<b>770</b>			770	22	1.3	220-240	50	5.2	2850
<b>920</b>			920	23					
<b>SAL402/190</b>	250/11	355	190	31					
<b>270</b>			270	32					
<b>340</b>			340	33					
<b>420</b>			420	34					
<b>510</b>			510	35	1.7	220-240	50	7.1	2850
<b>620</b>			620	37					
<b>820</b>			820	38					
<b>970</b>			970	39					
<b>SAL403/240</b>	250/19	355	240	33					
<b>320</b>			320	34					
<b>390</b>			390	35					
<b>470</b>			470	36	2.2	220-240	50	9.2	2850
<b>560</b>			560	37					
<b>670</b>			670	38					
<b>870</b>			870	40					
<b>1020</b>			1020	41					
<b>SAL404/290</b>	250/25	395	290	39					
<b>370</b>			370	40					
<b>440</b>			440	41					
<b>520</b>			520	42	2.6	220-240	50	10.9	2850
<b>610</b>			610	43					
<b>720</b>			720	44					
<b>920</b>			920	46					
<b>1070</b>			1070	47					
<b>SAL405/340</b>	250/30	405	340	43					
<b>420</b>			420	44					
<b>490</b>			490	45					
<b>570</b>			570	46	3.3	220-240	50	13.8	2900
<b>660</b>			660	47					
<b>770</b>			770	48					
<b>970</b>			970	51					
<b>1120</b>			1120	52					
<b>SAL406/390</b>	250/38	445	390	56					
<b>470</b>			470	57					
<b>540</b>			540	58					
<b>620</b>			620	59	4.0	220-240	50	16.5	2900
<b>710</b>			710	60					
<b>820</b>			820	61					
<b>1020</b>			1020	62					
<b>SAL407/440</b>	250/44	445	440	60					
<b>520</b>			520	61					
<b>590</b>			590	62					
<b>670</b>			670	63	5.5	220-240	50	22.0	2900
<b>760</b>			760	64					
<b>870</b>			870	65					
<b>SAL409/540</b>	250/53	480	540	81					
<b>620</b>			620	82					
<b>690</b>			690	83					
<b>770</b>			770	84					
<b>860</b>			860	85	4.0	220-240	50	9.5	2900
<b>970</b>			970	86					
					5.5	220-240	50	12.5	2900
					4.0	220-240	60	9.5	3450
					5.5	220-240	60	12.5	3450

### Quick Suctioning Immersion Pumps

equipped with the patented "BRINKMANN's Suction De-aeration System" are excellently suited to pumping **extremely inflated fluids** (emulsions resp. cooling/cutting oils) as they occur in heavy cutting when turning, milling or grinding. The quick suctioning immersion pumps reach stable working conditions as soon as the liquid level reaches the suction inlet.

The SAL serie offers a **(SAE) flange** with pressure gauge connection port. The flange can be rotated for either horizontal or vertical pipe connections.

### Applications

Types of fluid  
 water  
 coolants  
 cooling/cutting oils  
 Kinematic viscosity  
 ...90 mm<sup>2</sup>/s (90 cSt)  
 Pumping temperature  
 0...80° C

### Construction

Pump body	cast iron
Cover	cast iron
Impeller axial	cast steel
Impeller radial	brass
Shaft	steel
Optional: Impeller radial	cast steel

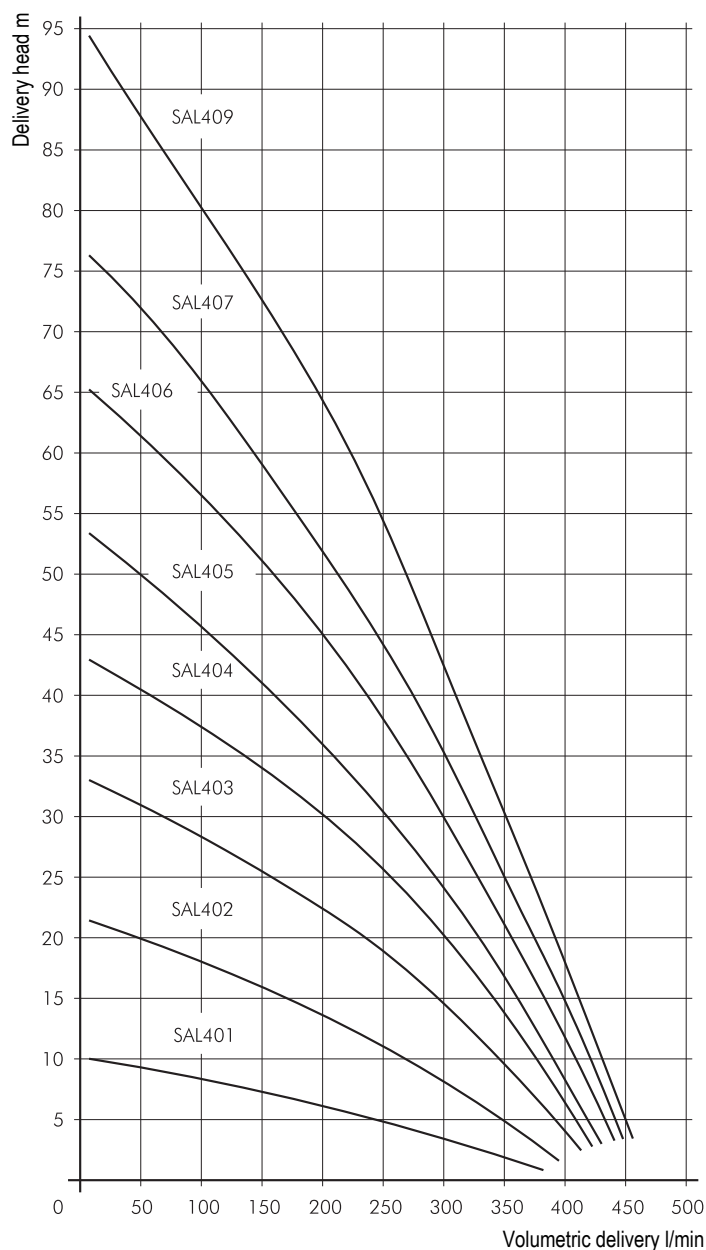



# Quick Suctioning Immersion Pumps

## SAL601...609

Axial/semi-open impellers

### SAL601...609

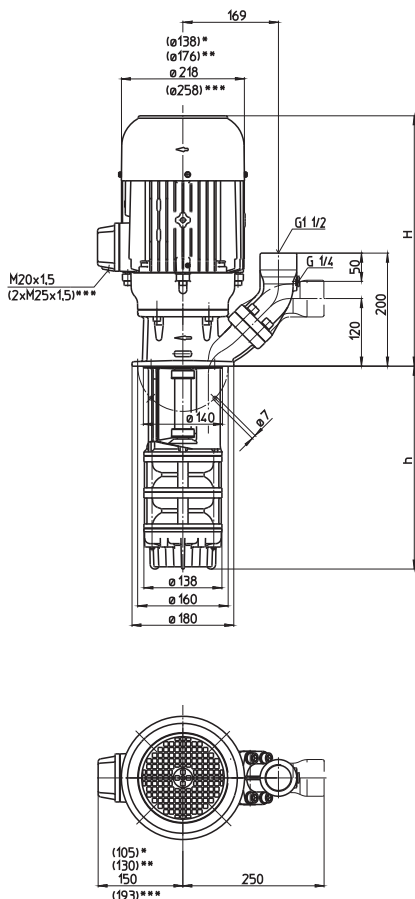

- \*) Dimensions for SAL601
- \*\*) Dimensions for SAL602
- \*\*\*) Dimensions for SAL605, 607, 609

Type	Vol. del. at manom. del. head l/min / m	Height H mm	Depth of immersion h mm	Weight kg	Power kW	Voltage 3 ~ V	Fre- quency Hz	Rated current A	Speed 1/min
<b>SAL601/150</b>	400/3	311	150	17	0.92	220-240	50	4.7	2700
<b>230</b>			230	18					
<b>300</b>			300	19					
<b>380</b>			380	20					
<b>470</b>			470	21					
<b>580</b>			580	22					
<b>780</b>			780	25					
<b>930</b>			930	26					
<b>SAL602/220</b>	400/10	395	215	35	2.2	220-240	50	9.2	2850
<b>300</b>			295	36					
<b>370</b>			365	37					
<b>450</b>			445	38					
<b>540</b>			535	39					
<b>650</b>			645	41					
<b>850</b>			845	43					
<b>1000</b>			995	44					
<b>SAL603/280</b>	400/16	445	280	50	3.3	220-240	50	13.8	2900
<b>360</b>			360	51					
<b>430</b>			430	52					
<b>510</b>			510	53					
<b>600</b>			600	54					
<b>710</b>			710	55					
<b>910</b>			910	57					
<b>1060</b>			1060	58					
<b>SAL604/350</b>	400/23	445	345	55	4.0	220-240	50	16.5	2900
<b>430</b>			425	56					
<b>500</b>			495	57					
<b>580</b>			575	58					
<b>670</b>			665	59					
<b>780</b>			775	60					
<b>980</b>			975	62					
<b>1130</b>			1125	63					
<b>SAL605/410</b>	400/32	480	410	73	5.5	220-240	50	22.0	2900
<b>490</b>			490	74					
<b>560</b>			560	75					
<b>640</b>			640	76					
<b>730</b>			730	77					
<b>840</b>			840	78					
<b>1040</b>			1040	79					
<b>SAL607/540</b>	400/44	520	540	91	7.5	220-240	50	29	2900
<b>620</b>			620	92					
<b>690</b>			690	93					
<b>770</b>			770	94					
<b>860</b>			860	95					
<b>970</b>			970	96					
<b>SAL609/670</b>	400/58	570	670	100	10.0	220-240	50	40	2900
<b>750</b>			750	101					
<b>820</b>			820	102					
<b>900</b>			900	103					
<b>1000</b>			1000	104					
<b>1100</b>			1100	105					

### Quick Suctioning Immersion Pumps

equipped with the patented "BRINK-MANN's Suction De-aeration System" are excellently suited to pumping **extremely inflated fluids** (emulsions resp. cooling/cutting oils) as they occur in heavy cutting when turning, milling or grinding. The quick suctioning immersion pumps reach stable working conditions as soon as the liquid level reaches the suction inlet.

The SAL serie offers a **(SAE) flange** with pressure gauge connection port. The flange can be rotated for either horizontal or vertical pipe connections.

### Applications

Types of fluid  
 water  
 coolants  
 cooling/cutting oils  
 Kinematic viscosity  
 ...90 mm<sup>2</sup>/s (90 cSt)  
 Pumping temperature  
 0...80° C

### Construction

Pump body	cast iron
Cover	cast iron
Impeller axial	cast steel
Impeller radial	brass
Shaft	steel
Optional: Impeller radial	cast steel

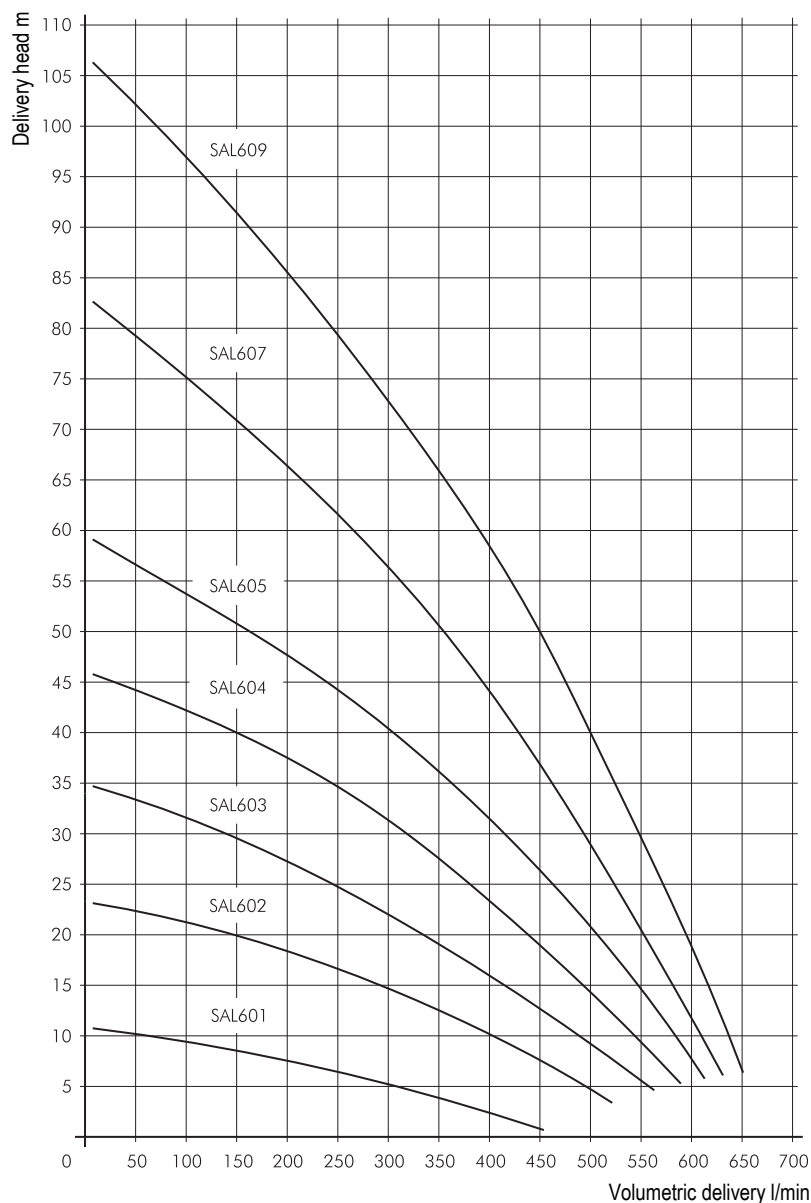

# Quick Suctioning Immersion Pumps

## SAL901...904

Axial/semi-open impellers

### SAL901, 902 SAL903, 904

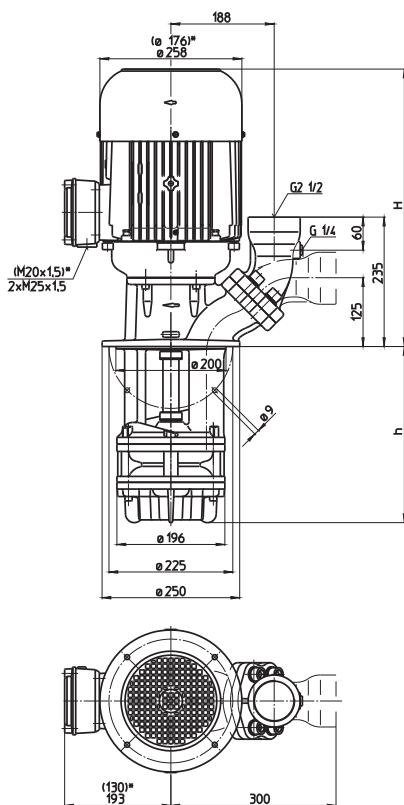

\*) Dimensions for SAL901

Type	Vol. del. at manom. del. head l/min /m	Height H mm	Depth of im- mersion h mm	Weight kg	Power kW	Voltage 3 ~ V	Fre- quency Hz	Rated current A	Speed 1/min
<b>SAL901/220</b>	600/12	429	220	50	2.6	220-240	50	10.9	2850
<b>320</b>			320	52					
<b>450</b>			450	54					
<b>570</b>			570	57					
<b>770</b>			770	62					
<b>1000</b>			1000	69					
<b>1120</b>			1120	73					
<b>SAL902/290</b>	600/21	504	290	83	5.5	220-240	50	22.0	2900
<b>390</b>			390	86					
<b>520</b>			520	90					
<b>640</b>			640	94					
<b>840</b>			840	99					
<b>1070</b>			1070	106					
<b>1190</b>			1190	111					
<b>SAL903/360</b>	600/33	542	360	103	7.5	220-240	50	29	2900
<b>460</b>			460	106					
<b>590</b>			590	110					
<b>710</b>			710	114					
<b>910</b>			910	119					
<b>1140</b>			1140	126					
<b>SAL904/430</b>	600/48	592	430	122	10.0	220-240	50	40	2900
<b>530</b>			530	125					
<b>660</b>			660	129					
<b>780</b>			780	133					
<b>980</b>			980	138					
<b>1210</b>			1210	145					
						460	60	23	3450

### Quick Suctioning Immersion Pumps

equipped with the patented "BRINKMANN's Suction De-aeration System" are excellently suited to pumping **extremely inflated fluids** (emulsions resp. cooling/cutting oils) as they occur in heavy cutting when turning, milling or grinding. The quick suctioning immersion pumps reach stable working conditions as soon as the liquid level reaches the suction inlet.

The SAL serie offers a **flange** with pressure gauge connection port.

The flange can be rotated for either horizontal or vertical pipe connections.

### Applications

Types of fluid  
 water  
 coolants  
 cooling/cutting oils  
 Kinematic viscosity  
 ...90 mm<sup>2</sup>/s (90 cSt)  
 Pumping temperature  
 0...80° C

### Construction

Pump body	cast iron
Cover	cast iron
Impeller axial	cast steel
Impeller radial	cast steel
Shaft	steel

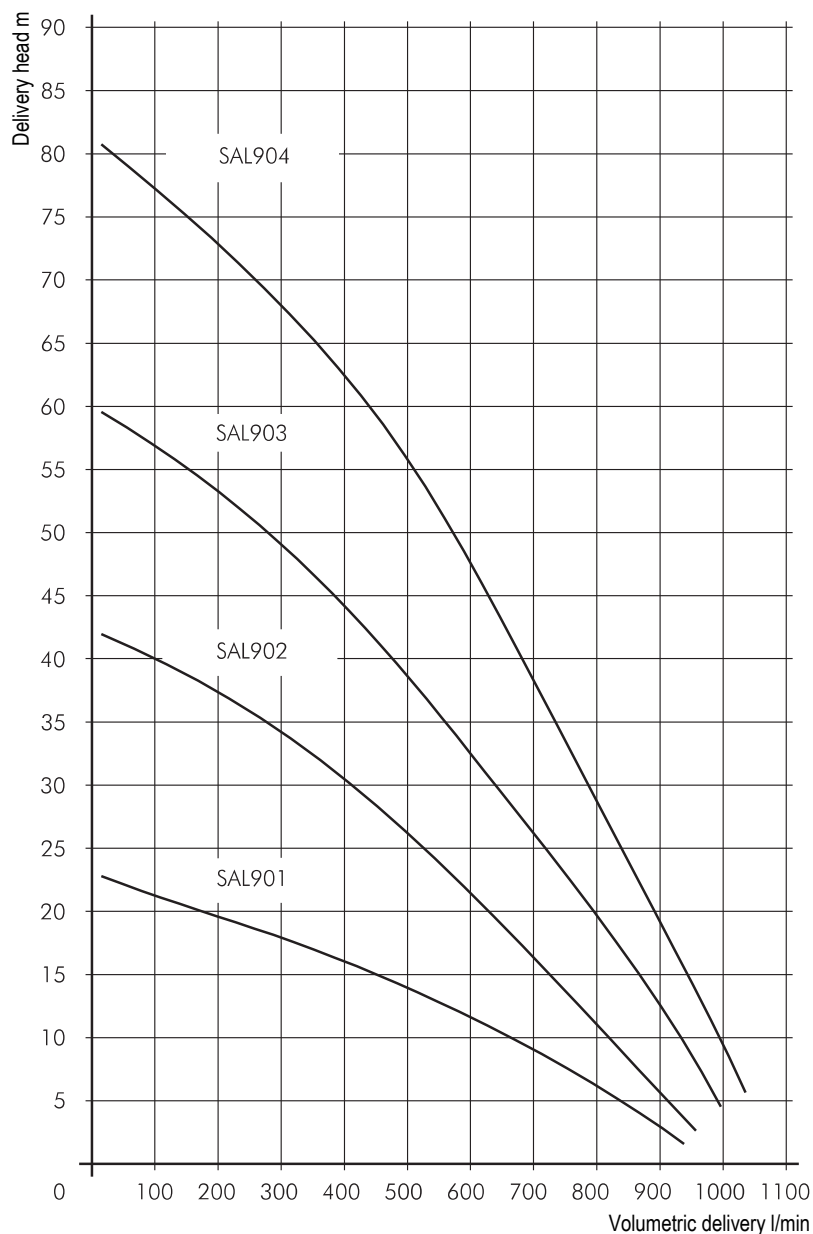

# Quick Suctioning Immersion Pumps

## SAL1001...1006

Axial/semi-open impellers

### SAL1001...1004

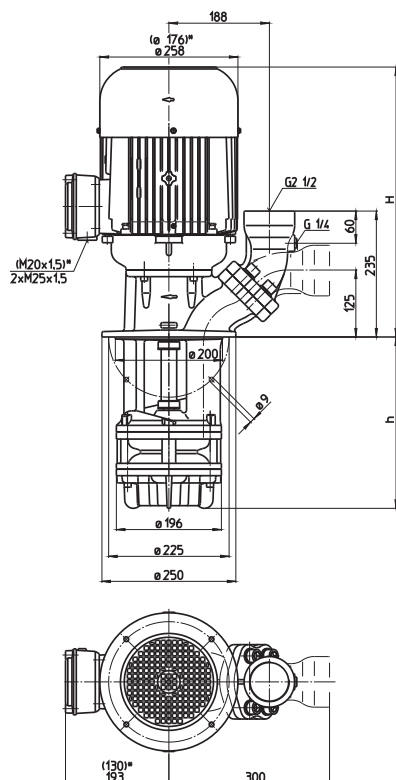

### SAL1006

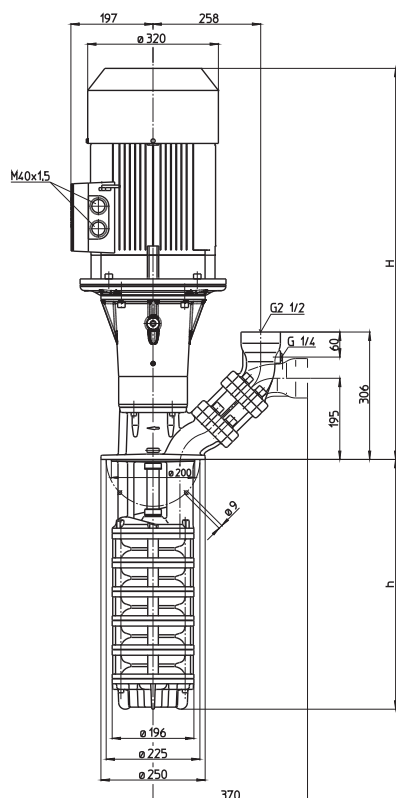

\*) Dimensions for SAL1001

Type	Vol. del. at manom. del. head l/min / m	Height H mm	Depth of immersion h mm	Weight kg	Power kW	Voltage 3 ~ V	Fre- quency Hz	Rated current A	Speed 1/min
<b>SAL1001/230</b>	600/14	429	230	51	2.6	220-240	50	10.9	2850
<b>330</b>			330	53		380-420	50	6.3	2850
<b>460</b>			460	55		460	60	6.3	3400
<b>580</b>			580	58					
<b>780</b>			780	63					
<b>1010</b>			1010	70					
<b>1130</b>			1130	74					
<b>SAL1002/310</b>	600/27	504	310	84	5.5	220-240	50	22.0	2900
<b>410</b>			410	87		380-420	50	12.5	2900
<b>540</b>			540	91		460	60	12.5	3450
<b>660</b>			660	95					
<b>860</b>			860	100					
<b>1090</b>			1090	117					
<b>1210</b>			1210	122					
<b>SAL1003/390</b>	600/40	542	390	104	7.5	220-240	50	29	2900
<b>490</b>			490	107		380-420	50	17	2900
<b>620</b>			620	111		460	60	17	3450
<b>740</b>			740	115					
<b>940</b>			940	120					
<b>1170</b>			1170	127					
<b>SAL1004/470</b>	600/55	592	470	128	10.0	220-240	50	40	2900
<b>570</b>			570	131		380-420	50	23	2900
<b>700</b>			700	135		460	60	23	3450
<b>820</b>			820	139					
<b>1020</b>			1020	144					
<b>1250</b>			1250	149					
<b>SAL1006/630</b>	600/85	938	630	169	18.5	400	50	32	2940
<b>730</b>			730	172					
<b>860</b>			860	176	21.3	460	60	31.5	3540
<b>980</b>			980	182					

### Quick Suctioning Immersion Pumps

equipped with the patented "BRINK-MANN's Suction De-aeration System" are excellently suited to pumping **extremely inflated fluids** (emulsions resp. cooling/cutting oils) as they occur in heavy cutting when turning, milling or grinding. The quick suctioning immersion pumps reach stable working conditions as soon as the liquid level reaches the suction inlet.

The SAL serie offers a **flange** with pressure gauge connection port.

The flange can be rotated for either horizontal or vertical pipe connections.

### Applications

Types of fluid  
 water  
 coolants  
 cooling/cutting oils  
 Kinematic viscosity  
 ...90 mm<sup>2</sup>/s (90 cSt)  
 Pumping temperature  
 0...80° C

### Construction

Pump body	cast iron
Cover	cast iron
Impeller axial	cast steel
Impeller radial	cast steel
Shaft	steel

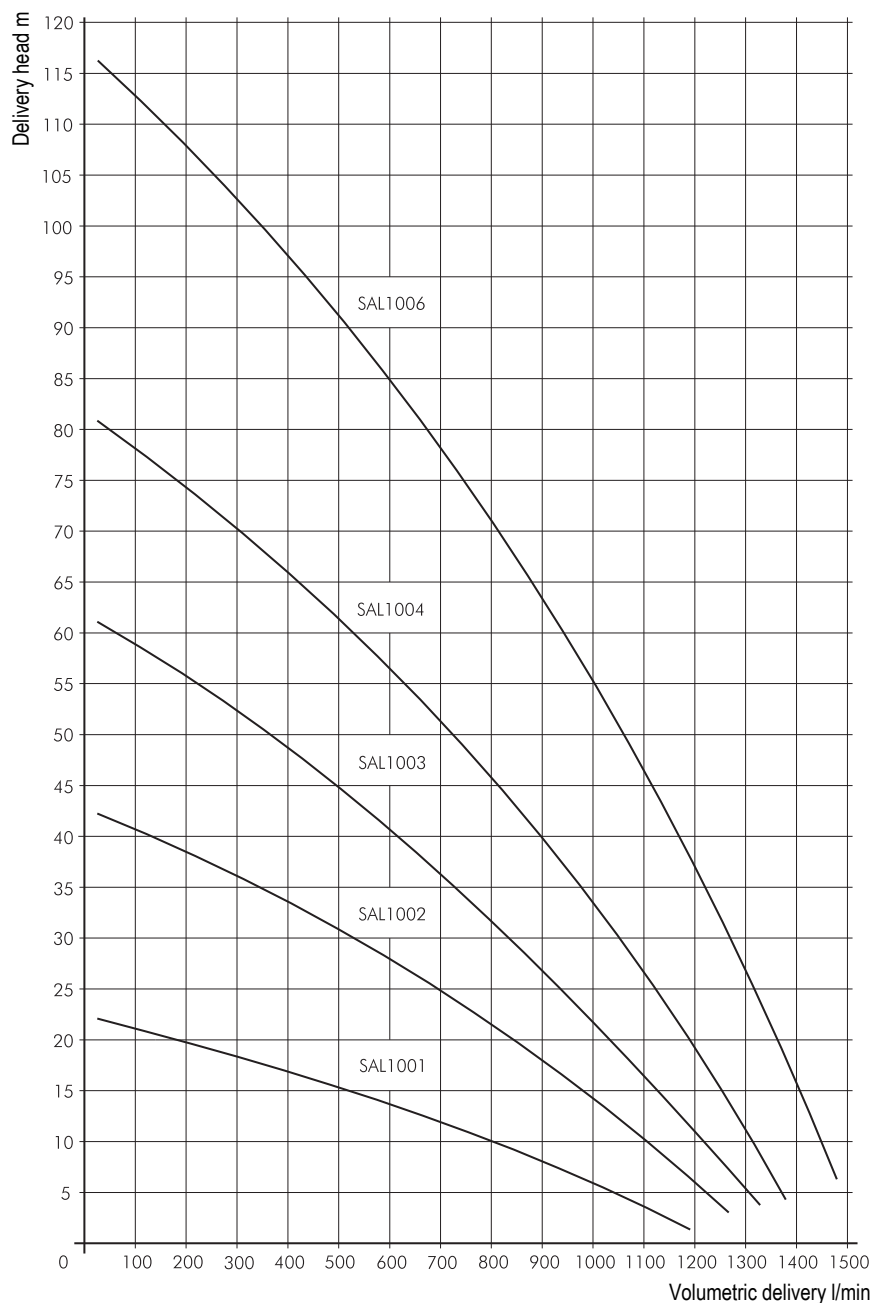

# Quick Suctioning Immersion Pumps

## SAL1301...1303

Axial/semi-open impellers

### SAL1301, 1302 SAL1303

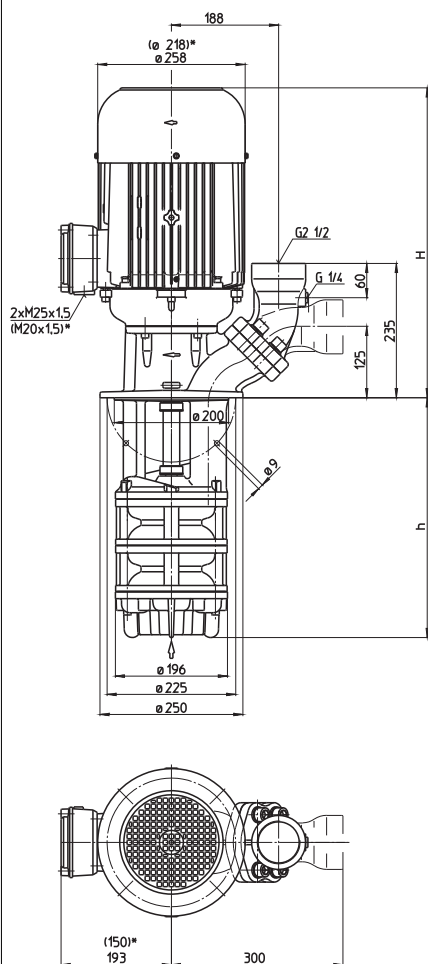

\*) Dimensions for SAL1301

Type	Vol. del. at manom. del. head l/min /m	Height H mm	Depth of immersion h mm	Weight kg	Power kW	Voltage 3 ~ V	Fre- quency Hz	Rated current A	Speed 1/min
<b>SAL1301/230</b>	900/11	468	230	58	4.0	220-240	50	16.5	2900
<b>330</b>			330	60					
<b>460</b>			460	62					
<b>580</b>			580	66					
<b>780</b>			780	72					
<b>1010</b>			1010	77					
<b>1130</b>			1130	80					
<b>SAL1302/310</b>	900/21	542	310	96	7.5	220-240	50	29	2900
<b>410</b>			410	99					
<b>540</b>			540	103					
<b>660</b>			660	107					
<b>860</b>			860	112					
<b>1090</b>			1090	119					
<b>SAL1303/390</b>	900/35	592	390	116	10.0	220-240	50	40	2900
<b>490</b>			490	119					
<b>620</b>			620	125					
<b>740</b>			740	130					
<b>940</b>			940	135					
<b>1170</b>			1170	142					
						380-420	50	9.5	2900
						460	60	9.5	3450
						380-420	50	17	2900
						460	60	17	3450
						380-420	50	23	2900
						460	60	23	3450



### Quick Suctioning Immersion Pumps

equipped with the patented "BRINKMANN's Suction De-aeration System" are excellently suited to pumping **extremely inflated fluids** (emulsions resp. cooling/cutting oils) as they occur in heavy cutting when turning, milling or grinding.

The quick suctioning immersion pumps reach stable working conditions as soon as the liquid level reaches the suction inlet.

The SAL serie offers a **flange** with pressure gauge connection port.

The flange can be rotated for either horizontal or vertical pipe connections.

### Applications

Types of fluid  
 water  
 coolants  
 cooling/cutting oils  
 Kinematic viscosity  
 ...90 mm<sup>2</sup>/s (90 cSt)  
 Pumping temperature  
 0...80° C

### Construction

Pump body	cast iron
Cover	cast iron
Impeller axial	cast steel
Impeller radial	cast steel
Shaft	steel

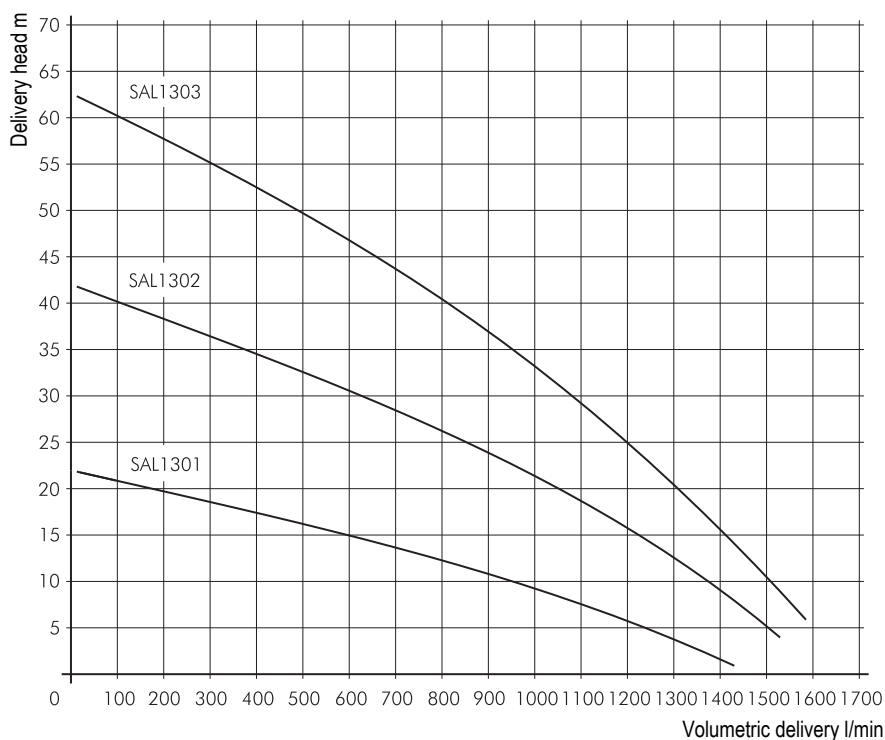

# Quick Suctioning Immersion Pumps

## SAL1600...2500

Axial/semi-open impellers

### SAL1600, 2000

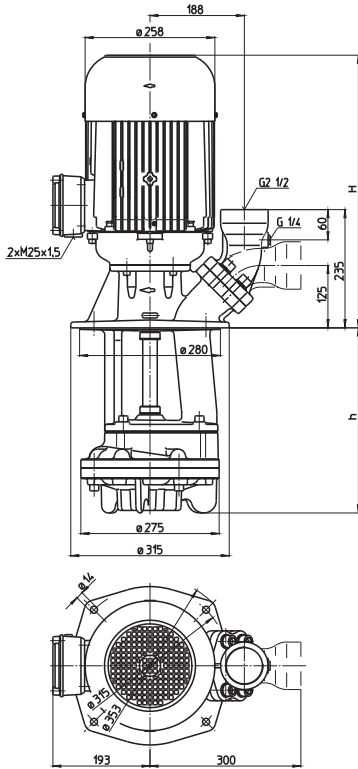

### SAL1602, 2500

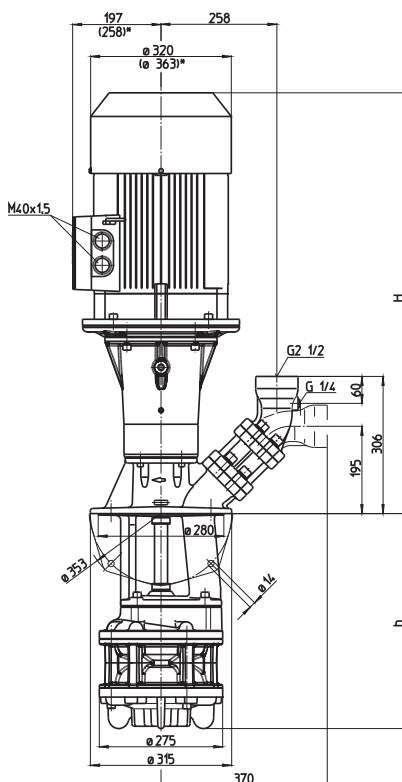

\*) Dimensions for SAL2002

Type	Vol. del. at manom. del. head l/min /m	Height H mm	Depth of immersion h mm	Weight kg	Power kW	Voltage 3 ~ V	Fre- quency Hz	Rated current A	Speed 1/min
<b>SAL1600/310</b>	1300/15	542	310	102	7.5	220-240	50	29	2900
<b>440</b>			440	104					
<b>560</b>			560	106					
<b>810</b>			810	112					
<b>1060</b>			1060	114					
<b>SAL2000/310</b>	1600/15	592	310	121	10.0	220-240	50	40	2900
<b>440</b>			440	123					
<b>560</b>			560	126					
<b>810</b>			810	132					
<b>1060</b>			1060	134					
<b>SAL1602/420</b>	1300/37	938	420	180	18.5	400	50	32	2940
<b>550</b>			550	182					
<b>670</b>			670	184					
<b>920</b>			920	190					
<b>1170</b>			1170	192					
<b>SAL2002/420</b>	1600/45	1022	420	243	22.0	400	50	39	2945
<b>550</b>			550	247					
<b>670</b>			670	251					
<b>920</b>			920	260					
<b>1170</b>			1170	264					
<b>SAL2500/340</b>	2200/20	938	340	149	18.5	400	50	32	2940
<b>470</b>			470	150					
<b>590</b>			590	152					
<b>840</b>			840	169					
<b>1090</b>			1090	171					
					21.3	460	60	31.5	3540

### Quick Suctioning Immersion Pumps

equipped with the patented "BRINK-MANN's Suction De-aeration System" are excellently suited to pumping **extremely inflated fluids** (emulsions resp. cooling/cutting oils) as they occur in heavy cutting when turning, milling or grinding. The quick suctioning immersion pumps reach stable working conditions as soon as the liquid level reaches the suction inlet.

The SAL serie offers a **flange** with pressure gauge connection port.

The flange can be rotated for either horizontal or vertical pipe connections.

### Applications

Types of fluid  
 water  
 coolants  
 cooling/cutting oils  
 Kinematic viscosity  
 ...90 mm<sup>2</sup>/s (90 cSt)  
 Pumping temperature  
 0...80° C

### Construction

Pump body	cast iron
Cover	cast iron
Impeller axial	cast steel
Impeller radial	cast steel
Shaft	steel

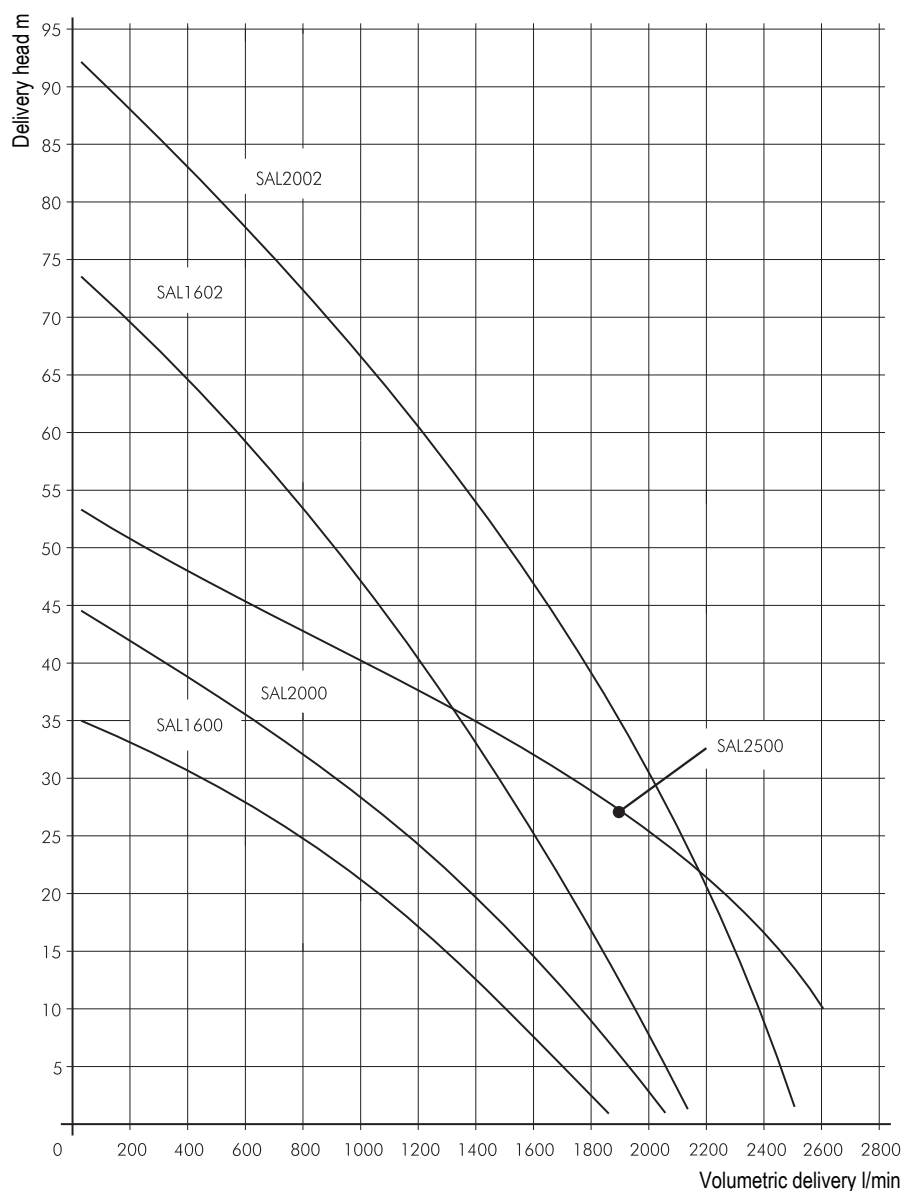

# Quick Suctioning Immersion Pumps

## TGL/SGL331...333

Axial/semi-open impellers

### TGL331

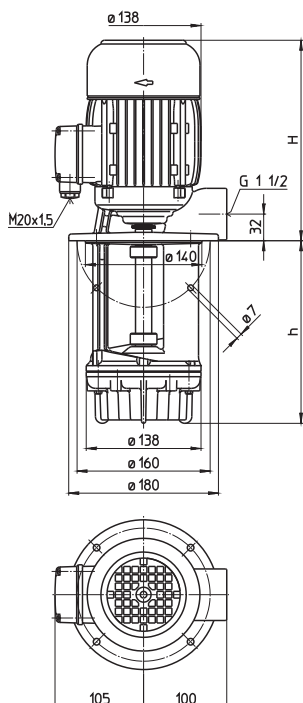

### SGL331...333

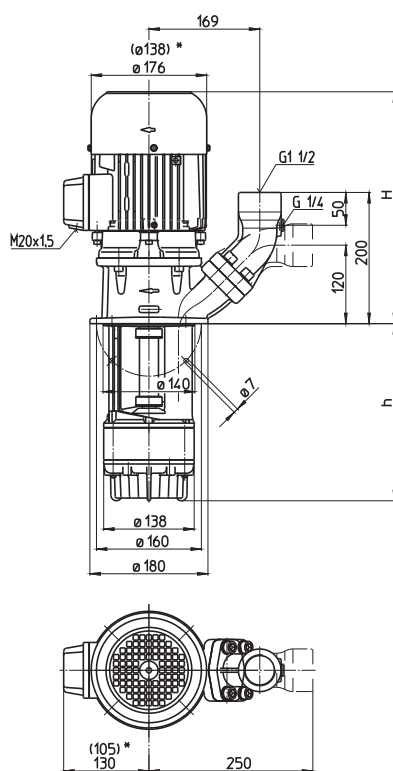

\*) Dimensions for SGL331

Type	Vol. del. at manom. del. head l/min / m	Height H mm	Depth of immersion h mm	Weight kg	Power kW	Voltage 3 ~ V	Fre- quency Hz	Rated current A	Speed 1/min
<b>TGL331/140</b>	200/5	241	140	13.5	0.85	220-240	50	4.3	2800
<b>220</b>			220	14.5					
<b>290</b>			290	15.5					
<b>370</b>			370	16.5					
<b>460</b>			460	17.5					
<b>570</b>			570	18.5					
<b>SGL331/140</b>	200/5	311	140	16	0.85	220-240	50	4.3	2800
<b>220</b>			220	17					
<b>290</b>			290	18					
<b>370</b>			370	19					
<b>460</b>			460	20					
<b>570</b>			570	21					
<b>770</b>			770	22					
<b>920</b>			920	23					
<b>SGL332/190</b>	200/12	355	190	31	1.3	220-240	50	5.2	2850
<b>270</b>			270	32					
<b>340</b>			340	33					
<b>420</b>			420	34					
<b>510</b>			510	35					
<b>620</b>			620	37					
<b>820</b>			820	38					
<b>970</b>			970	39					
<b>SGL333/240</b>	200/19	355	240	33	1.7	220-240	50	7.1	2850
<b>320</b>			320	34					
<b>390</b>			390	35					
<b>470</b>			470	37					
<b>560</b>			560	38					
<b>670</b>			670	39					
<b>870</b>			870	40					
<b>1020</b>			1020	41					

### Quick Suctioning Immersion Pumps

series TGL/SGL equipped with the patented "BRINKMANN's Suction De-aeration System" are excellently suited to pumping **extremely inflated fluids** (grinding oils) as they occur in **high-speed grinding**.

The quick suctioning immersion pumps reach stable working conditions as soon as the liquid level reaches the suction inlet.

The SGL serie offers a **(SAE) flange** with pressure gauge connection port.

The flange can be rotated for either horizontal or vertical pipe connections.

### Applications

Types of fluid  
 water  
 coolants  
 cooling/cutting oils  
 grinding oils  
 Kinematic viscosity  
 ...90 mm<sup>2</sup>/s (90 cSt)  
 Pumping temperature  
 0...80° C

### Construction

Pump body	cast iron
Cover	cast iron
Impeller axial	cast steel
Impeller radial	cast steel
Shaft	steel

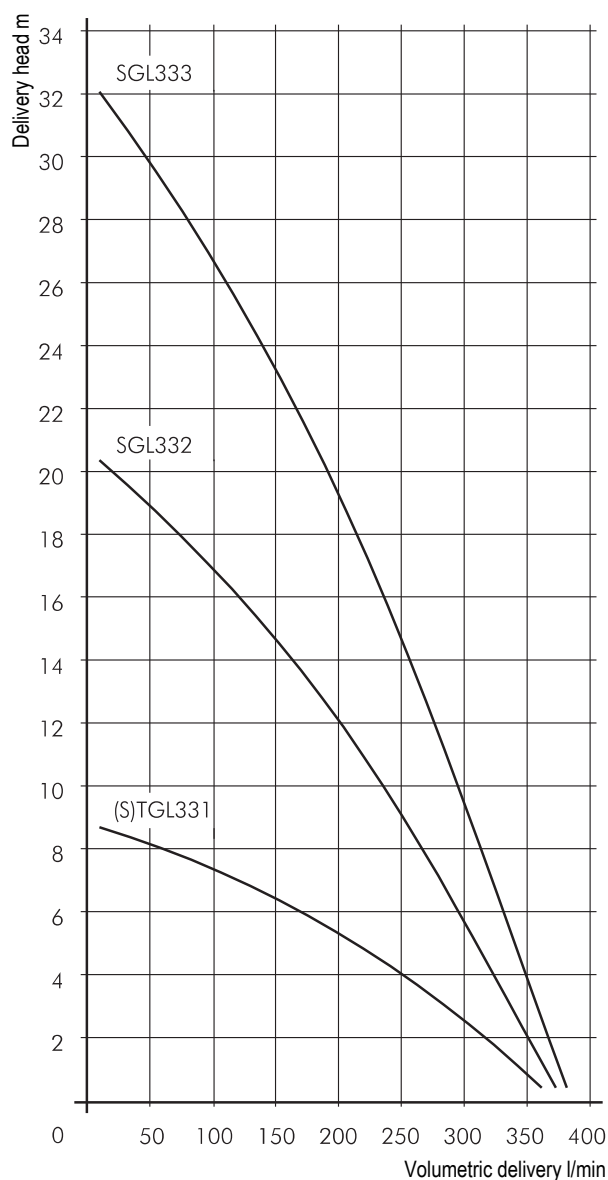

# Quick Suctioning Immersion Pumps

## TGL/SGL501...503

Axial/semi-open impellers

### TGL501

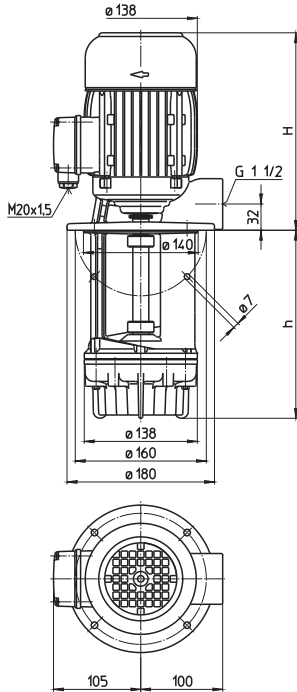

### SGL501...503

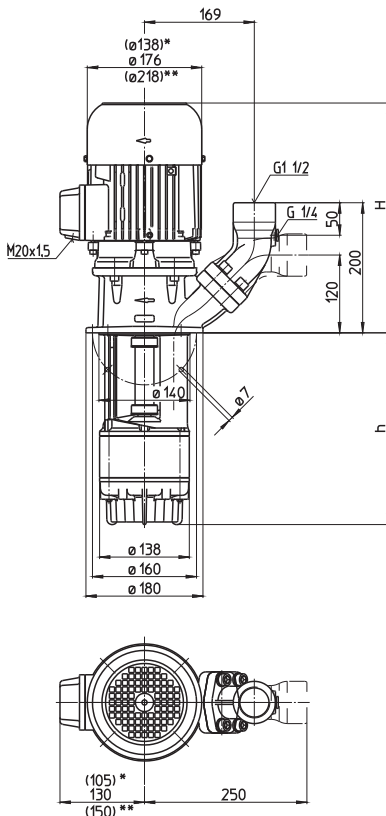

\*) Dimensions for SGL501  
 \*\*) Dimensions for SGL503

Type	Vol. del. at manom. del. head l/min /m	Height H mm	Depth of immersion h mm	Weight kg	Power kW	Voltage 3 ~ V	Fre- quency Hz	Rated current A	Speed 1/min
<b>TGL501/150</b>	250/6	261	150	15.0	1.1	220-240	50	5.0	2700
<b>230</b>			230	16.5					
<b>300</b>			300	17.5					
<b>380</b>			380	18.5					
<b>470</b>			470	19.5					
<b>580</b>			580	20.5					
<b>SGL501/150</b>	250/6	331	150	17	1.1	220-240	50	5.0	2700
<b>230</b>			230	18					
<b>300</b>			300	19					
<b>380</b>			380	20					
<b>470</b>			470	21					
<b>580</b>			580	22					
<b>780</b>			780	25					
<b>930</b>			930	26					
<b>SGL502/220</b>	250/15	395	215	35	2.2	220-240	50	9.2	2850
<b>300</b>			295	36					
<b>370</b>			365	37					
<b>450</b>			445	38					
<b>540</b>			535	39					
<b>650</b>			645	41					
<b>850</b>			845	43					
<b>1000</b>			995	44					
<b>SGL503/280</b>	250/23	445	280	50	3.3	220-240	50	13.8	2900
<b>360</b>			360	51					
<b>430</b>			430	52					
<b>510</b>			510	53					
<b>600</b>			600	54					
<b>710</b>			710	55					
<b>910</b>			910	57					
<b>1060</b>			1060	58					

### Quick Suctioning Immersion Pumps

series **TGL/SGL** equipped with the patented "BRINKMANN's Suction De-aeration System" are excellently suited to pumping **extremely inflated fluids** (grinding oils) as they occur in **high-speed grinding**.

The quick suctioning immersion pumps reach stable working conditions as soon as the liquid level reaches the suction inlet.

The SGL serie offers a **(SAE) flange** with pressure gauge connection port.

The flange can be rotated for either horizontal or vertical pipe connections.

### Applications

- Types of fluid
- water
  - coolants
  - cooling/cutting oils
  - grinding oils
- Kinematic viscosity
- ...90 mm<sup>2</sup>/s (90 cSt)
- Pumping temperature
- 0...80° C

### Construction

- |                 |            |
|-----------------|------------|
| Pump body       | cast iron  |
| Cover           | cast iron  |
| Impeller axial  | cast steel |
| Impeller radial | cast steel |
| Shaft           | steel      |

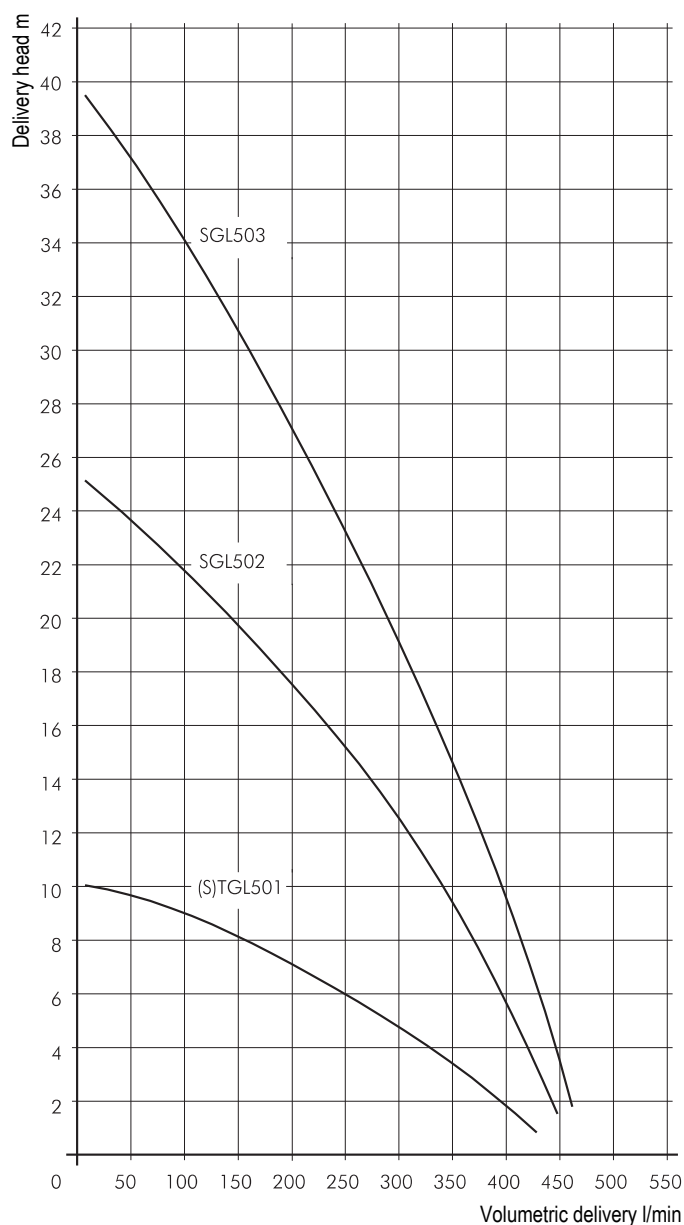

# Quick Suctioning Immersion Pumps

## SGL801...804

Axial/semi-open impellers

### SGL801, 802 SGL803, 804

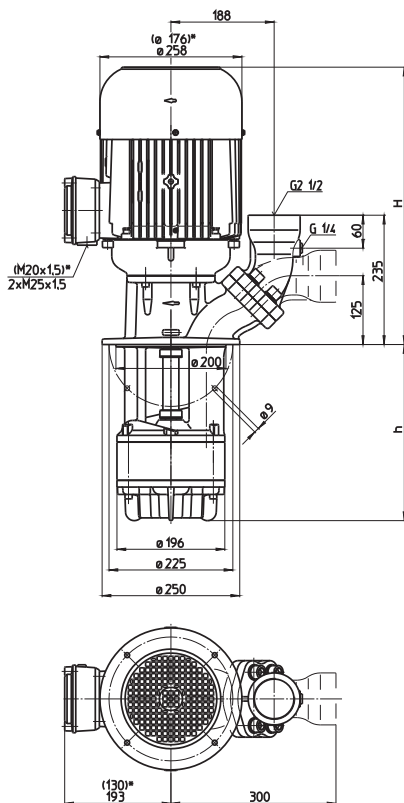

\*) Dimensions for SGL801

Type	Vol. del. at manom. del. head l/min /m	Height H mm	Depth of im- mersion h mm	Weight kg	Power kW	Voltage 3 ~ V	Fre- quency Hz	Rated current A	Speed 1/min
<b>SGL801/220</b>	500/12	429	220	50	2.6	220-240	50	10.9	2850
<b>320</b>			320	52					
<b>450</b>			450	54					
<b>570</b>			570	57					
<b>770</b>			770	62					
<b>1000</b>			1000	69					
<b>SGL802/290</b>	500/25	504	290	83	5.5	220-240	50	22.0	2900
<b>390</b>			390	86					
<b>520</b>			520	90					
<b>640</b>			640	94					
<b>840</b>			840	99					
<b>1070</b>			1070	106					
<b>SGL803/360</b>	500/35	542	360	103	7.5	220-240	50	29	2900
<b>460</b>			460	108					
<b>590</b>			590	112					
<b>710</b>			710	116					
<b>910</b>			910	121					
<b>SGL804/430</b>	500/46	592	430	124	10.0	220-240	50	40	2900
<b>530</b>			530	127					
<b>660</b>			660	131					
<b>780</b>			780	135					
<b>980</b>			980	140					



### Quick Suctioning Immersion Pumps

series SGL equipped with the patented "BRINKMANN's Suction De-aeration System" are excellently suited to pumping **extremely inflated fluids** (grinding oils) as they occur in **high-speed grinding**.

The quick suctioning immersion pumps reach stable working conditions as soon as the liquid level reaches the suction inlet.

The SGL serie offers a **flange** with pressure gauge connection port.

The flange can be rotated for either horizontal or vertical pipe connections.

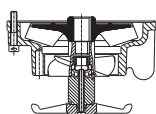

The pump SGL801 is available (upon request) with an additional agitator at the pump suction for breaking up and separating large bundles of chips or birds nests.



### Applications

Types of fluid  
 water  
 coolants  
 cooling/cutting oils  
 grinding oils  
 Kinematic viscosity  
 ...90 mm<sup>2</sup>/s (90 cSt)  
 Pumping temperature  
 0...80° C

### Construction

Pump body	cast iron
Cover	cast iron
Impeller axial	cast steel
Impeller radial	cast steel
Shaft	steel

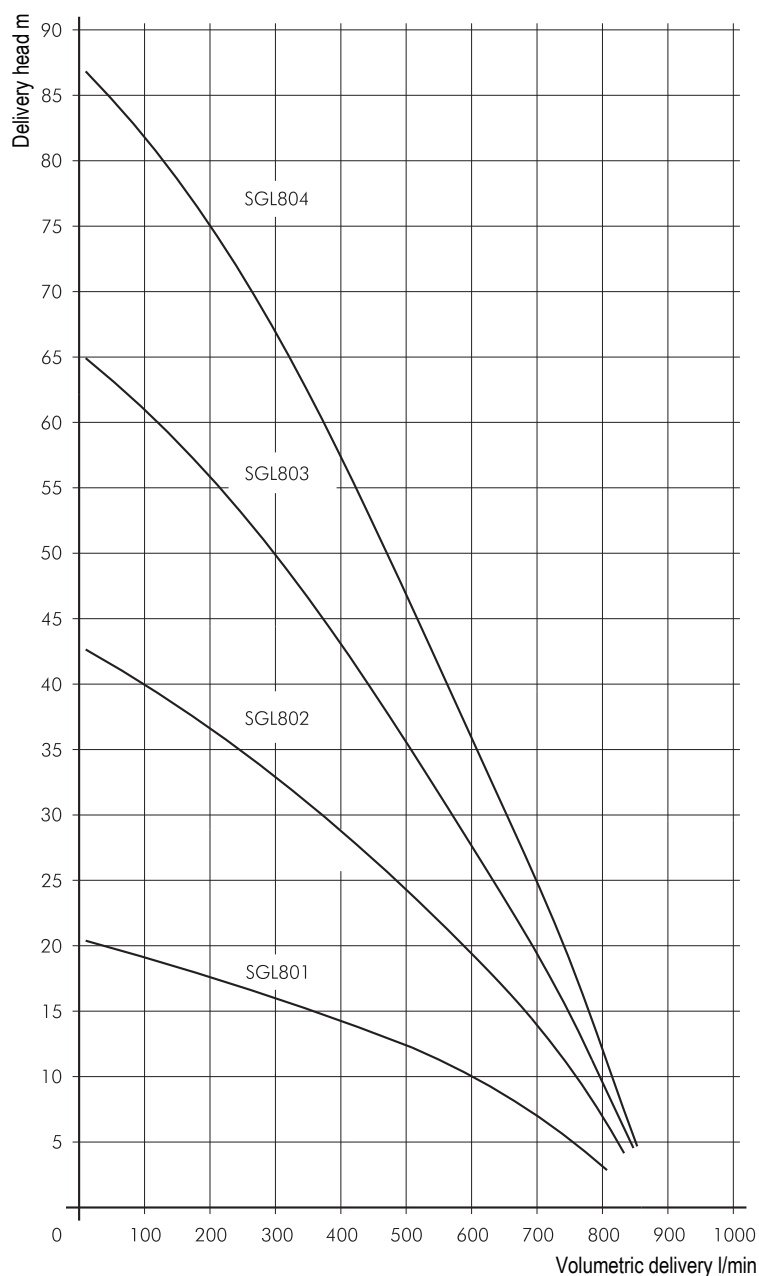

# Quick Suctioning Immersion Pumps

## SGL1101...1103

Axial/semi-open impellers

### SGL1101, 1102 SGL1103

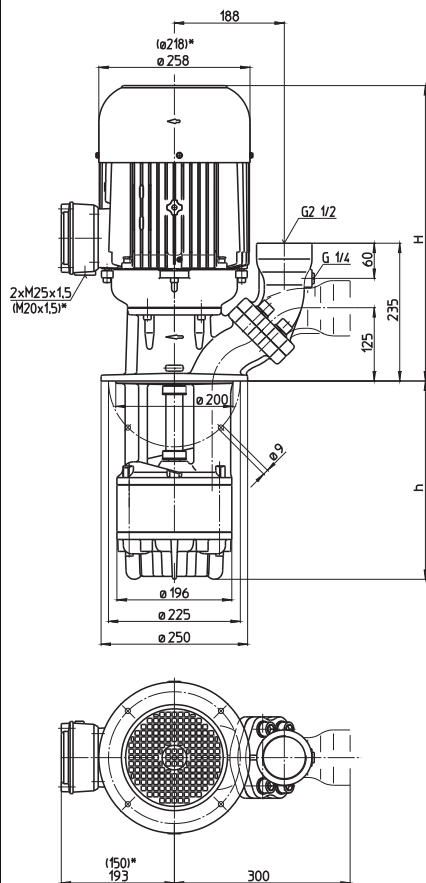

\*) Dimensions for SGL1101

Type	Vol. del. at manom. del. head l/min /m	Height H mm	Depth of im- mersion h mm	Weight kg	Power kW	Voltage 3 ~ V	Fre- quency Hz	Rated current A	Speed 1/min
<b>SGL1101/230</b>	900/10	468	230	58	4.0	220-240	50	16.5	2900
<b>330</b>			330	60					
<b>460</b>			460	62					
<b>580</b>			580	65					
<b>780</b>			780	70					
<b>1010</b>			1010	77					
<b>SGL1102/310</b>	900/21	542	310	96	7.5	220-240	50	29	2900
<b>410</b>			410	99					
<b>540</b>			540	103					
<b>660</b>			660	107					
<b>860</b>			860	112					
<b>1090</b>			1090	119					
<b>SGL1103/390</b>	900/33	592	390	116	10.0	220-240	50	40	2900
<b>490</b>			490	119					
<b>620</b>			620	125					
<b>740</b>			740	127					
<b>940</b>			940	132					

### Quick Suctioning Immersion Pumps

series SGL equipped with the patented "BRINKMANN's Suction De-aeration System" are excellently suited to pumping **extremely inflated fluids** (grinding oils) as they occur in **high-speed grinding**.

The quick suctioning immersion pumps reach stable working conditions as soon as the liquid level reaches the suction inlet.

The SGL serie offers a **flange** with pressure gauge connection port.

The flange can be rotated for either horizontal or vertical pipe connections.

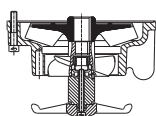

The pump SGL1101 is available (upon request) with an additional agitator at the pump suction for breaking up and separating large bundles of chips or birds nests.

### Applications

Types of fluid  
 water  
 coolants  
 cooling/cutting oils  
 grinding oils  
 Kinematic viscosity  
 ...90 mm<sup>2</sup>/s (90 cSt)  
 Pumping temperature  
 0...80° C

### Construction

Pump body	cast iron
Cover	cast iron
Impeller axial	cast steel
Impeller radial	cast steel
Shaft	steel

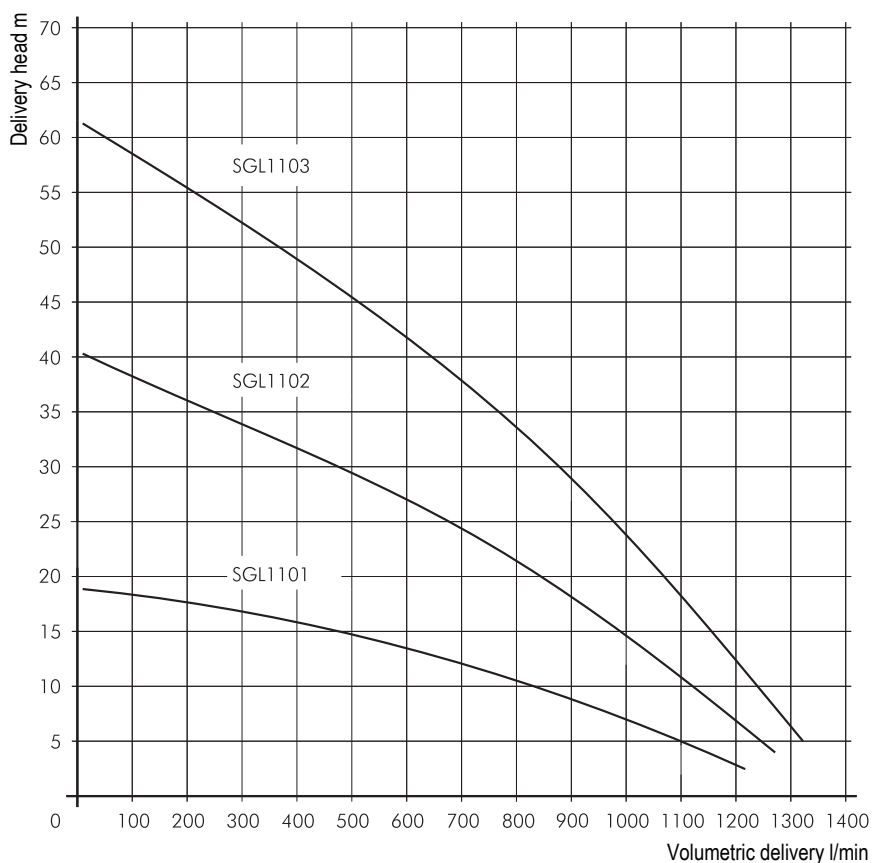

# Quick Suctioning Immersion Pumps



## SGL1400...2200

Axial/semi-open impellers

### SGL1400...1700

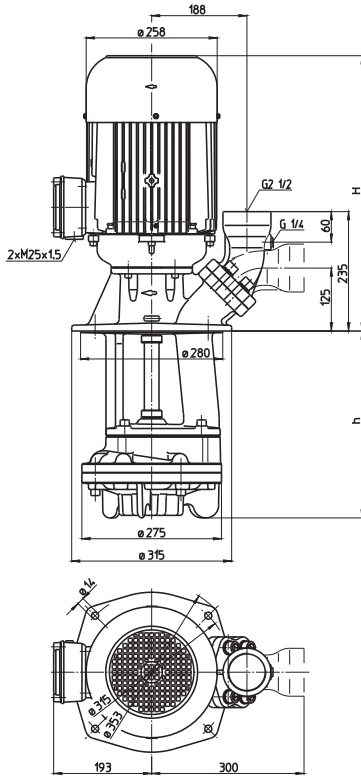

Type	Vol. del. at manom. del. head l/min /m	Height H mm	Depth of immersion h mm	Weight kg	Power kW	Voltage 3 ~ V	Fre- quency Hz	Rated current A	Speed 1/min
<b>SGL1400/310</b>	1200/15	542	310	104	7.5	220-240	50	29	2900
	<b>440</b>		440	106					
	<b>560</b>		560	108					
	<b>810</b>		810	114					
	<b>1060</b>		1060	116					
<b>SGL1700/310</b>	1500/15	592	310	123	10.0	220-240	50	40	2900
	<b>440</b>		440	126					
	<b>560</b>		560	128					
	<b>810</b>		810	134					
	<b>1060</b>		1060	136					
<b>SGL1402/420</b>	1200/35	938	420	182	18.5	400	50	32	2940
	<b>550</b>		550	184					
	<b>670</b>		670	186					
	<b>920</b>		920	192					
	<b>1170</b>		1170	194					
<b>SGL1702/420</b>	1500/42	1022	420	245	22.0	400	50	39	2945
	<b>550</b>		550	249					
	<b>670</b>		670	253					
	<b>920</b>		920	262					
	<b>1170</b>		1170	266					
<b>SGL2200/340</b>	1800/25	938	340	151	18.5	400	50	32	2940
	<b>470</b>		470	153					
	<b>590</b>		590	155					
	<b>840</b>		840	161					
	<b>1090</b>		1090	173					

### SGL1402...2200

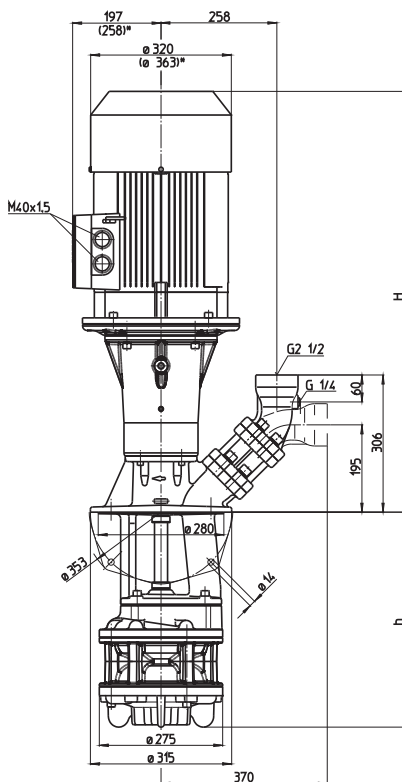

\*) Dimensions for SGL1702

### Quick Suctioning Immersion Pumps

series SGL equipped with the patented "BRINKMANN's Suction De-aeration System" are excellently suited to pumping **extremely inflated fluids** (grinding oils) as they occur in **high-speed grinding**.

The quick suctioning immersion pumps reach stable working conditions as soon as the liquid level reaches the suction inlet.

The SGL serie offers a **flange** with pressure gauge connection port.

The flange can be rotated for either horizontal or vertical pipe connections.

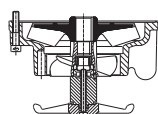

The pumps SGL1400, SGL1700 and SGL2200 are available (upon request) with an additional agitator at the pump suction for breaking up and separating large bundles of chips or birds nests.

### Applications

Types of fluid  
 water  
 coolants  
 cooling/cutting oils  
 grinding oils  
 Kinematic viscosity  
 ...90 mm<sup>2</sup>/s (90 cSt)  
 Pumping temperature  
 0...80° C

### Construction

Pump body	cast iron
Cover	cast iron
Impeller axial	cast steel
Impeller radial	cast steel
Shaft	steel

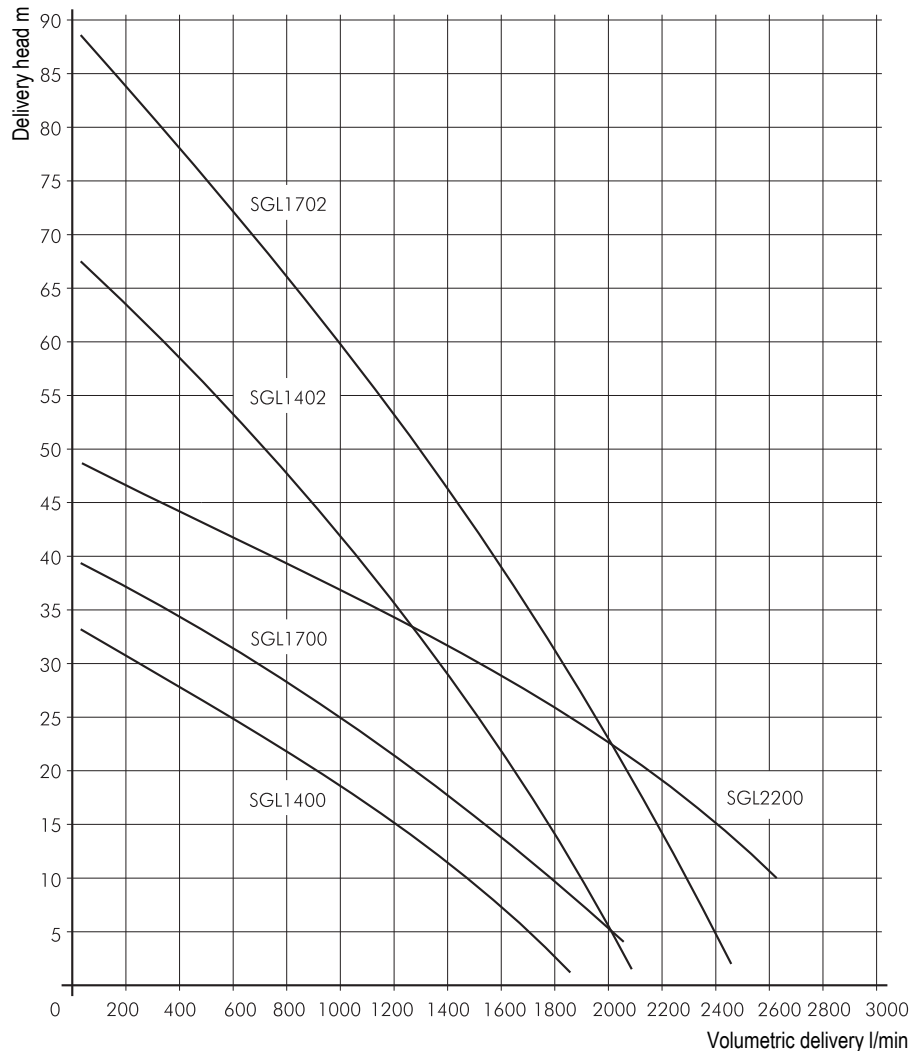

# Quick Suctioning Immersion Pumps

## SFL650...2350

Axial/semi-open impellers

### SFL650, 850 SFL1150

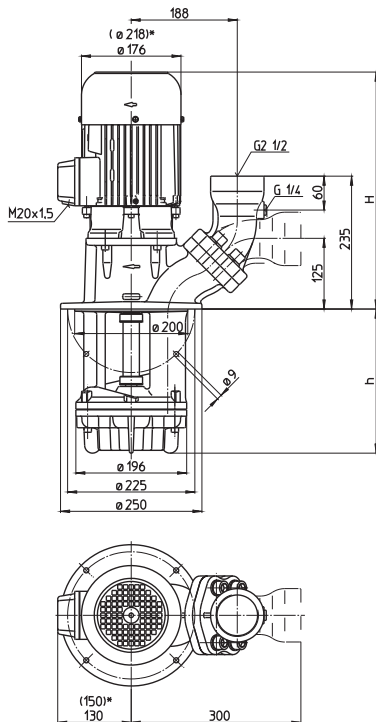

### SFL1350...2350

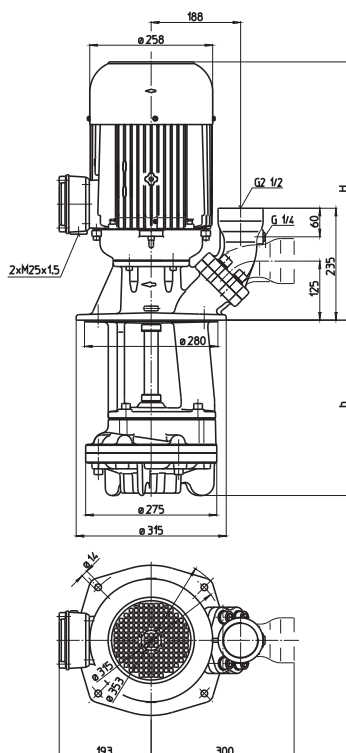

\*) Dimensions for SFL1150  
Dimensions SFL2350 above flange as with  
SGL1402

Type	Vol. del. at manom. del. head l/min / m	Height H mm	Depth of im- mersion h mm	Weight kg	Power kW	Voltage 3 ~ V	Fre- quency Hz	Rated current A	Speed 1/min
<b>SFL650/220</b>	400/8	419	220	49	2.2	220-240	50	9.2	2850
<b>320</b>			320	51					
<b>450</b>			450	53					
<b>570</b>			570	56					
<b>770</b>			770	61					
<b>1000</b>			1000	68					
<b>SFL850/230</b>	500/9	429	230	51	2.6	220-240	50	10.9	2850
<b>330</b>			330	53					
<b>460</b>			460	55					
<b>580</b>			580	58					
<b>780</b>			780	63					
<b>1010</b>			1010	70					
<b>SFL1150/230</b>	600/10	468	230	58	4.0	220-240	50	16.5	2900
<b>330</b>			330	60					
<b>460</b>			460	62					
<b>580</b>			580	65					
<b>780</b>			780	70					
<b>1010</b>			1010	77					
<b>SFL1350/310</b>	700/13	504	310	95	5.5	220-240	50	22.0	2900
<b>440</b>			440	97					
<b>560</b>			560	99					
<b>810</b>			810	107					
<b>1060</b>			1060	110					
<b>SFL1550/310</b>	900/15	542	310	103	7.5	220-240	50	29	2900
<b>440</b>			440	105					
<b>560</b>			560	107					
<b>810</b>			810	113					
<b>1060</b>			1060	115					
<b>SFL1850/310</b>	1150/15	592	310	122	10.0	220-240	50	40	2900
<b>440</b>			440	125					
<b>560</b>			560	127					
<b>810</b>			810	133					
<b>1060</b>			1060	135					
<b>SFL2350/340</b>	1400/28	938	340	150	18.5	400	50	32	2940
<b>470</b>			470	152					
<b>590</b>			590	154					
<b>840</b>			840	170					
<b>1090</b>			1090	172					
					21.3	460	60	31.5	3540

### Quick Suctioning Immersion Pumps

series SFL equipped with the patented "BRINKMANN's Suction De-aeration System" are excellently suited to pumping **extremely inflated fluids** (emulsions) with **heavy chip loads** as they occur in heavy cutting when turning, milling or grinding. The quick suctioning immersion pumps reach stable working conditions as soon as the liquid level reaches the suction inlet.

The SFL serie offers a **flange** with pressure gauge connection port. The flange can be rotated for either horizontal or vertical pipe connections.

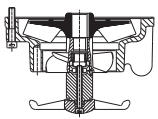

These pumps are available (upon request) with an additional agitator at the pump suction for breaking up and separating large bundles of chips.



### Applications

- Types of fluid
  - water
  - coolants
  - cooling/cutting oils
- Max. chip to coolant ratio by weight: 1.0 %
- Chip material: Aluminium, steel, coloured steels
- Kinematic viscosity ...90 mm<sup>2</sup>/s (90 cSt)
- Pumping temperature 0...80° C

### Construction

- Pump body cast iron
- Cover cast iron
- Impeller axial cast steel
- Impeller radial cast steel
- Shaft steel
- Optional:
- Execution CM1 Impeller radial
- Execution CM3 Cover CrMo-steel
- Impeller axial
- Impeller radial

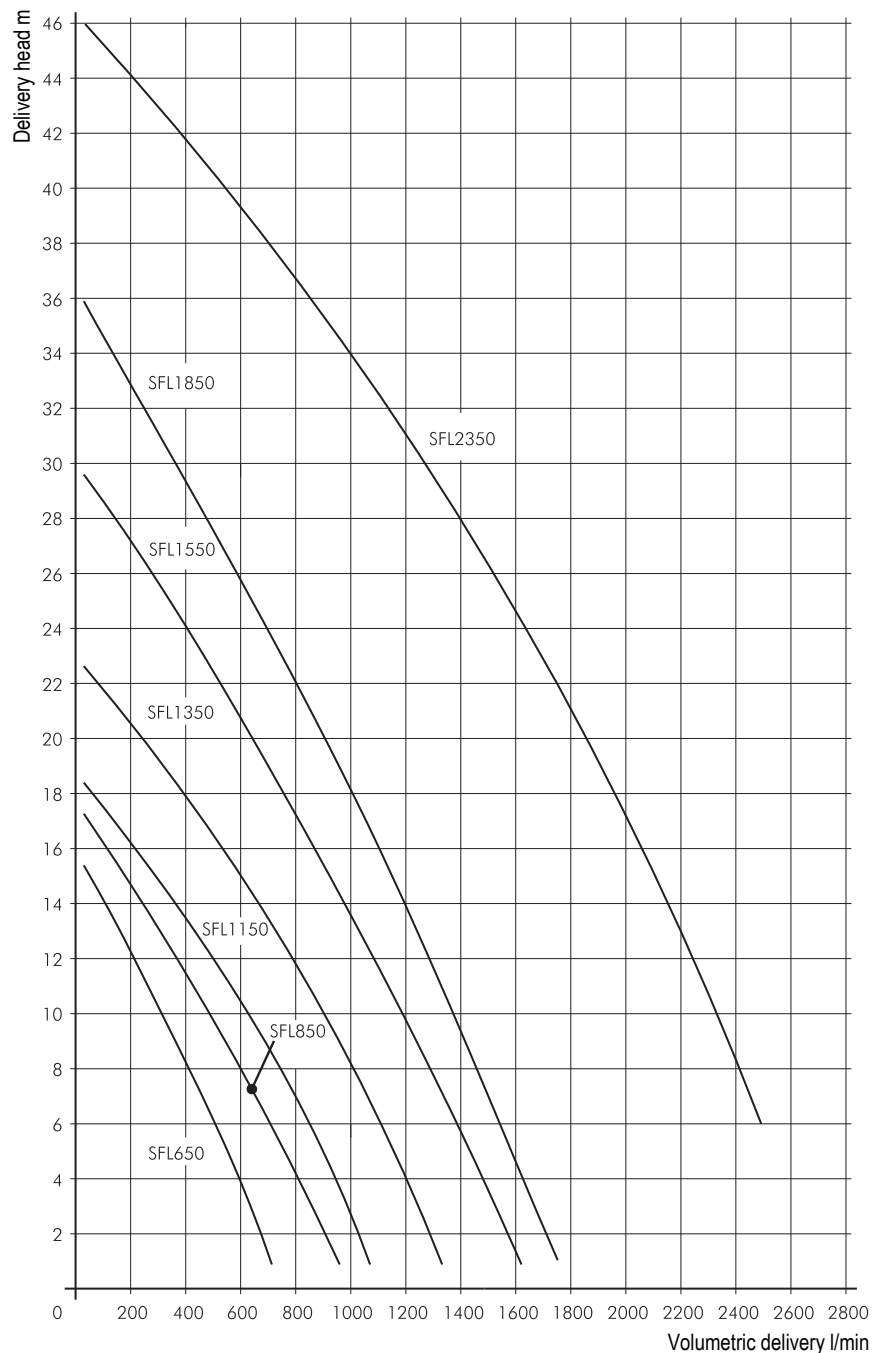

# Cutter Pumps

## SFC820...2320

Axial/semi-open impellers

### SFC820...1120

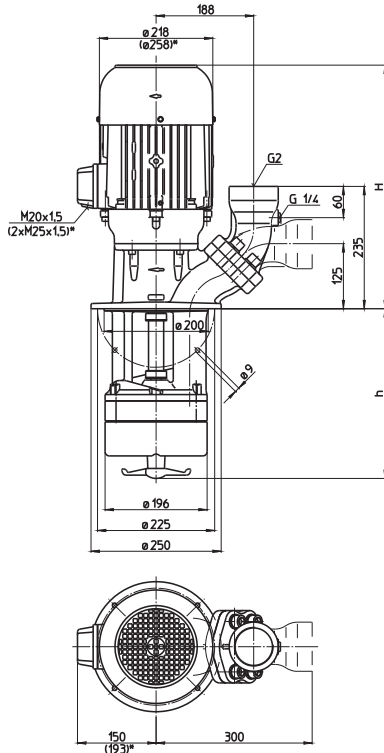

### SFC1520...2320

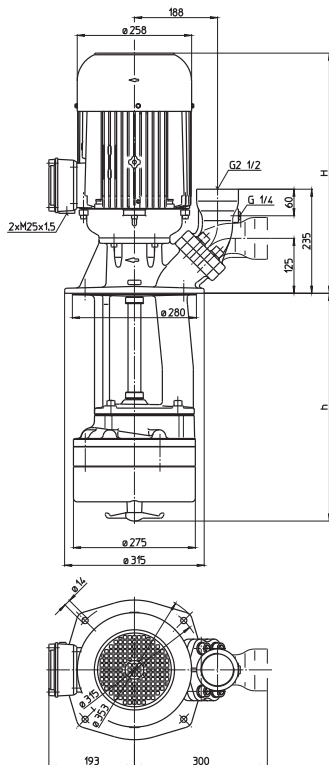

\*) Dimensions for SFC1120  
Dimensions SFC2320 above flange as with SGL1402

Type	Vol. del. at manom. del. head l/min /m	Height H mm	Depth of im- mersion h mm	Weight kg	Power kW	Voltage 3 ~ V	Fre- quency Hz	Rated current A	Speed 1/min
<b>SFC820/290</b>	400/10	487	292	69	4.0	220-240	50	16.5	2900
<b>390</b>			392	71		380-420	50	9.5	2900
<b>520</b>			522	73		460	60	9.5	3450
<b>640</b>			642	76					
<b>SFC1120/290</b>	500/12	504	292	91	5.5	220-240	50	22.0	2900
<b>390</b>			392	93		380-420	50	12.5	2900
<b>520</b>			522	95		460	60	12.5	3450
<b>640</b>			642	98					
<b>SFC1520/370</b>	700/16	542	372	123	7.5	220-240	50	29	2900
<b>500</b>			502	125		380-420	50	17	2900
<b>620</b>			622	127		460	60	17	3450
<b>SFC1820/370</b>	800/20	592	372	142	10.0	220-240	50	40	2900
<b>500</b>			502	145		380-420	50	23	2900
<b>620</b>			622	147		460	60	23	3450
<b>SFC2320/400</b>	900/28	938	400	160	18.5	400	50	32	2940
<b>530</b>			530	163					
<b>650</b>			650	166	21.3	460	60	31.5	3540





### Cutter Pumps

The cutter pumps of the **series SFC** are capable of cutting aluminium chips and similar materials and pumping of these materials along with the coolant fluid. An agitator located at the pump suction helps to break up and separate any large bundles of chips or birds nests which reach the pump suction.

The specially made cutting unit (> 60HRC) is cutting chips and the above located semi-open impeller allows with its large clearances to pump the particles along with the coolant fluid from the machine back to the filter. The SFC pumps are capable of handling chip to coolant ratios of up to 1.5% by weight.

The SFC pumps are equipped with the user-friendly 45 degree **flange** connection which allows for either vertical or horizontal pipe connection and the connection of a pressure gauge with G 1/4.

For more information see mechanical features within the technical information section.



### Applications

- Types of fluid
  - water
  - coolants
  - cooling/cutting oils
- Max. chip to coolant ratio by weight: 1.5 %
- Chip material: Aluminium
- Chip geometry: Chip bundles
- Kinematic viscosity ...90 mm<sup>2</sup>/s (90 cSt)
- Pumping temperature 0...80° C

### Construction

- |                 |                      |
|-----------------|----------------------|
| Pump body       | cast iron            |
| Cover           | cast iron            |
| Impeller radial | cast steel           |
| Cutting unit    | Hardened (>60 HRC)   |
| Agitator        | Highly ductile steel |
| Shaft           | steel                |

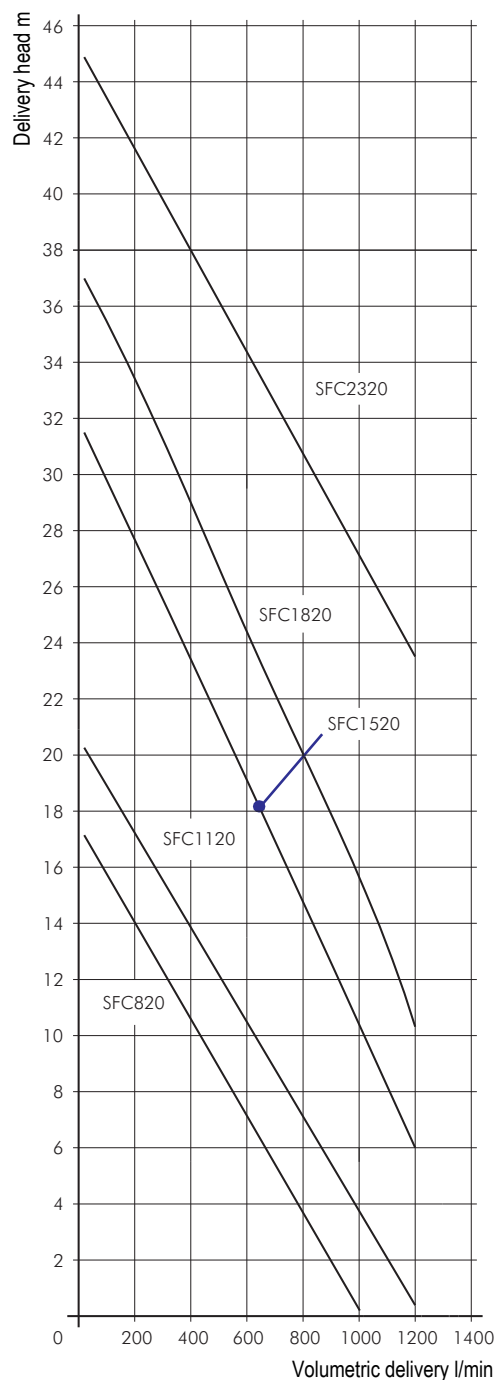

# Free Flow-Immersion Pumps

## FT35...FTA140

### Semi-open impellers

#### FT35

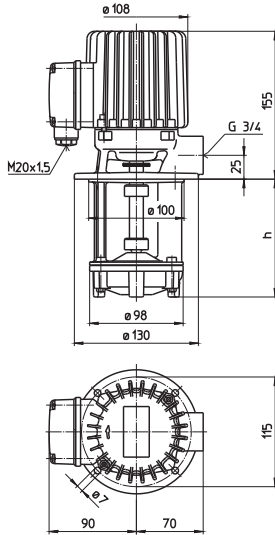

#### FTA140

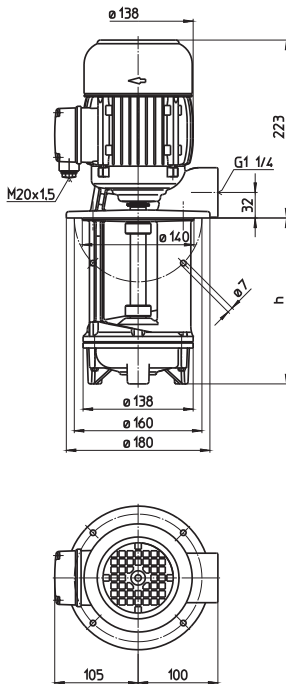

Type	Vol. del. at manom. del. head l/min / m	Height H mm	Depth of immersion h mm	Weight kg	Power kW	Voltage 3 ~ V	Fre- quency Hz	Rated current A	Speed 1/min
<b>FT35/100</b>	40/2	155	100	5.2	0.21	220-240	50	0.71	2800
<b>130</b>			130	5.5		380-420	50	0.41	2800
<b>180</b>			180	5.9		460	60	0.41	3300
<b>230</b>			230	6.2					
<b>280</b>			280	6.5					
<b>360</b>			360	7.3					
<b>FTA140/130</b>	150/2	223	130	13.5	0.55	220-240	50	2.50	2750
<b>210</b>			210	14.0		380-420	50	1.45	2750
<b>280</b>			280	14.5		460	60	1.45	3250
<b>360</b>			360	15.0					
<b>450</b>			450	17.0					
<b>560</b>			560	18.5					



### Free Flow-Immersion Pumps

series FT/FTA are provided to lift coolant for filtering.

Coarse shreds can be transported together with liquids.

The pump inlet and pump discharge port have the same dimensions.

### Applications

Types of fluid  
 water  
 coolants  
 cooling/cutting oils  
 Kinematic viscosity  
 ...90 mm<sup>2</sup>/s (90 cSt)  
 Pumping temperature  
 0...60° C

### Construction

Pump body	cast iron
Cover	cast iron
Impeller	brass
Shaft	steel
Optional:	
Cover	POM (FT35)
Impeller	POM
	cast iron
Noise level	
FT35	45 dBA
FTA140	60 dBA

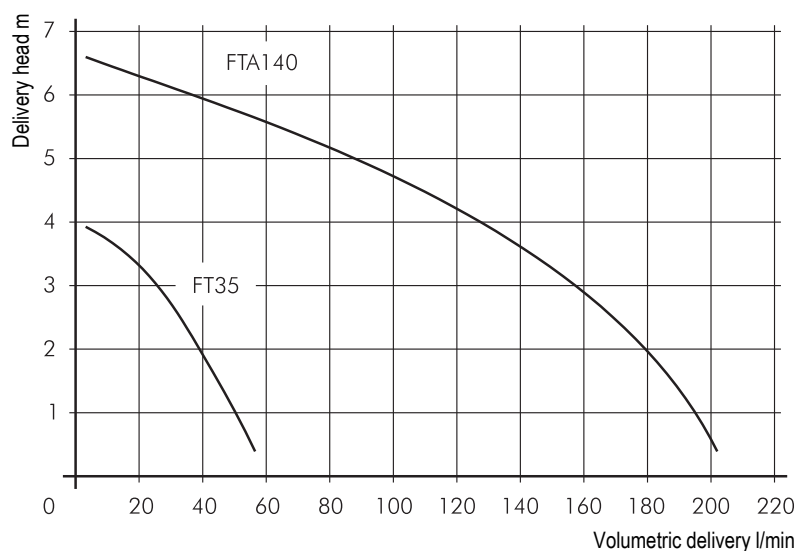

# Free Flow-Immersion Pumps



## SFT450...1400

Semi-open impellers

### SFT450...1100

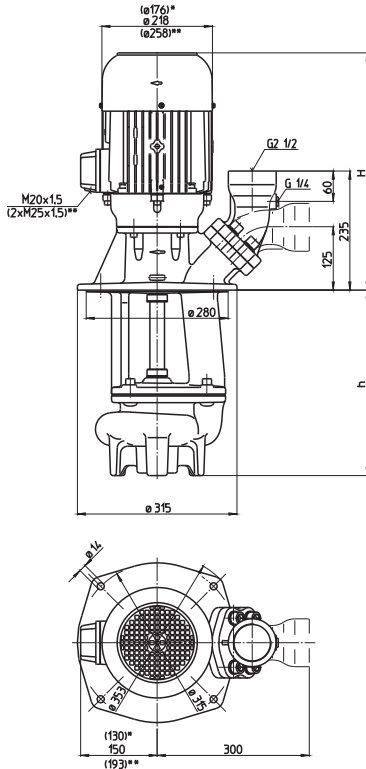

### SFT1300...1400

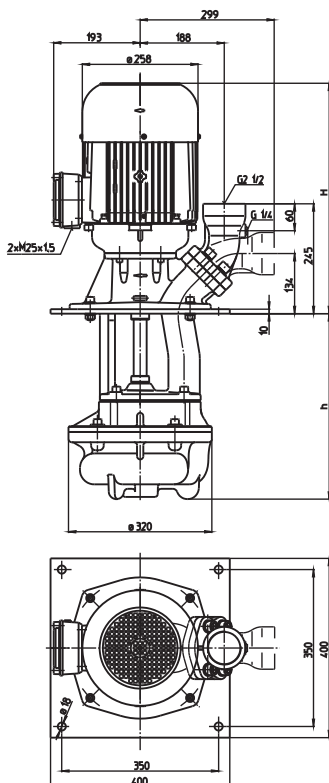

\*) Dimensions for SFT450  
 \*\*) Dimensions for SFT1100

Type	Vol. del. at manom. del. head l/min / m	Height H mm	Depth of immersion h mm	Weight kg	Power kW	Voltage 3 ~ V	Fre- quency Hz	Rated current A	Speed 1/min
<b>SFT450/300</b>	600/5	419	300	71	2.2	220-240	50	9.2	2850
<b>430</b>			430	74					
<b>550</b>			550	76					
<b>800</b>			800	94					
<b>1050</b>			1050	99					
<b>SFT710/300</b>	800/5	468	300	78	3.3	220-240	50	13.8	2900
<b>430</b>			430	81					
<b>550</b>			550	83					
<b>800</b>			800	101					
<b>1050</b>			1050	106					
<b>SFT1100/300</b>	1100/5	504	300	91	5.5	220-240	50	22.0	2900
<b>430</b>			430	94					
<b>550</b>			550	96					
<b>800</b>			800	115					
<b>1050</b>			1050	121					
<b>SFT1300/360</b>	800/11	514	363	142	5.5	220-240	50	22.0	2900
<b>490</b>			493	147					
<b>610</b>			613	151					
<b>SFT1350/360</b>	800/15	542	363	150	7.5	220-240	50	29	2900
<b>490</b>			493	155					
<b>610</b>			613	159					
<b>SFT1400/360</b>	800/19	592	363	167	10.0	220-240	50	40	2900
<b>490</b>			493	172					
<b>610</b>			613	176					

### Free Flow-Immersion Pumps

series SFT are designed to lift coolant for filtering. **Coarse shreds** can be transported together with liquids.

**The pump inlet and pump discharge port have the same dimensions.**

The SFT serie offers a **flange** with pressure gauge connection port.

The flange can be rotated for either horizontal or vertical pipe connections.

### Applications

Types of fluid  
coolants

Max. chip to coolant ratio by weight:  
1.5 %

Chip material:  
Aluminium, steel, coloured steels

Chip geometry:  
Flow chips up until 80 mm long

Kinematic viscosity  
...30 mm<sup>2</sup>/s (30 cSt)

On request  
higher viscosity

Pumping temperature  
0...60° C

### Construction

Pump body	cast iron
Cover	special cast iron
Impeller	cast steel
Shaft	steel

Optional:  
-CL with axial impeller cast steel  
for lower liquid level

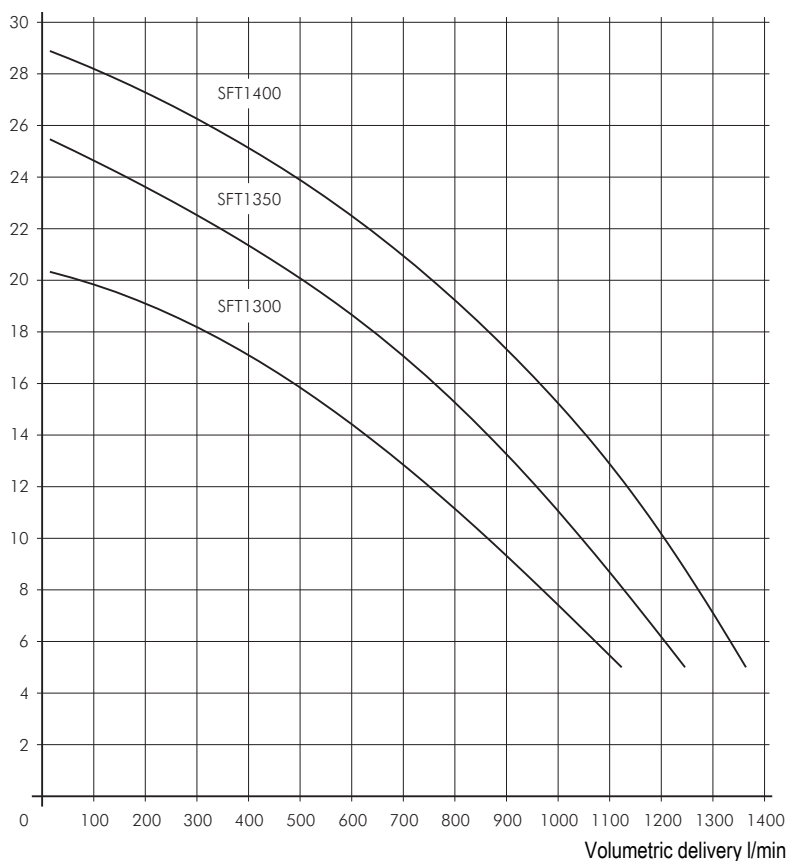
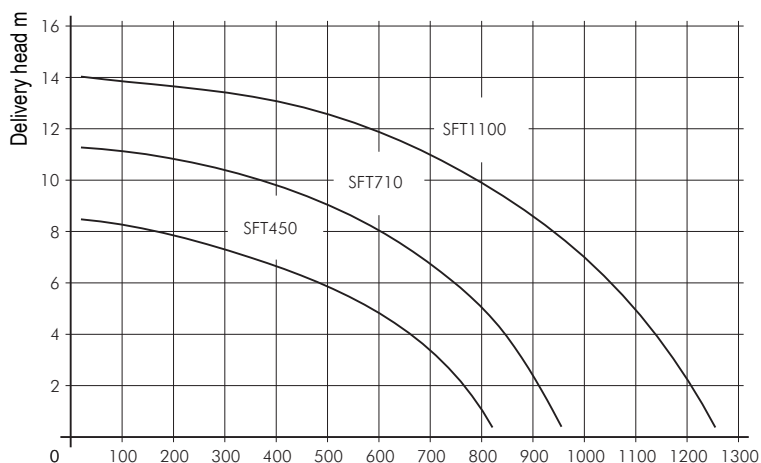

# Free Flow-Immersion Pumps



## SFT1554...3554

Semi-open impellers

### SFT1554-C

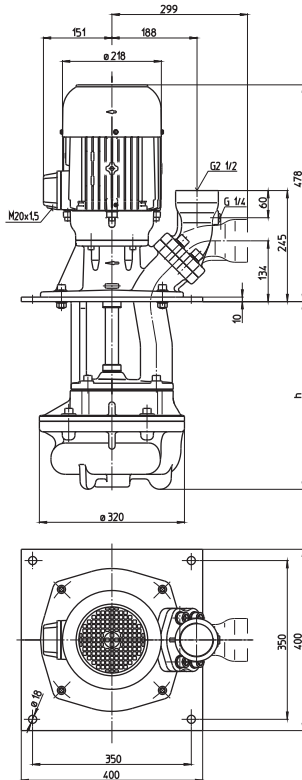

Type	Vol. del. at manom. del. head l/min /m	Height H mm	Depth of immersion h mm	Weight kg	Power (4-pole) kW	Voltage 3~ V	Frequency Hz	Rated current A	Speed 1/min
<b>SFT1554/360-C</b>	600/10	478	363	109	3.0	400	50	6.3	1450
<b>490-C</b>			493	113		460	60	6.3	1750
<b>SFT2254/460</b>	1100/12	701	460	203	7.5	400	50	14.5	1455
<b>660</b>			660	213		460	60	12.8	1760
<b>860</b>			860	223					
<b>1210</b>			1210	278					
<b>1610</b>			1610	298					
<b>SFT3054/460</b>	1600/12	938	460	224	11.0	400	50	21.0	1460
<b>660</b>			660	234		460	60	18.2	1765
<b>860</b>			860	244					
<b>1210</b>			1210	299					
<b>1610</b>			1610	319					
<b>SFT3554/460</b>	2100/12	978	460	250	15.0	400	50	28.0	1460
<b>660</b>			660	260		460	60	24.5	1765
<b>860</b>			860	270					
<b>1210</b>			1210	325					
<b>1610</b>			1610	345					

### SFT2254...3554

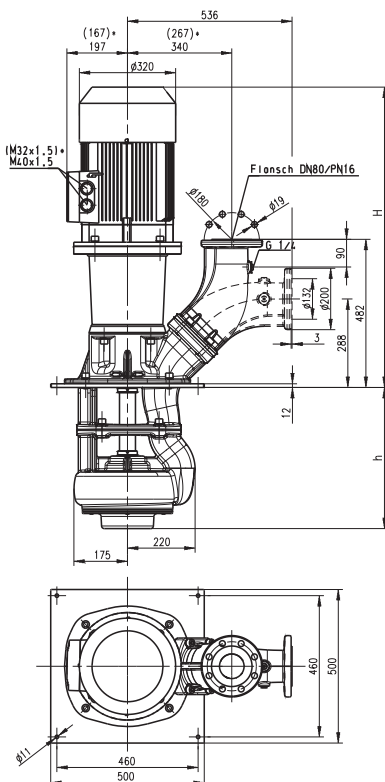

\*) Dimensions for SFT2254

### Free Flow-Immersion Pumps

series SFT are designed to lift coolant for filtering. **Coarse shreds** can be transported together with liquids.

#### Half speed.

The SFT serie offers a **flange** with pressure gauge connection port.

The flange can be rotated for either horizontal or vertical pipe connections.

### Applications

Types of fluid  
coolants

Max. chip to coolant ratio by weight:  
1.5 %

Chip material:

Aluminium, steel, coloured steels

Chip geometry:

Flow chips up until 80 mm long

The max. ball diameter is 45 mm

Kinematic viscosity

...12 mm<sup>2</sup>/s (12 cSt)

Pumping temperature

0...60° C

### Construction

Pump body

cast iron

Cover

cast iron

Impeller

cast steel

Shaft

steel

Optional:

Impeller

CrMo-steel

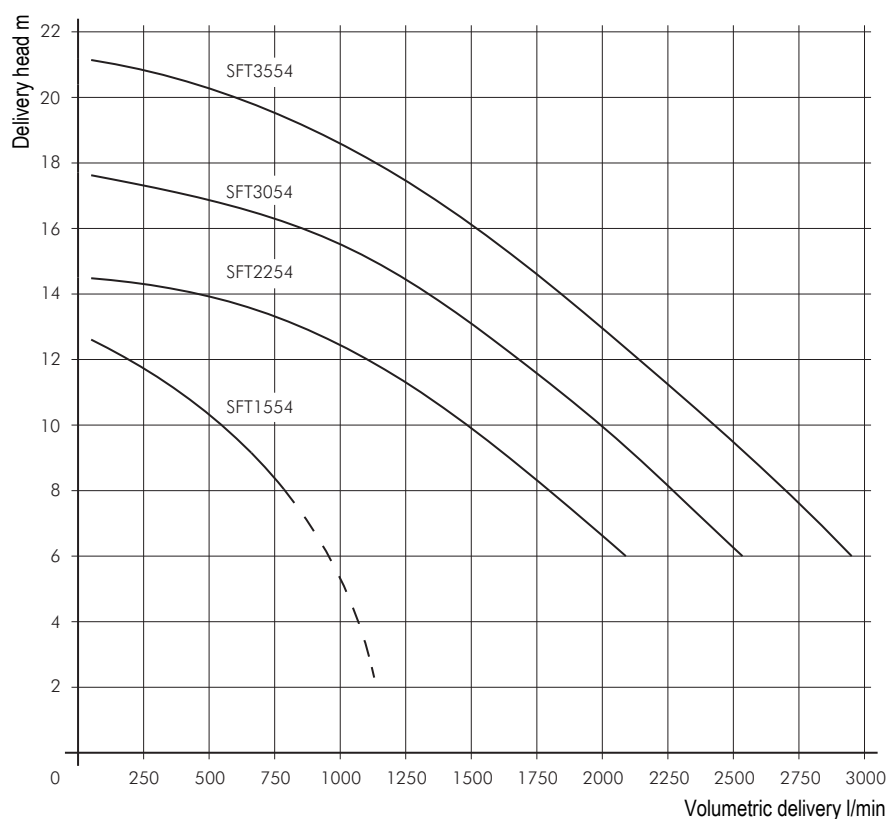

# Suction Immersion Pumps

## TAS/STS301...1001

Axial/semi-open impellers

### TAS301, 401 TAS601

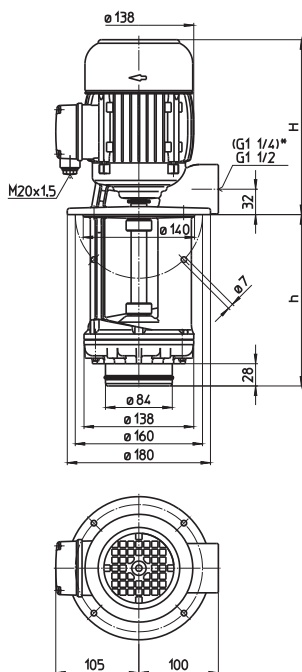

Type	Vol. del. at manom. del. head l/min / m	Height H mm	Depth of immersion h mm	Weight kg	Power kW	Voltage 3 ~ V	Fre- quency Hz	Rated current A	Speed 1/min
<b>TAS301/140</b>	200/5	223	136	12.5	0.55	220-240	50	2.50	2750
<b>220</b>			216	13.0		380-420	50	1.45	2750
<b>290</b>			286	13.5		460	60	1.45	3250
<b>370</b>			366	14.0					
<b>460</b>			456	16.0					
<b>570</b>			566	17.5					
<b>TAS401/140</b>	250/5	241	136	13.5	0.85	220-240	50	4.3	2800
<b>220</b>			216	14.5		380-420	50	2.5	2800
<b>290</b>			286	15.5		460	60	2.5	3300
<b>370</b>			366	16.5					
<b>460</b>			456	17.5					
<b>570</b>			566	18.5					
<b>TAS601/150</b>	400/4	241	144	14.0	0.92	220-240	50	4.7	2700
<b>230</b>			224	15.5		380-420	50	2.7	2700
<b>300</b>			294	16.5		460	60	2.7	3300
<b>380</b>			374	17.5					
<b>470</b>			464	18.5					
<b>580</b>			574	19.5					
<b>STS1001/230</b>	600/14	429	216	51	2.6	220-240	50	10.9	2850
<b>330</b>			316	53		380-420	50	6.3	2850
<b>460</b>			446	55		460	60	6.3	3400
<b>580</b>			566	58					
<b>780</b>			766	63					
<b>1010</b>			996	70					

### STS1001

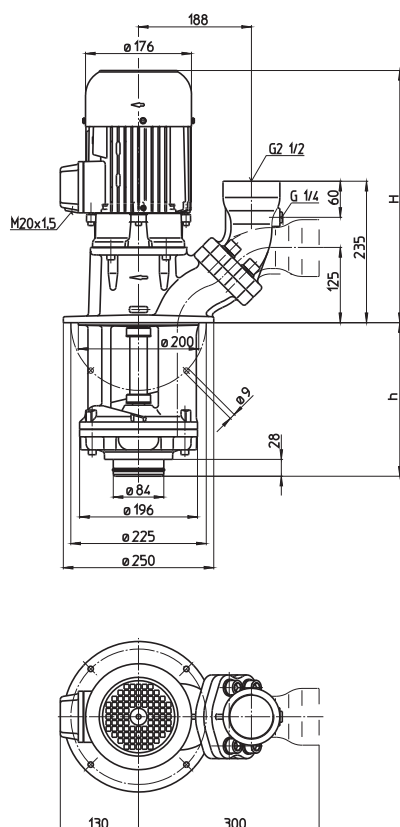

\*) Dimensions for TAS301



### Suction Immersion Pumps

series **TAS/STS** make it possible to **connect to vacuum filters** through their simple connection on the suction side (for instance, with a slot screen).

Suction immersion pumps without seals are positioned in the area of unfiltered coolant in the tank.

With their robust design, they allow operating pressures of - 0.3 bar to - 0.5 bar on the suction side.

The STS serie offers a **flange** with pressure gauge connection port.

The flange can be rotated for either horizontal or vertical pipe connections.



All types specified are also available as multistage pumps e.g. STS304/610. See series TA/STA.

### Applications

Types of fluid

- water
- coolants
- cooling/cutting oils

Kinematic viscosity

...45 mm<sup>2</sup>/s (45 cSt)

Pumping temperature

0...60° C

### Construction

Pump body	cast iron
Cover	cast iron
Impeller axial	cast steel
Impeller radial	brass
Shaft	cast steel (STS1001)
Optional: Impeller radial	cast steel (TAS301...TAS601)

Noise level

TAS301	60 dBA
TAS401...TAS601	62 dBA
STS1001	63 dBA

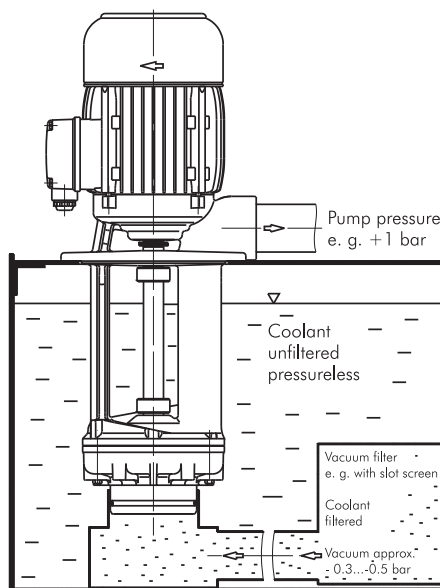

### Suction connection

Intake cover cast iron  
with O-Ring 78 x 4 mm Viton

for  
Connecting pipe  
86,0...86,8 mm inner-Ø

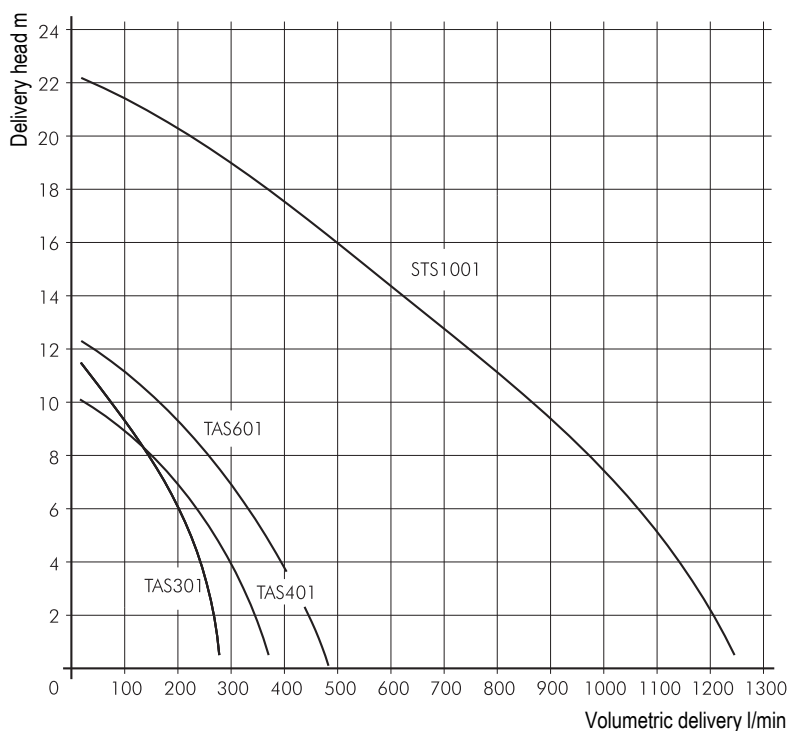

# Lifting Pumps

## TAA70...280

### Axial impellers

#### TAA70

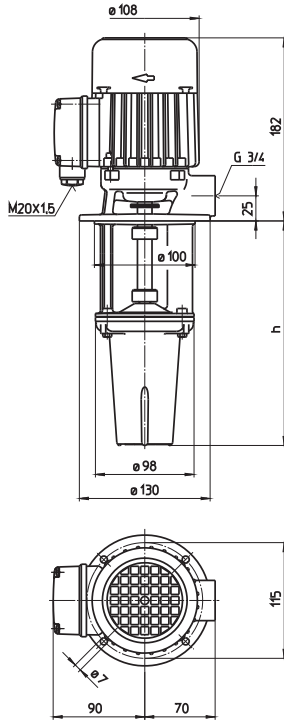

#### TAA140, 280

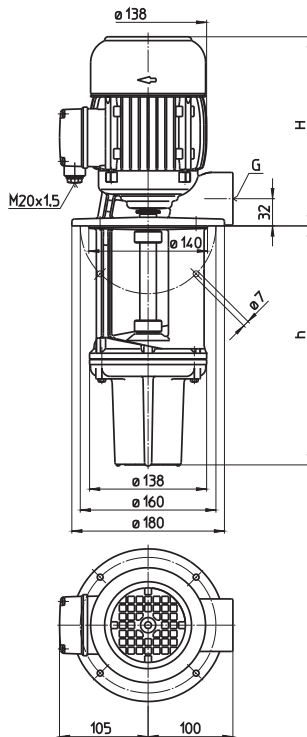

Type	Vol. del. at manom. del. head l/min /m	Height H mm	Depth of immersion h mm	Pipe connection G	Weight kg	Power kW	Voltage 3~ V	Fre- quency Hz	Rated current A	Speed 1/min
<b>TAA70/200</b>	90/2	182	200	G 3/4	8.5	0.22	220-240	50	0.95	2700
<b>230</b>			230		9.0		380-420	50	0.55	2700
<b>280</b>			280		9.5		460	60	0.55	3200
<b>330</b>			330		10.0					
<b>TAA140/200</b>	180/2	223	200	G 1 1/4	14	0.42	220-240	50	1.4	2800
<b>280</b>			280		15		380-420	50	0.8	2800
<b>350</b>			350		16		460	60	0.8	3300
<b>TAA280/200</b>	360/2	241	200	G 1 1/2	16	0.92	220-240	50	4.7	2700
<b>280</b>			280		17		380-420	50	2.7	2700
<b>350</b>			350		18		460	60	2.7	3300

### Lifting Pumps

**series TAA** gently pump **foam-sensitive cooling** lubricants (emulsions or cooling and cutting oils) or highly inflated cooling lubricants such as occur with a high degree of machining in lathing, milling or grinding.

### Applications

Types of fluid  
 coolants  
 cooling/cutting oils  
 Kinematic viscosity  
 ...90 mm<sup>2</sup>/s (90 cSt)  
 Pumping temperature  
 0...60° C

### Construction

Pump body	cast iron
Cover	cast iron
Impellers	cast iron
Shaft	steel
Noise level	
TAA70	57 dBA
TAA140...TAA280	62 dBA

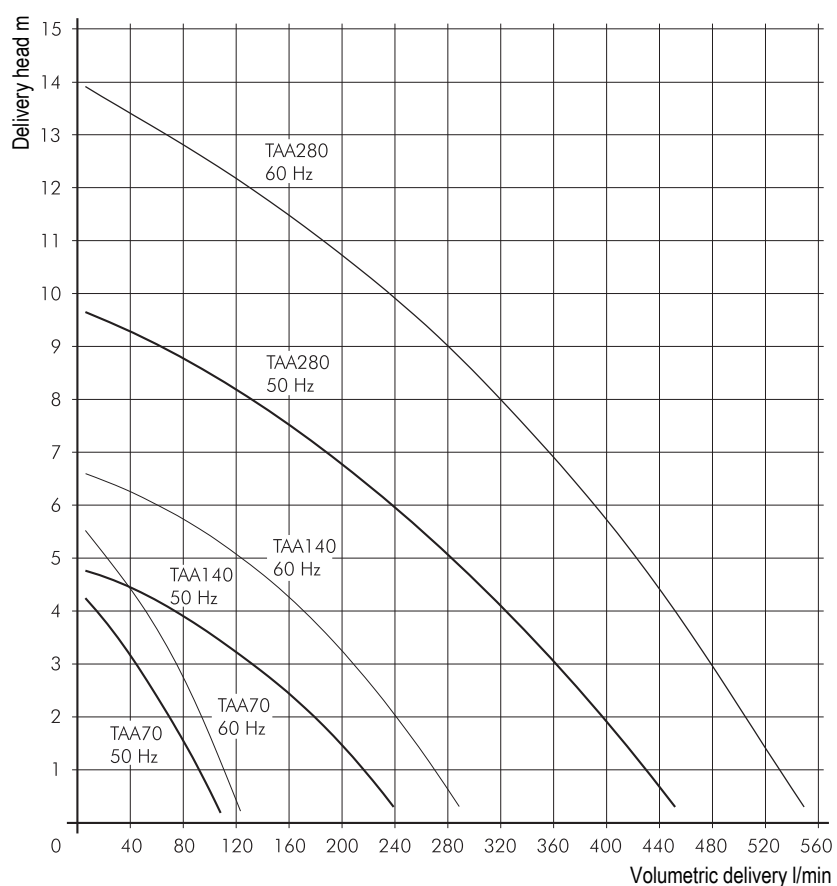

# Horizontal End Suction Pumps

## BAL/SBA, BGL/SBG, BFL/SBF

### Axial/semi-open impellers

#### Horizontal End Suction Pumps

Horizontal End-Suction Pumps are centrifugal inline pumps with a compact design where the impeller is mounted onto the extended motor shaft. These pumps are not self-priming and must be gravity fed.

All horizontal end-suction pumps are equipped with an axial impeller in order to minimize the risk of cavitation. All pumps are equipped with a single mechanical seal.

These pumps are for horizontal installations next to or underneath a tank and they are designed to handle water-soluble coolants as well as cutting oils.

Series SBA, SBG and SBF are equipped with an SAE/45 degree flange and G 1¼ discharge port, which can conveniently be rotated for either horizontal or vertical piping installations.



**BAL, BGL, BFL**



**SBA, SBG, SBF**

#### Application

These pumps are comparable with the vertical immersion pumps of series SAL, SGL and SFL. For a comparison please refer to page 14.

Application			Style	Discharge port
emulsion / air	oil / air	emulsion / oil chips		
<b>SAL</b>	<b>SGL</b>	<b>SFL</b>	immersed	SAE / 45 degree flange
<b>SBA</b>	<b>SBG</b>	<b>SBF</b>	foot mounted	SAE / 45 degree flange
<b>BAL</b>	<b>BGL</b>	<b>BFL</b>	foot mounted	Standard discharge port

#### Dry-running Version (-GD)

Upon request a second mechanical seal is available to allow for dry-running. By utilizing an additional oil reservoir, continuous lubrication of the mechanical seal can be assured, which in turn allows dry-running of the pump. The oil level within the reservoir can be monitored through an integrated monitoring window.

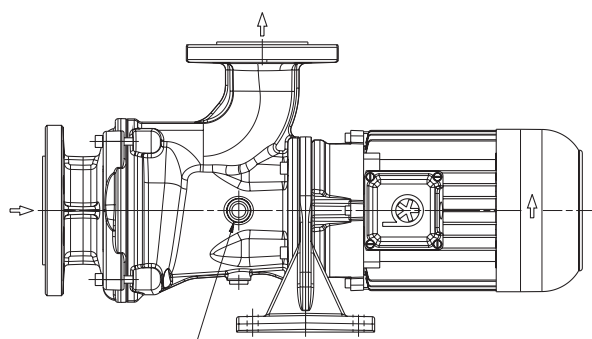

Monitoring window for models with second mechanical seal (-GD)

#### Vertical End Suction Pump (SBG-V)

End suction pump series SBG801 - SBG1700 are available in a vertical mounted design upon request.

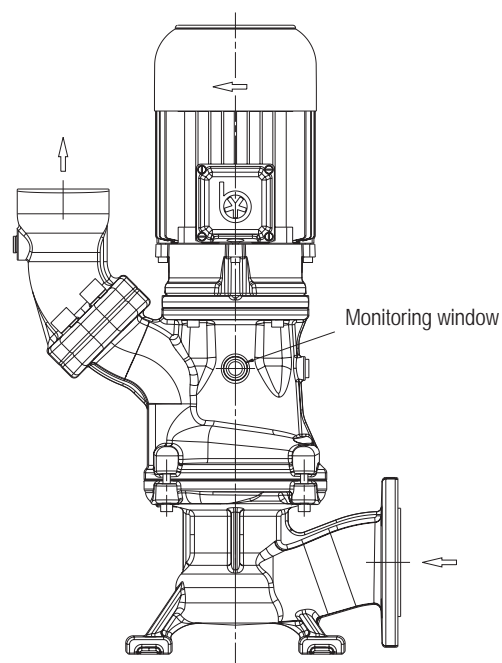

# Horizontal End Suction Pumps

## BAL/SBA, BGL/SBG, BFL/SBF

Axial/semi-open impellers

### Terminal box and foot location

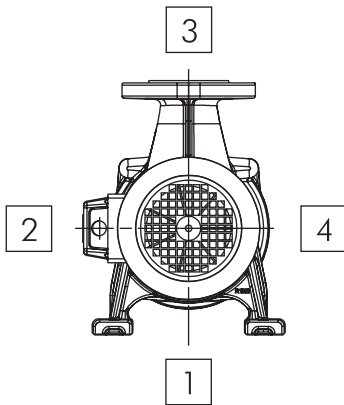

Location	Series BAL, BGL and BFL		Series SBA, SBG and SBF	
	Terminal box location	Foot location	Terminal box location	Foot location
1	–	Standard	–	Standard
2	Standard	●	Standard	●
3	●	–	□	–
4	●	●	●	●

- available
- available upon request
- not available

**Attention:**

Terminal box location and foot location cannot be facing in the same direction!

### Discharge port / suction port

#### 1. Discharge port

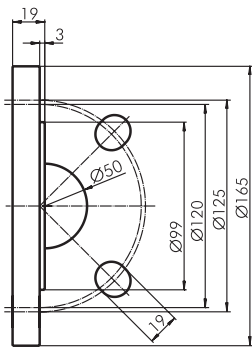

DN50  
for series BAL, BGL and BFL

#### 2. Suction port

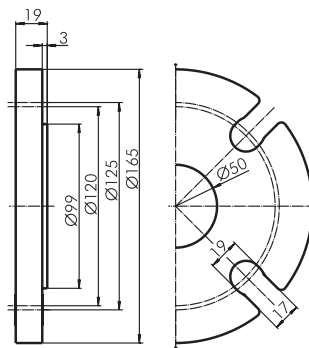

DN50, 4 hole flange connection  
size 140

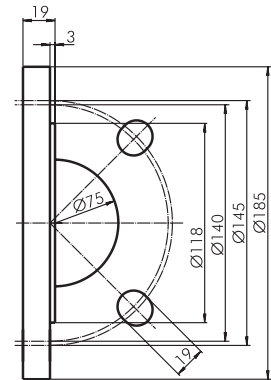

DN65, 4 hole flange connection  
sizes 400, 550, 600  
sizes 650, 850, 1150, 800, 900, 1300

**For series SBA, SBG and SBF featuring the SAE or 45 degree flange please refer to page 17.**

DN50, 4 hole flange connection, is equivalent to ASME B16.1-2005 Class 25 Flange NPS 2 and JIS B 2239:2004 10K A50

DN65, 4 hole flange connection, is equivalent to ASME B16.1-2005 Class 25 Flange NPS 2 1/2 and JIS B 2239:2004 10K A65

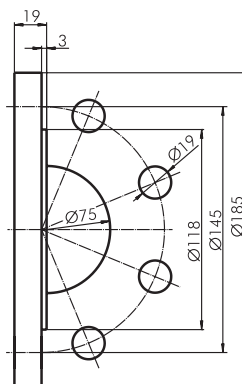

DN65, 8 hole flange connection  
sizes 850, 1150, 1100, 1300  
**Available upon request**

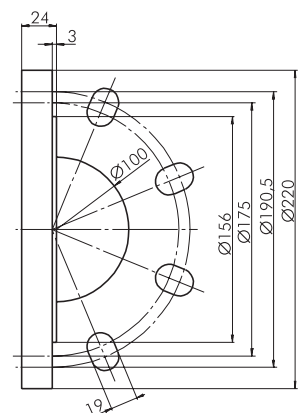

DN100, 8 hole flange connection  
sizes 1350, 1550, 1850  
sizes 1600, 1700, 2000



# Horizontal End-Suction Pumps

## SBA141...143

Axial/semi-open impellers

### SBA141...143

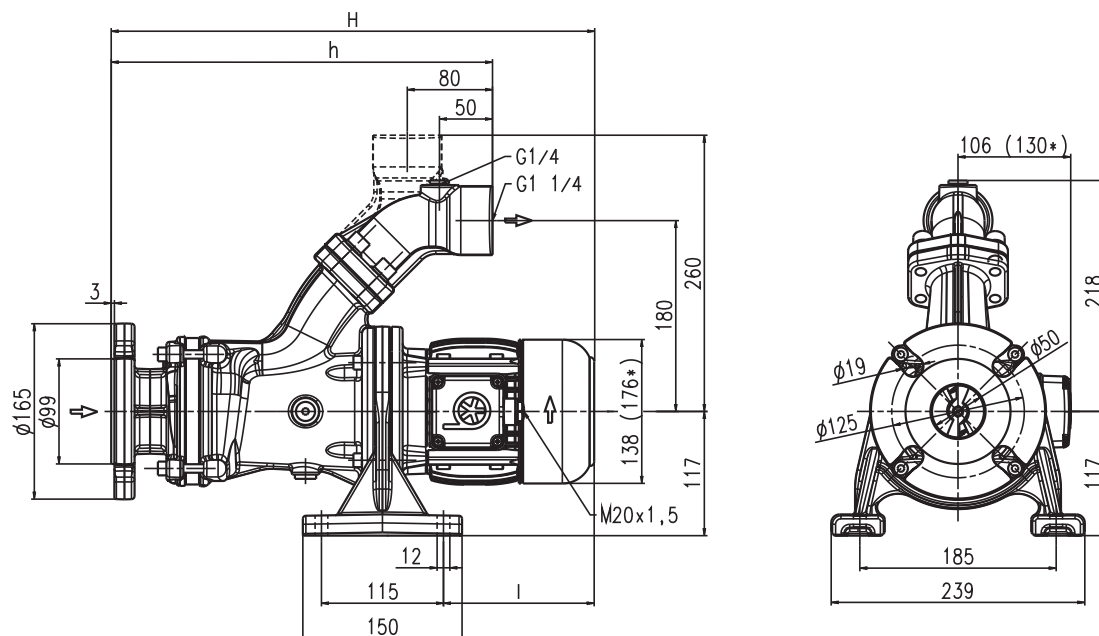

\*) Dimensions for SBA143



Type	Vol. del. at manom. del. head l/min /m	Dimensions		Length l mm	Weight kg	Power kW	Voltage 3 ~ V	Fre- quency Hz	Rated current A	Speed 1/min
		H mm	h mm							
<b>SBA141</b>	100/8	456	359	143	25.5	0.54	220-240 380-420 460	50 50 60	2.42 1.40 1.40	2800 2800 3300
<b>SBA142</b>	100/13	544	410	181	28.5	1.1	220-240 380-420 460	50 50 60	5.0 2.9 2.9	2700 2700 3300
<b>SBA143</b>	100/20	600	443	203	38.5	1.5	220-240 380-420 460	50 50 60	6.6 3.8 3.8	2850 2850 3400

### Horizontal End-Suction Pumps

are centrifugal inline pumps with a compact design where the impeller is mounted onto the extended motor shaft.

These pumps are not self-priming and must be gravity fed. All pumps are equipped with a single mechanical seal.

Upon request a second mechanical seal is available to allow for dry-running (-GD).

This pump series is designed for horizontal installations next to a tank and for pumping **air entrained coolant** fluids, such as **water-soluble coolants or cutting oils**, as they occur in **high speed turning, milling or grinding applications**.

The SBA pumps are equipped with the user-friendly **(SAE) flange** connection which allows for either vertical or horizontal pipe connection and the connection of a pressure gauge with G 1/4.

For more information see mechanical features within the technical information section.

### Applications

- Types of fluid
  - water
  - coolants
  - cooling/cutting oils
- Kinematic viscosity
  - ...45 mm<sup>2</sup>/s (45 cSt)
- Pumping temperature
  - 0...80° C

### Construction

Pump body	cast iron
Cover	cast iron
Impeller axial	cast steel
Impeller radial	cast steel
Shaft	steel
Mechanical seal	SiC
Noise level	
SBA141...SBA142	64 dBA
SBA143	68 dBA

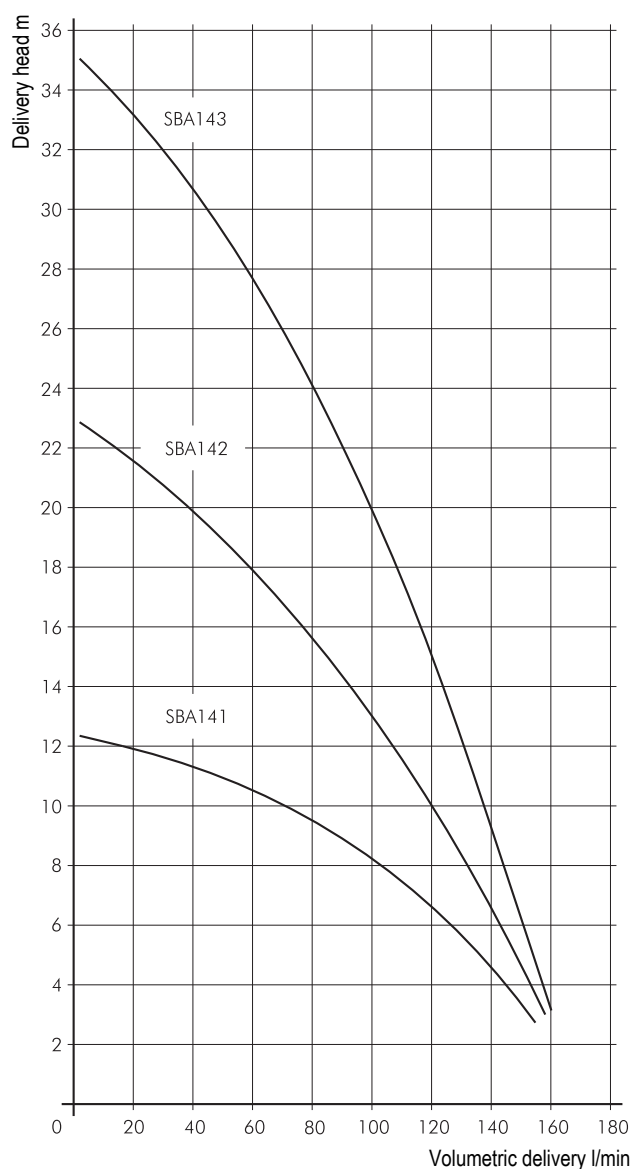

# Horizontal End-Suction Pumps

## SBA401...403

Axial/semi-open impellers

### SBA401...403

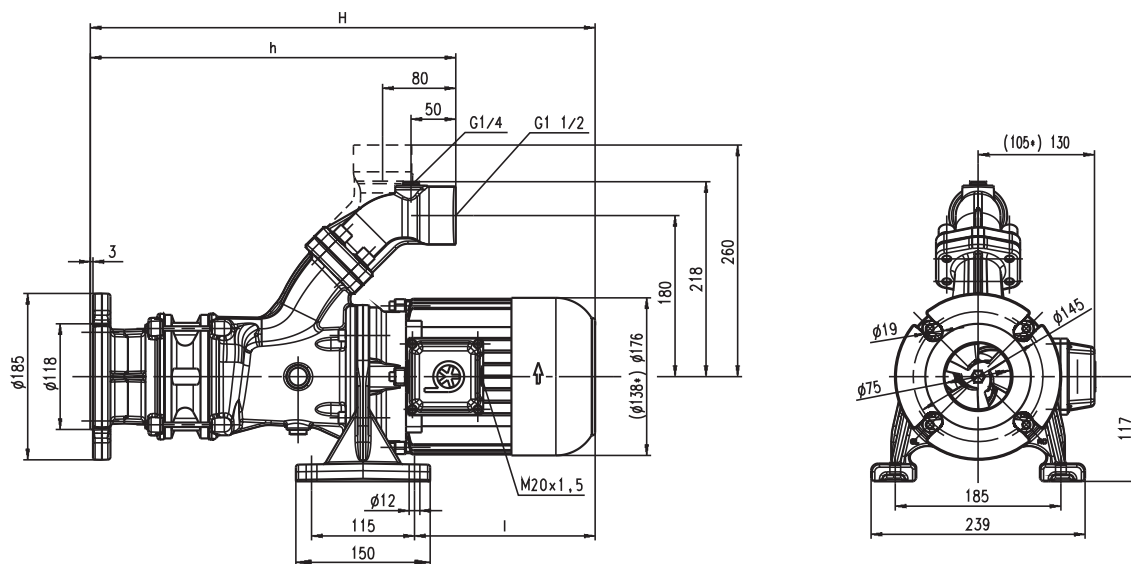

\*) Dimensions for SBA401

Type	Vol. del. at manom. del. head l/min /m	Dimensions H mm	h mm	Length l mm	Weight kg	Power kW	Voltage 3 ~ V	Fre- quency Hz	Rated current A	Speed 1/min
<b>SBA401</b>	200/6	474	359	161	25	0.85	220-240 380-420 460	50 50 60	4.3 2.5 2.5	2800 2800 3300
<b>SBA402</b>	200/14	565	408	203	39	1.3	220-240 380-420 460	50 50 60	5.2 3.0 3.0	2850 2850 3400
<b>SBA403</b>	200/20	614	457	203	41	1.7	220-240 380-420 460	50 50 60	7.1 4.1 4.1	2850 2850 3400





### Horizontal End-Suction Pumps

are centrifugal inline pumps with a compact design where the impeller is mounted onto the extended motor shaft.

These pumps are not self-priming and must be gravity fed. All pumps are equipped with a single mechanical seal.

Upon request a second mechanical seal is available to allow for dry-running (-GD).

This pump series is designed for horizontal installations next to a tank and for pumping **air entrained coolant** fluids, such as **water-soluble coolants or cutting oils**, as they occur in **high speed turning, milling or grinding applications**.

The SBA pumps are equipped with the user-friendly **(SAE) flange** connection which allows for either vertical or horizontal pipe connection and the connection of a pressure gauge with G 1/4.

For more information see mechanical features within the technical information section.

### Applications

Types of fluid  
 water  
 coolants  
 cooling/cutting oils  
 Kinematic viscosity  
 ...45 mm<sup>2</sup>/s (45 cSt)  
 Pumping temperature  
 0...80° C

### Construction

Pump body	cast iron
Cover	cast iron
Impeller axial	cast steel
Impeller radial	cast steel
Shaft	steel
Mechanical seal	SiC
Noise level	
SBA401	62 dBA
SBA402...SBA403	66 dBA

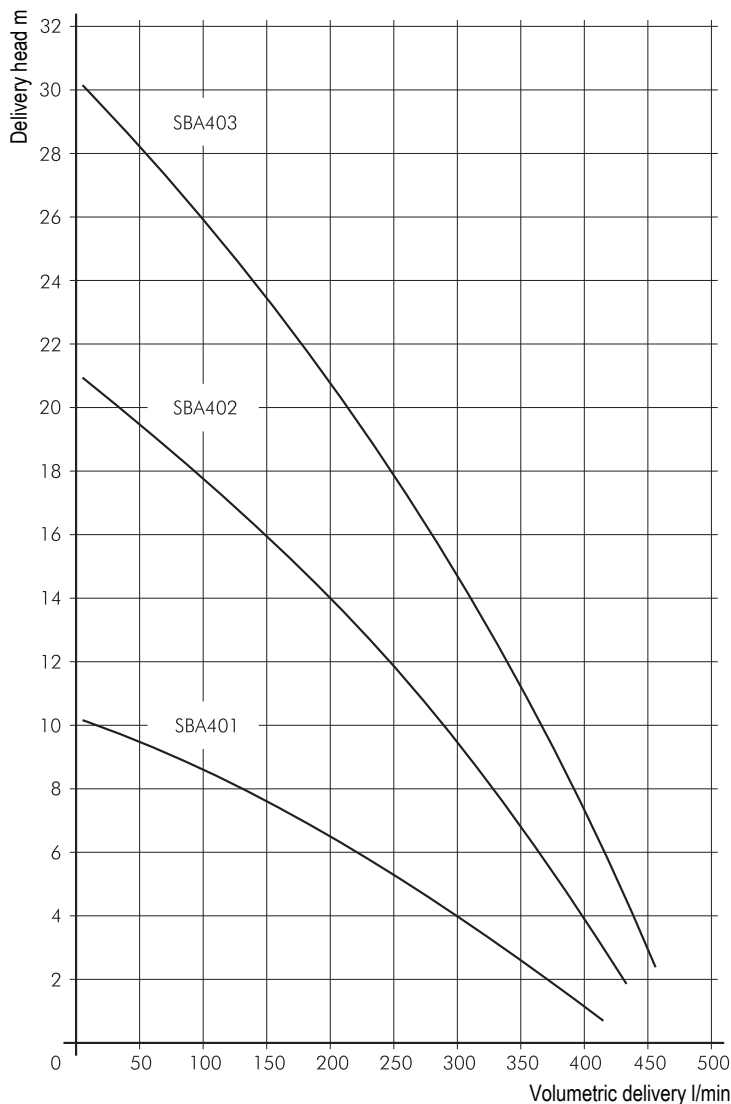

# Horizontal End-Suction Pumps

## SBA601...603

Axial/semi-open impellers

### SBA601...603

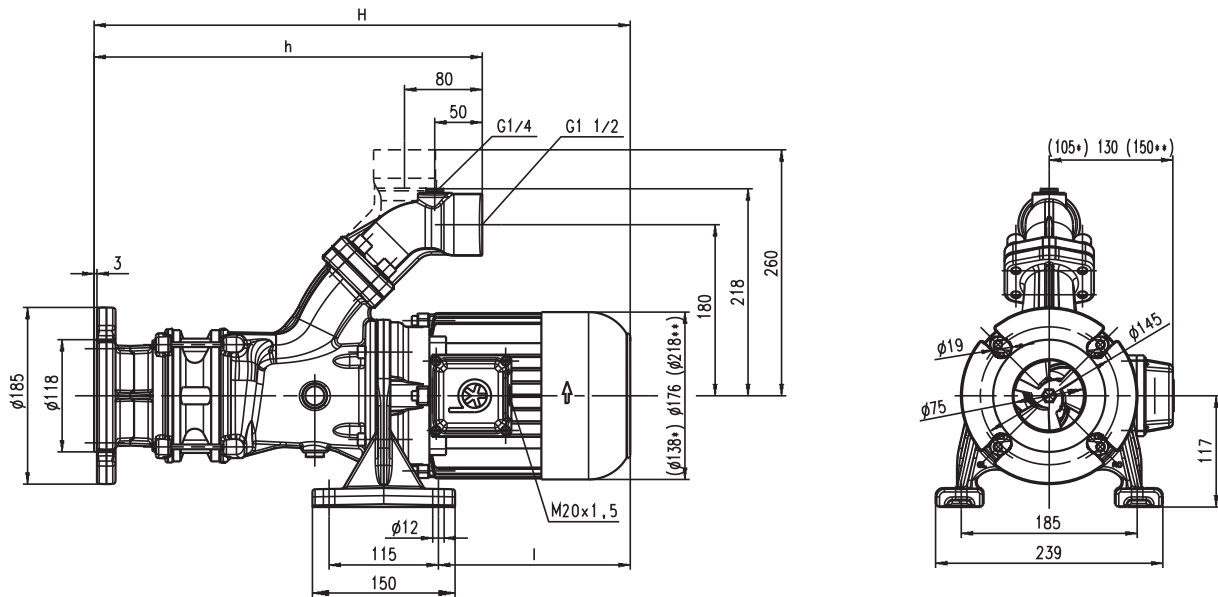

\*) Dimensions for SBA601  
 \*\*) Dimensions for SBA603



Type	Vol. del. at manom. del. head l/min /m	Dimensions		Length l mm	Weight kg	Power kW	Voltage 3 ~ V	Fre- quency Hz	Rated current A	Speed 1/min
		H mm	h mm							
<b>SBA601</b>	300/6	474	359	161	26	0.92	220-240	50	4.7	2700
							380-420	50	2.7	2700
							460	60	2.7	3300
<b>SBA602</b>	300/16	620	423	243	43	2.2	220-240	50	9.2	2850
							380-420	50	5.3	2850
							460	60	5.3	3400
<b>SBA603</b>	300/25	733	487	293	48	3.3	220-240	50	13.8	2900
							380-420	50	8.0	2900
							460	60	8.0	3450

### Horizontal End-Suction Pumps

are centrifugal inline pumps with a compact design where the impeller is mounted onto the extended motor shaft.

These pumps are not self-priming and must be gravity fed. All pumps are equipped with a single mechanical seal.

Upon request a second mechanical seal is available to allow for dry-running (-GD).

This pump series is designed for horizontal installations next to a tank and for pumping **air entrained coolant** fluids, such as **water-soluble coolants or cutting oils**, as they occur in **high speed turning, milling or grinding applications**.

The SBA pumps are equipped with the user-friendly **(SAE) flange** connection which allows for either vertical or horizontal pipe connection and the connection of a pressure gauge with G 1/4.

For more information see mechanical features within the technical information section.

### Applications

Types of fluid  
 water  
 coolants  
 cooling/cutting oils  
 Kinematic viscosity  
 ...45 mm<sup>2</sup>/s (45 cSt)  
 Pumping temperature  
 0...80° C

### Construction

Pump body	cast iron
Cover	cast iron
Impeller axial	cast steel
Impeller radial	cast steel
Shaft	steel
Mechanical seal	SiC
Noise level	
SBA601	62 dBA
SBA602	66 dBA
SBA603	68 dBA

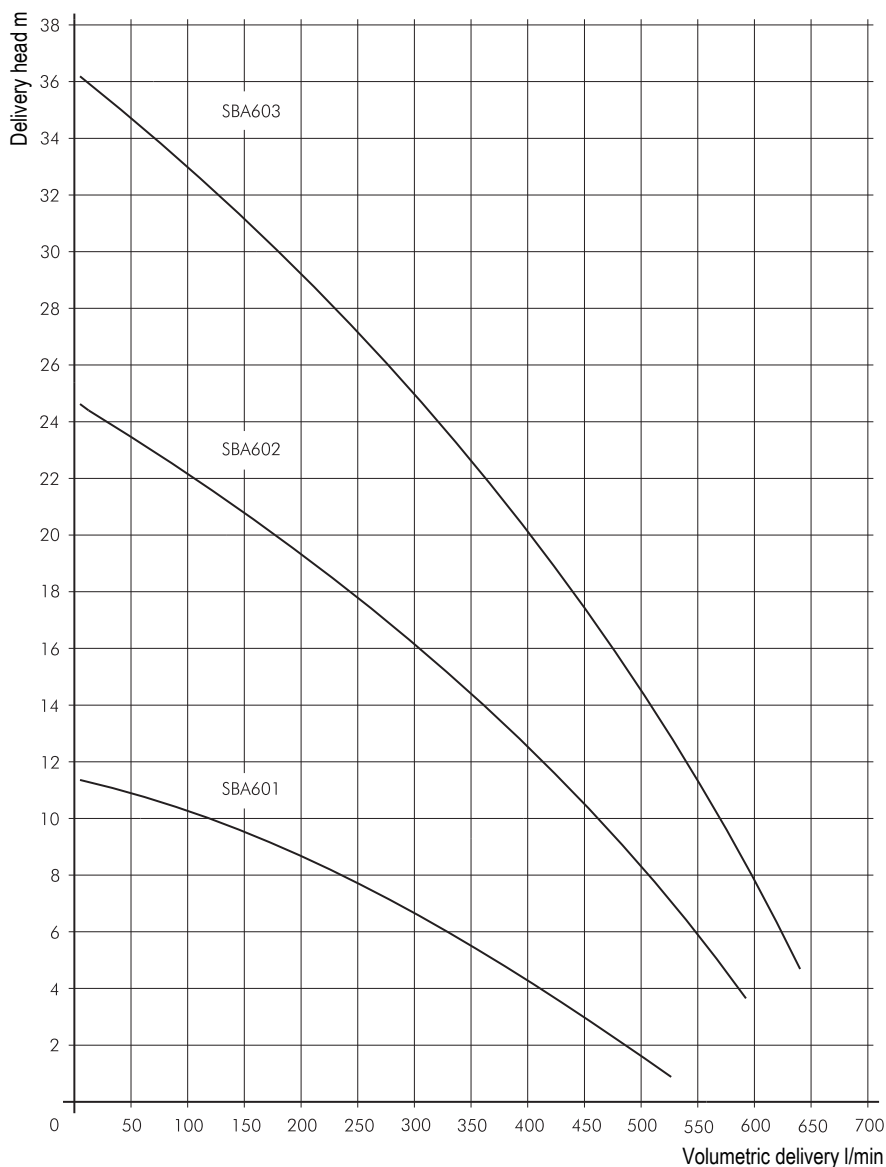

# Horizontal End-Suction Pumps

## BAL/SBA901...903

Axial/semi-open impellers

### BAL901...903

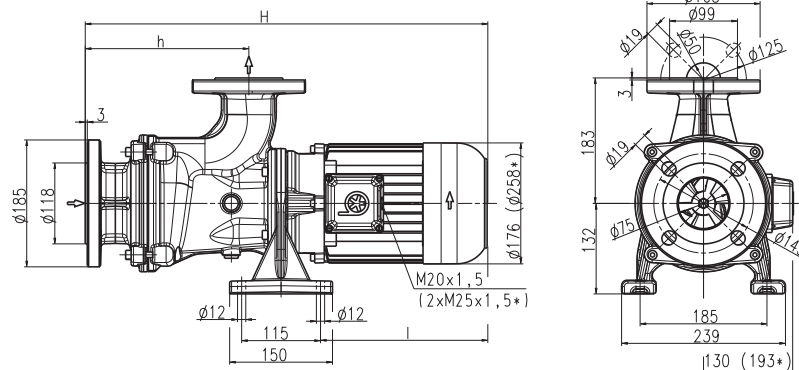

### SBA901...903

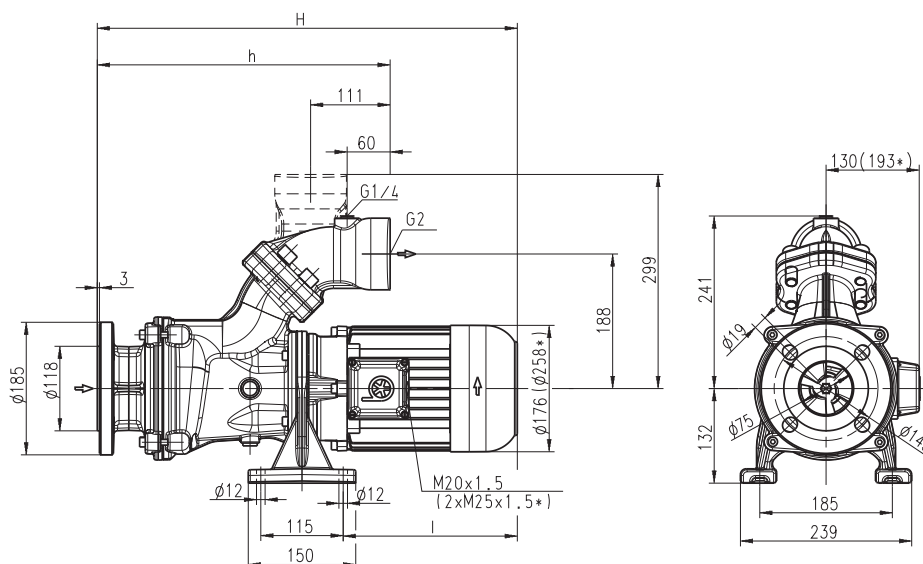

\*) Dimensions for BAL/SBA902, 903

Type	Vol. del. at manom. del. head l/min / m	Dimensions		Length l mm	Weight kg	Power kW	Voltage 3 ~ V	Fre- quency Hz	Rated current A	Speed 1/min
		H mm	h mm							
<b>BAL901</b>	600/11	596	239	253	50	2.6	220-240	50	10.9	2850
<b>SBA901</b>			408							
<b>BAL902</b>	600/22	742	309	329	83					
<b>SBA902</b>			478			86				
<b>BAL903</b>	600/36	850	379	367	103		7.5	220-240	50	29
<b>SBA903</b>			548			106				

### Horizontal End-Suction Pumps

are centrifugal inline pumps with a compact design where the impeller is mounted onto the extended motor shaft.

These pumps are not self-priming and must be gravity fed. All pumps are equipped with a single mechanical seal.

Upon request a second mechanical seal is available to allow for dry-running (-GD).

This pump series is designed for horizontal installations next to a tank and for pumping **air entrained coolant** fluids, such as **water-soluble coolants or cutting oils**, as they occur in **high speed turning, milling or grinding applications**.

The SBA pumps are equipped with the user-friendly 45 degree **flange** connection which allows for either vertical or horizontal pipe connection and the connection of a pressure gauge with G 1/4.

For more information see mechanical features within the technical information section.

### Applications

Types of fluid  
 water  
 coolants  
 cooling/cutting oils  
 Kinematic viscosity  
 ...45 mm<sup>2</sup>/s (45 cSt)  
 Pumping temperature  
 0...80° C

### Construction

Pump body	cast iron
Cover	cast iron
Impeller axial	cast steel
Impeller radial	cast steel
Shaft	steel
Mechanical seal	SiC
Noise level	
BAL901...SBA901	68 dBA
BAL902...SBA902	71 dBA
BAL903...SBA903	74 dBA

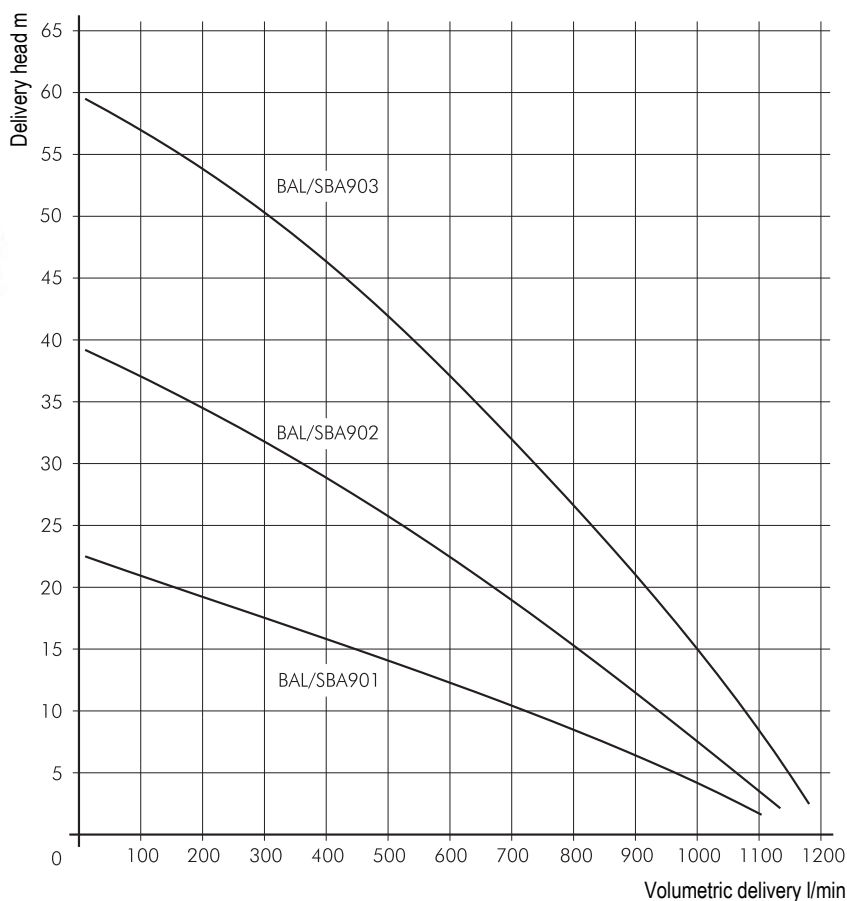

# Horizontal End-Suction Pumps



## BAL/SBA1301...1303

Axial/semi-open impellers

### BAL1301...1303

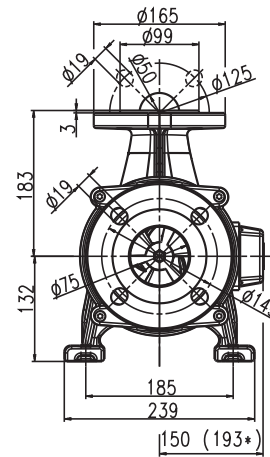
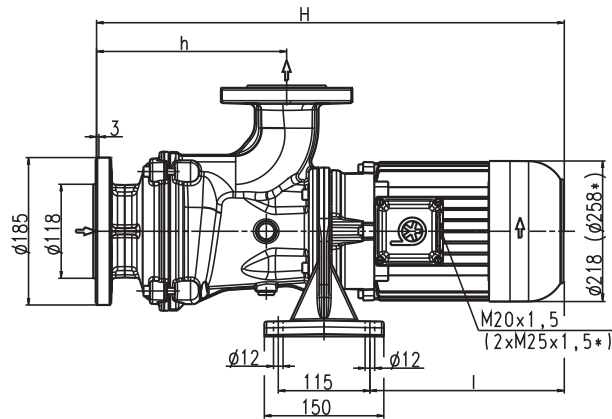

### SBA1301...1303

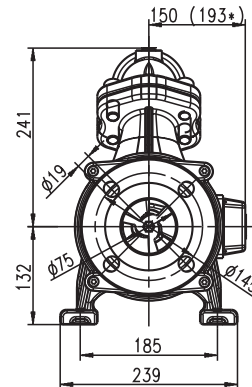
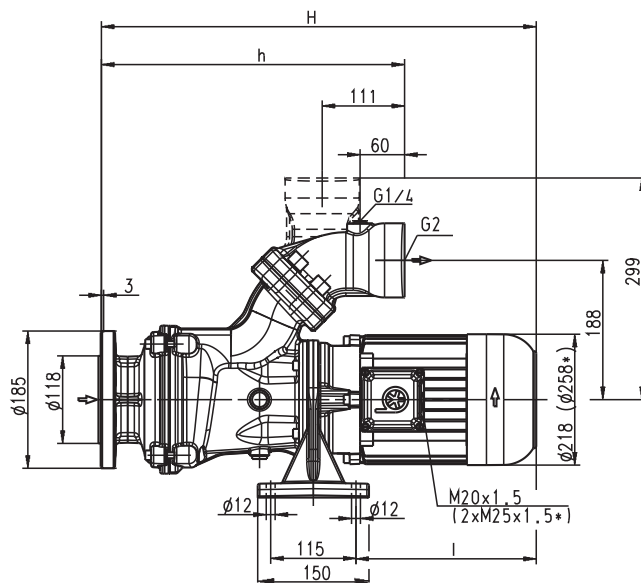

\*) Dimensions for BAL/SBA1302, 1303

Type	Vol. del. at manom. del. head l/min / m	Dimensions H mm	h mm	Length l mm	Weight kg	Power kW	Voltage 3~ V	Frequency Hz	Rated current A	Speed 1/min
<b>BAL1301</b>	900/12	640	243	293	58	4.0	220-240	50	16.5	2900
<b>SBA1301</b>			412		61		380-420	50	9.5	2900
							460	60	9.5	3450
<b>BAL1302</b>	900/24	794	323	367	96	7.5	220-240	50	29	2900
<b>SBA1302</b>			492		99		380-420	50	17	2900
							460	60	17	3450
<b>BAL1303</b>	900/35	923	403	416	116	10.0	220-240	50	40	2900
<b>SBA1303</b>			572		119		380-420	50	23	2900
							460	60	23	3450

### Horizontal End-Suction Pumps

are centrifugal inline pumps with a compact design where the impeller is mounted onto the extended motor shaft.

These pumps are not self-priming and must be gravity fed. All pumps are equipped with a single mechanical seal.

Upon request a second mechanical seal is available to allow for dry-running (-GD).

This pump series is designed for horizontal installations next to a tank and for pumping **air entrained coolant** fluids, such as **water-soluble coolants or cutting oils**, as they occur in **high speed turning, milling or grinding applications**.

The SBA pumps are equipped with the user-friendly 45 degree **flange** connection which allows for either vertical or horizontal pipe connection and the connection of a pressure gauge with G 1/4.

For more information see mechanical features within the technical information section.

### Applications

- Types of fluid
  - water
  - coolants
  - cooling/cutting oils
- Kinematic viscosity
  - ...45 mm<sup>2</sup>/s (45 cSt)
- Pumping temperature
  - 0...80° C

### Construction

Pump body	cast iron
Cover	cast iron
Impeller axial	cast steel
Impeller radial	cast steel
Shaft	steel
Mechanical seal	SiC
Noise level	
BAL1301...SBA1301	71 dBA
BAL1302...SBA1303	74 dBA

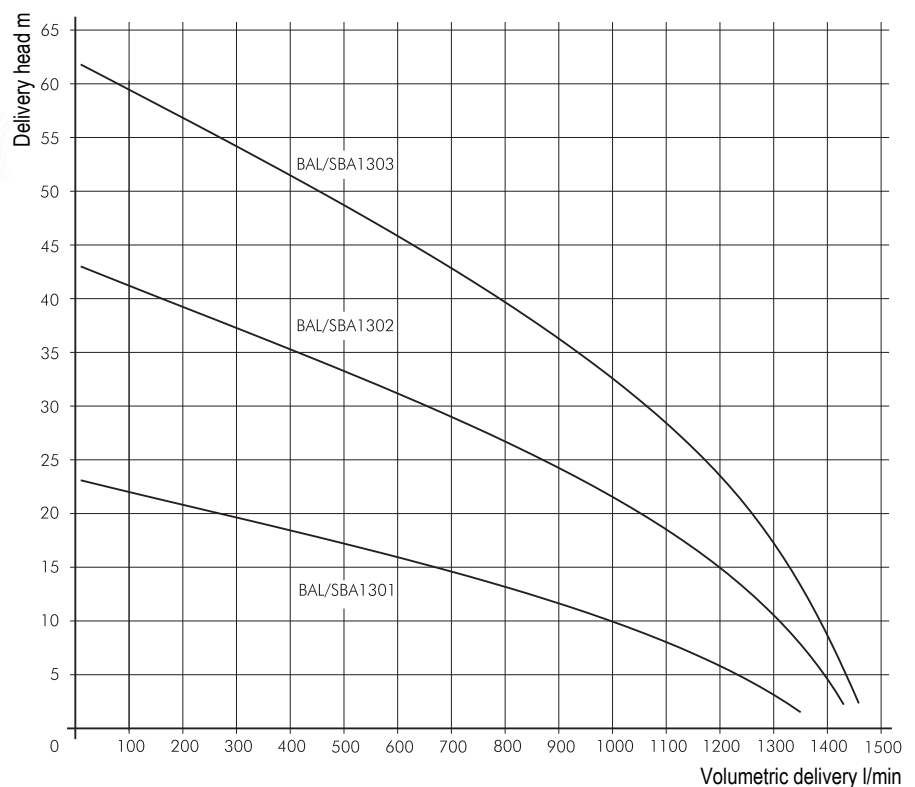

# Horizontal End-Suction Pumps

## SBA1600...2000

Axial/semi-open impellers

### SBA1600...2000

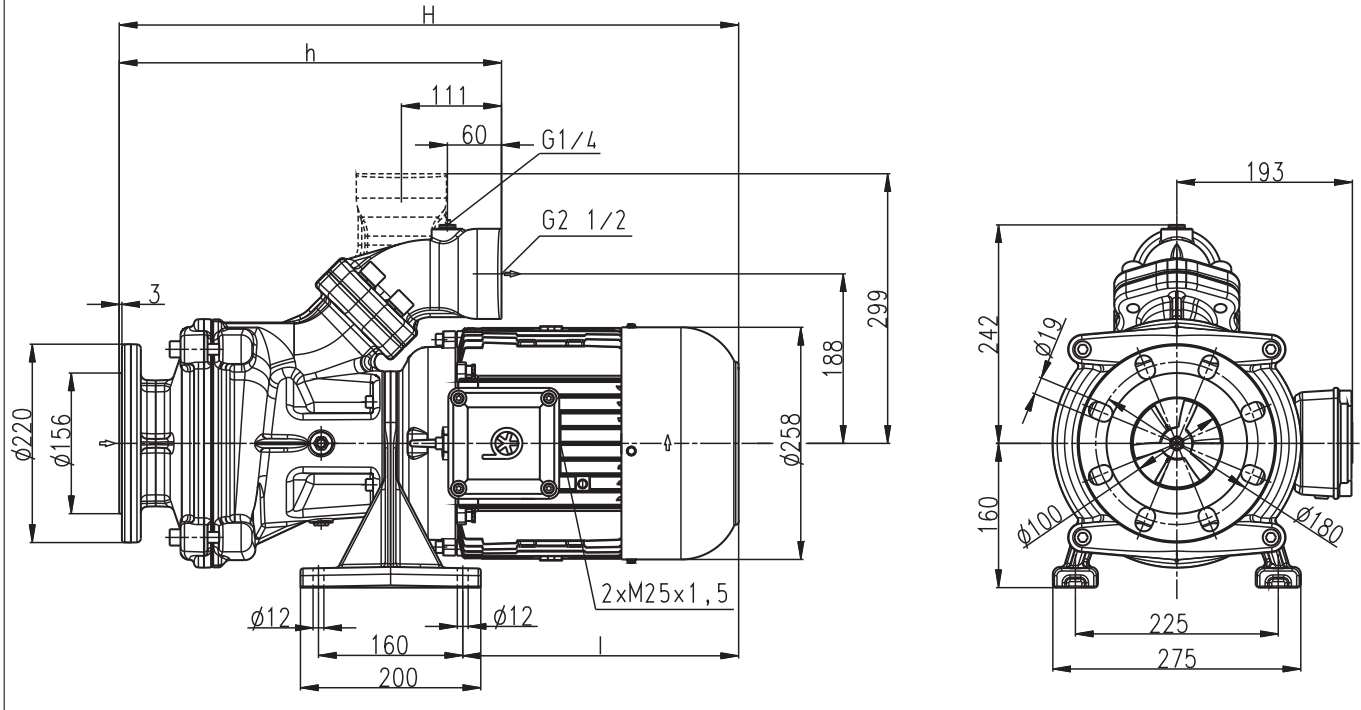

Type	Vol. del. at manom. del. head l/min / m	Dimensions H mm	h mm	Length l mm	Weight kg	Power kW	Voltage 3 ~ V	Fre- quency Hz	Rated current A	Speed 1/min
<b>SBA1600</b>	1400/15	724	424	343	100	7.5	220-240 380-420 460	50 50 60	29 17 17	2900 2900 3450
<b>SBA2000</b>	1600/19	774	424	393	119	10.0	220-240 380-420 460	50 50 60	40 23 23	2900 2900 3450



### Horizontal End-Suction Pumps

are centrifugal inline pumps with a compact design where the impeller is mounted onto the extended motor shaft.

These pumps are not self-priming and must be gravity fed. All pumps are equipped with a single mechanical seal.

Upon request a second mechanical seal is available to allow for dry-running (-GD).

This pump series is designed for horizontal installations next to a tank and for pumping **air entrained coolant** fluids, such as **water-soluble coolants or cutting oils**, as they occur in **high speed turning, milling or grinding applications**.

The SBA pumps are equipped with the user-friendly 45 degree **flange** connection which allows for either vertical or horizontal pipe connection and the connection of a pressure gauge with G 1/4.

For more information see mechanical features within the technical information section.

### Applications

Types of fluid  
 water  
 coolants  
 cooling/cutting oils  
 Kinematic viscosity  
 ...45 mm<sup>2</sup>/s (45 cSt)  
 Pumping temperature  
 0...80° C

### Construction

Pump body	cast iron
Cover	cast iron
Impeller axial	cast steel
Impeller radial	cast steel
Shaft	steel
Mechanical seal	SiC
Noise level	
SBA1600...SBA2000	74 dBA

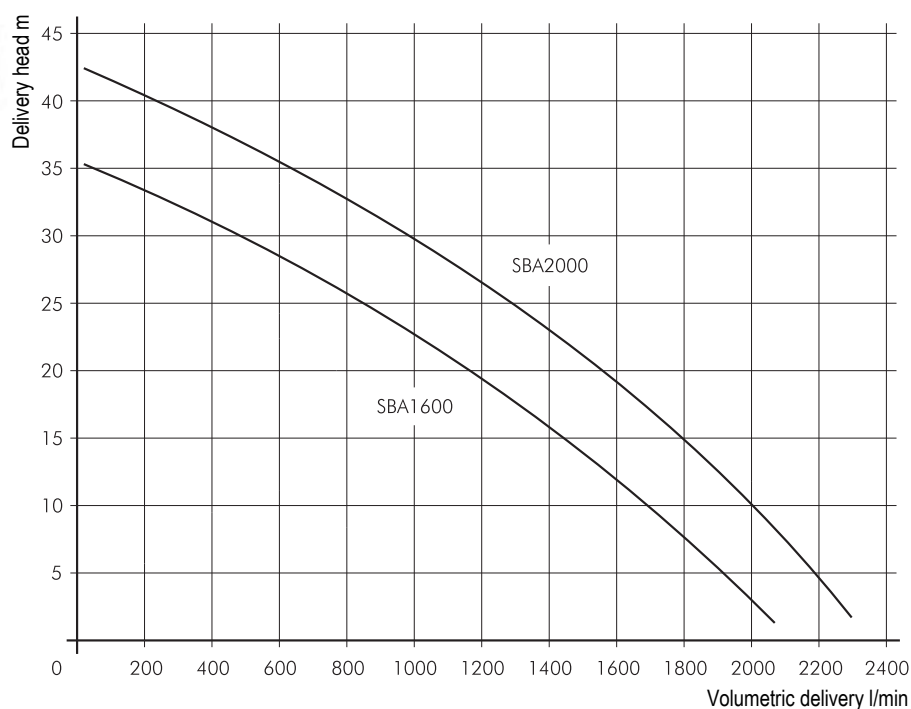

# Horizontal End-Suction Pumps

## SBG501...503

Axial/semi-open impellers

### SBG501...503

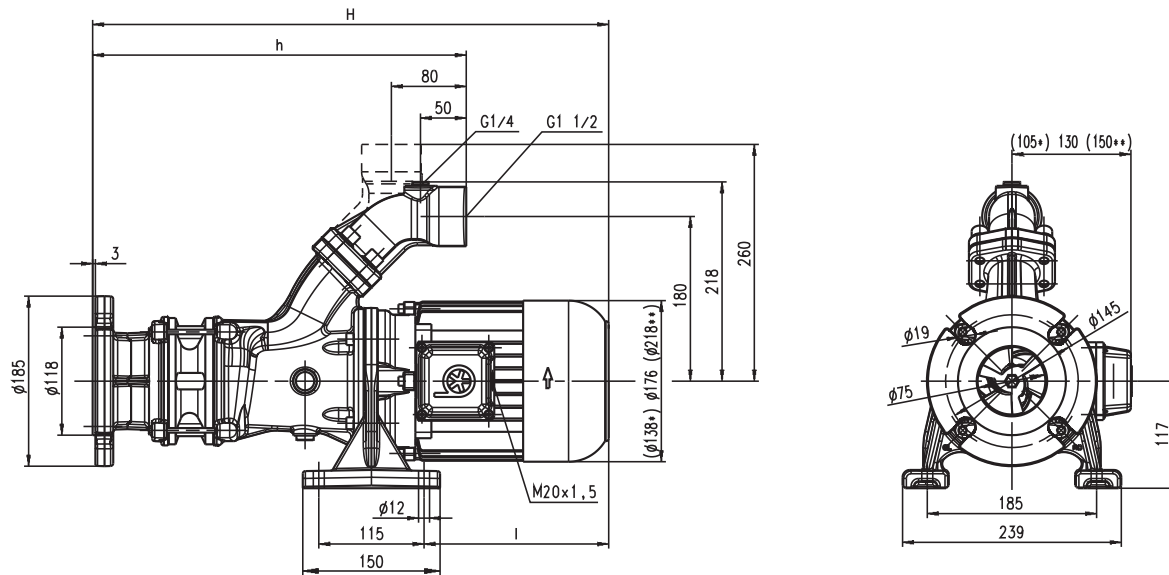

\*) Dimensions for SBG501

\*\*) Dimensions for SBG503

Type	Vol. del. at manom. del. head l/min /m	Dimensions		Length l mm	Weight kg	Power kW	Voltage 3 ~ V	Fre- quency Hz	Rated current A	Speed 1/min
		H mm	h mm							
<b>SBG501</b>	250/6	494	359	181	27	1.1	220-240 380-420 460	50 50 60	5.0 2.9 2.9	2700 2700 3300
<b>SBG502</b>	250/15	620	423	243	43	2.2	220-240 380-420 460	50 50 60	9.2 5.3 5.3	2850 2850 3400
<b>SBG503</b>	250/22	733	487	293	48	3.3	220-240 380-420 460	50 50 60	13.8 8.0 8.0	2900 2900 3450

### Horizontal End-Suction Pumps

are centrifugal inline pumps with a compact design where the impeller is mounted onto the extended motor shaft.

These pumps are not self-priming and must be gravity fed. All pumps are equipped with a single mechanical seal.

Upon request a second mechanical seal is available to allow for dry-running (-GD).

This pump series is designed for horizontal installations next to a tank and for pumping **highly air entrained coolant and cutting oils**, as they occur in **high speed grinding applications**.

The SBG pumps are equipped with the user-friendly **SAE flange** connection which allows for either vertical or horizontal pipe connection and the connection of a pressure gauge with G 1/4.

For more information see mechanical features within the technical information section.

### Applications

- Types of fluid
  - water
  - coolants
  - cooling/cutting oils
  - grinding oils
- Kinematic viscosity
  - ...45 mm<sup>2</sup>/s (45 cSt)
- Pumping temperature
  - 0...80° C

### Construction

Pump body	cast iron
Cover	cast iron
Impeller axial	cast steel
Impeller radial	cast steel
Shaft	steel
Mechanical seal	SiC
Noise level	
SBG501	67 dBA
SBG502	70 dBA
SBG503	72 dBA

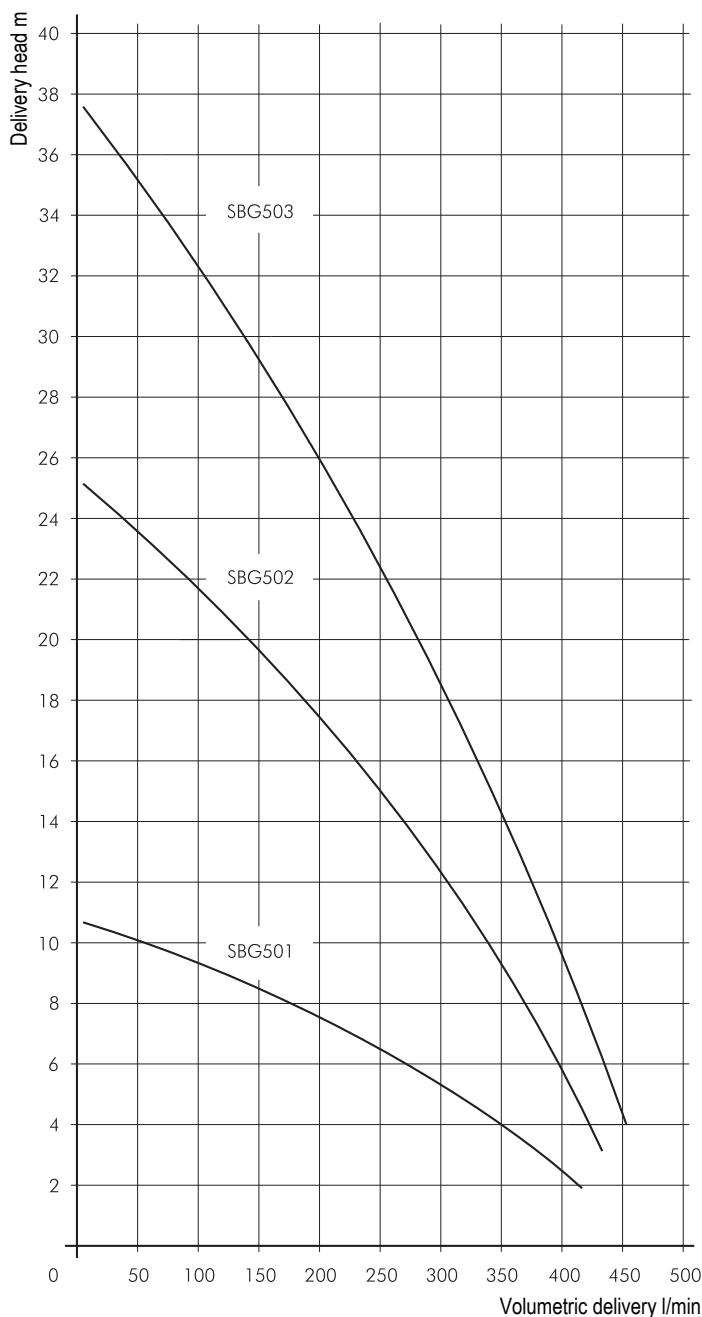

# Horizontal End-Suction Pumps

## BGL/SBG801...803

Axial/semi-open impellers

### BGL801...803

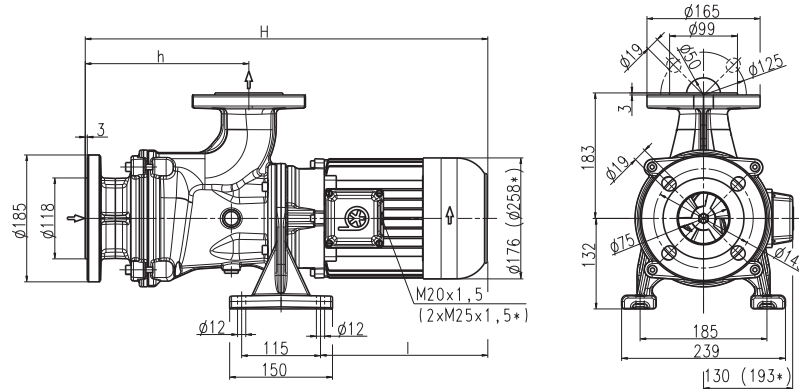

### SBG801...803

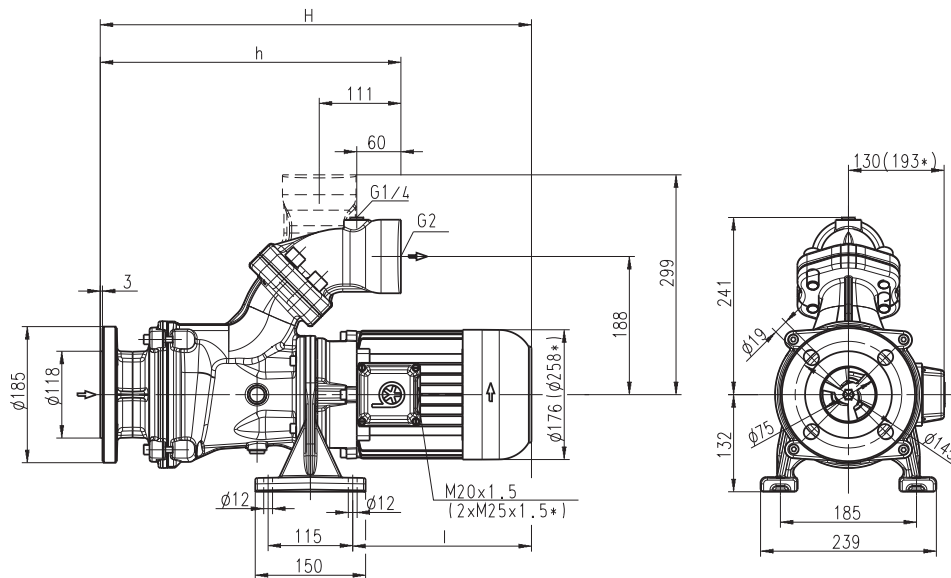

\*) Dimensions for BGL/SBG802, 803

Type	Vol. del. at manom. del. head l/min / m	Dimensions		Length l mm	Weight kg	Power kW	Voltage 3 ~ V	Fre- quency Hz	Rated current A	Speed 1/min	
		H mm	h mm								
<b>BGL801</b>	600/11	596	239	253	50	2.6	220-240	50	10.9	2850	
<b>SBG801</b>			408								53
<b>BGL802</b>	600/20	742	309	329	83						5.5
<b>SBG802</b>			478			86					
<b>BGL803</b>			850			379	367	103	7.5	220-240	
<b>SBG803</b>	548	106									
							380-420	50			17
							460	60	17	3450	

### Horizontal End-Suction Pumps

are centrifugal inline pumps with a compact design where the impeller is mounted onto the extended motor shaft.

These pumps are not self-priming and must be gravity fed. All pumps are equipped with a single mechanical seal.

Upon request a second mechanical seal is available to allow for dry-running (-GD).

This pump series is designed for horizontal installations next to a tank and for pumping **highly air entrained coolant and cutting oils**, as they occur in **high speed grinding applications**.

The SBG pumps are equipped with the user-friendly 45 degree **flange** connection which allows for either vertical or horizontal pipe connection and the connection of a pressure gauge with G 1/4.

For more information see mechanical features within the technical information section.

### Applications

- Types of fluid
  - water
  - coolants
  - cooling/cutting oils
  - grinding oils
- Kinematic viscosity
  - ...45 mm<sup>2</sup>/s (45 cSt)
- Pumping temperature
  - 0...80° C

### Construction

Pump body	cast iron
Cover	cast iron
Impeller axial	cast steel
Impeller radial	cast steel
Shaft	steel
Mechanical seal	SiC
Noise level	
BGL801...SBG801	70 dBA
BGL802...SBG802	73 dBA
BGL803...SBG803	75 dBA

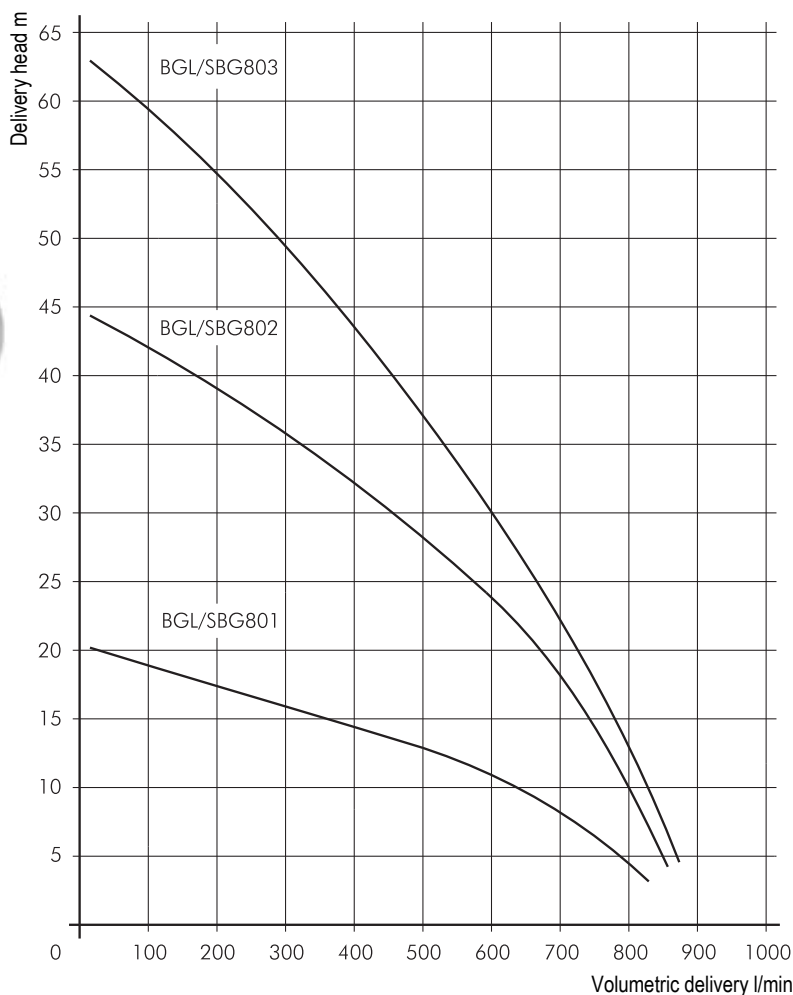

# Horizontal End-Suction Pumps

## BGL/SBG1101...1103

Axial/semi-open impellers

### BGL1101...1103

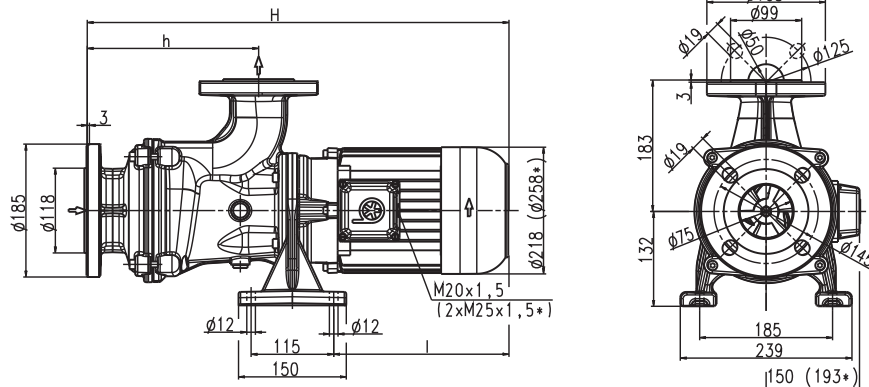

### SBG1101...1103

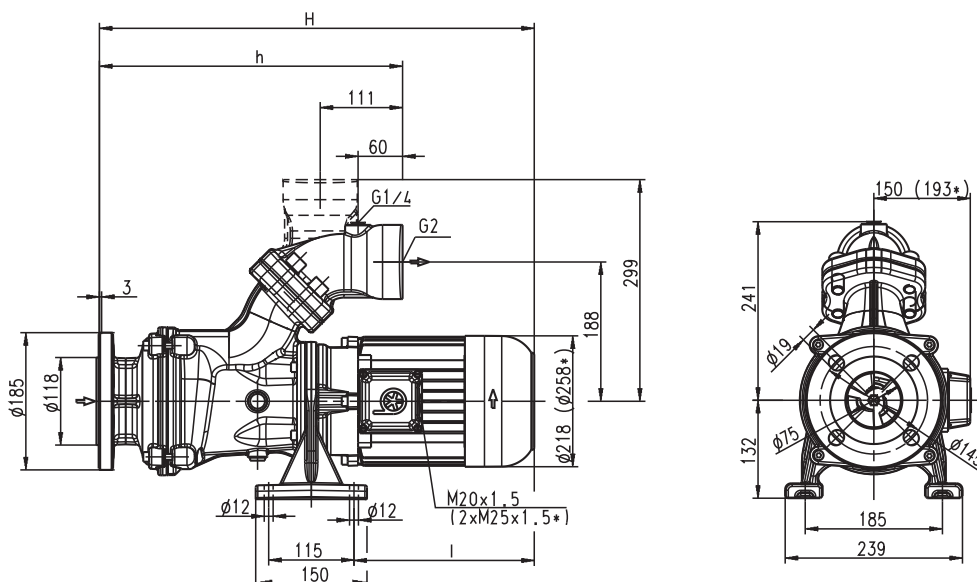

\*) Dimensions for BGL/SBG1102, 1103

Type	Vol. del. at manom. del. head l/min / m	Dimensions H mm	h mm	Length l mm	Weight kg	Power kW	Voltage 3 ~ V	Fre- quency Hz	Rated current A	Speed 1/min
<b>BGL1101</b>	900/12	640	243	293	58	4.0	220-240	50	16.5	2900
<b>SBG1101</b>			412		60		380-420	50	9.5	2900
							460	60	9.5	3450
<b>BGL1102</b>	900/21	794	323	367	106	7.5	220-240	50	29	2900
<b>SBG1102</b>			492		109		380-420	50	17	2900
							460	60	17	3450
<b>BGL1103</b>	900/29	923	403	416	114	10.0	220-240	50	40	2900
<b>SBG1103</b>			572		117		380-420	50	23	2900
							460	60	23	3450

### Horizontal End-Suction Pumps

are centrifugal inline pumps with a compact design where the impeller is mounted onto the extended motor shaft.

These pumps are not self-priming and must be gravity fed. All pumps are equipped with a single mechanical seal.

Upon request a second mechanical seal is available to allow for dry-running (-GD).

This pump series is designed for horizontal installations next to a tank and for pumping **highly air entrained coolant and cutting oils**, as they occur in **high speed grinding applications**.

The SBG pumps are equipped with the user-friendly 45 degree **flange** connection which allows for either vertical or horizontal pipe connection and the connection of a pressure gauge with G 1/4.

For more information see mechanical features within the technical information section.

### Applications

Types of fluid  
 water  
 coolants  
 cooling/cutting oils  
 grinding oils  
 Kinematic viscosity  
 ...45 mm<sup>2</sup>/s (45 cSt)  
 Pumping temperature  
 0...80° C

### Construction

Pump body	cast iron
Cover	cast iron
Impeller axial	cast steel
Impeller radial	cast steel
Shaft	steel
Mechanical seal	SiC
Noise level	
BGL1101...SBG1101	72 dBA
BGL1102...SBG1103	75 dBA

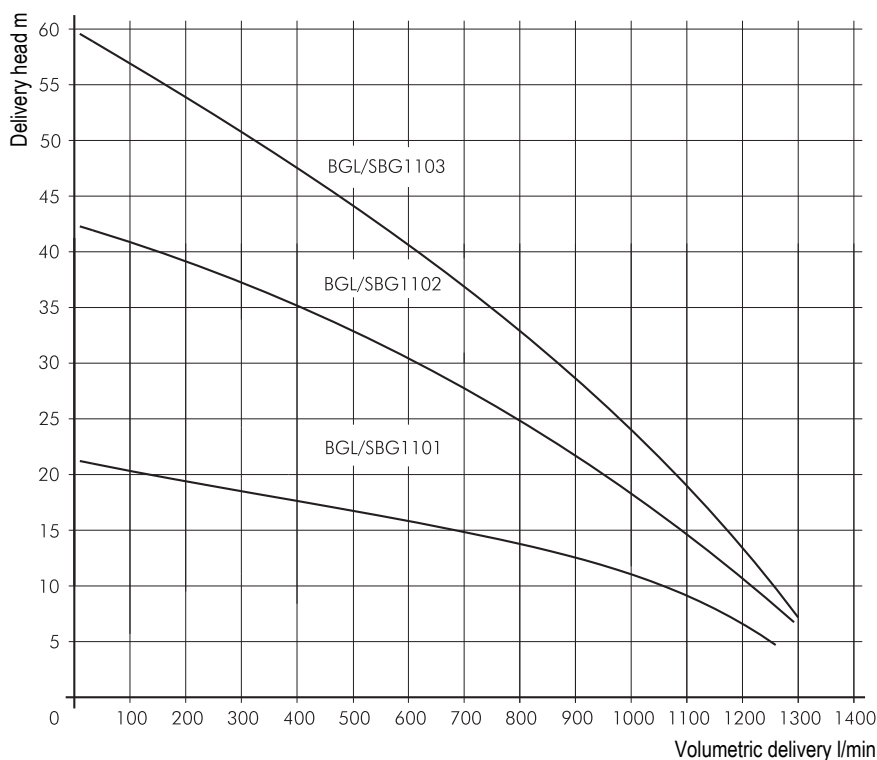

# Horizontal End-Suction Pumps

## SBG1700

Axial/semi-open impellers

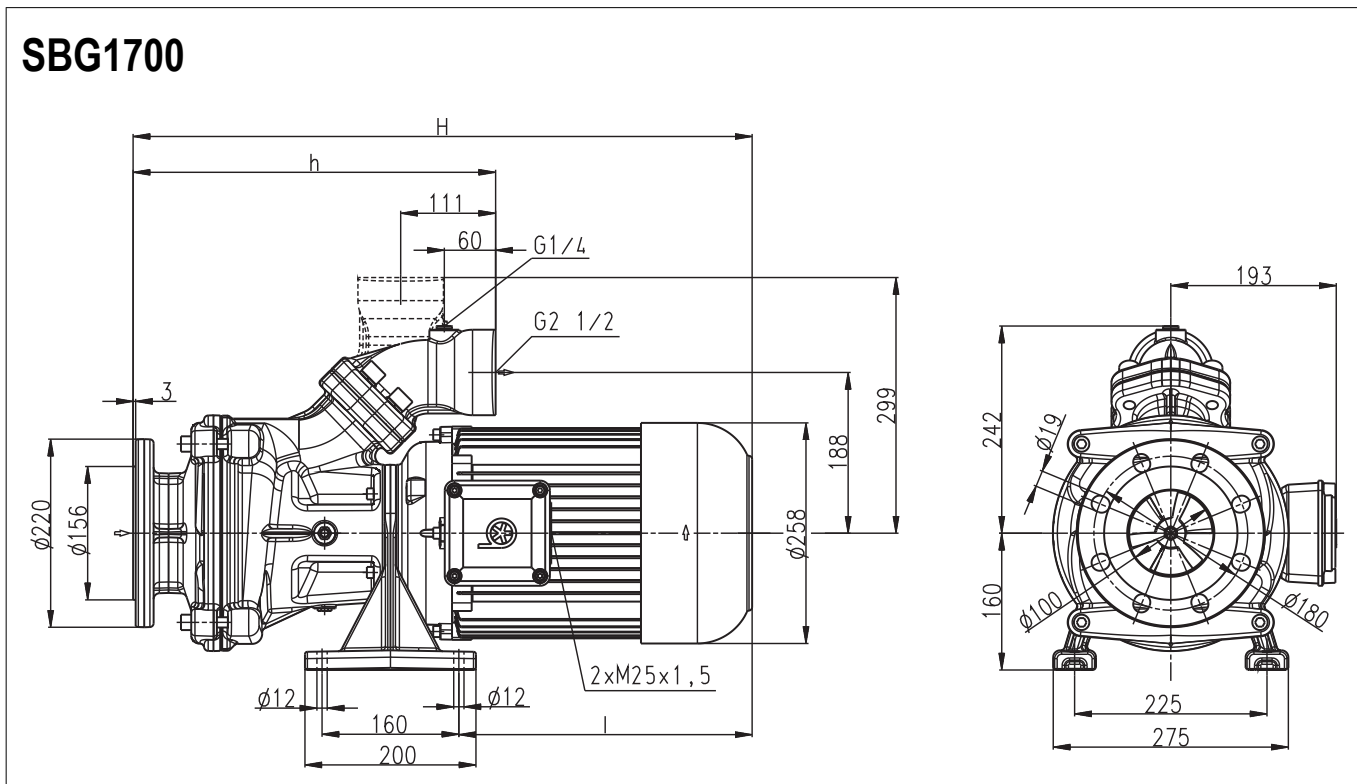

Type	Vol. del. at manom. del. head l/min /m	Dimensions		Length l mm	Weight kg	Power kW	Voltage 3 ~ V	Fre- quency Hz	Rated current A	Speed 1/min
		H mm	h mm							
<b>SBG1700</b>	1500/20	774	424	393	119	10.0	220-240 380-420 460	50 50 60	40 23 23	2900 2900 3450



### Horizontal End-Suction Pumps

are centrifugal inline pumps with a compact design where the impeller is mounted onto the extended motor shaft.

These pumps are not self-priming and must be gravity fed. All pumps are equipped with a single mechanical seal.

Upon request a second mechanical seal is available to allow for dry-running (-GD).

This pump series is designed for horizontal installations next to a tank and for pumping **highly air entrained coolant and cutting oils**, as they occur in **high speed grinding applications**.

The SBG pumps are equipped with the user-friendly 45 degree **flange** connection which allows for either vertical or horizontal pipe connection and the connection of a pressure gauge with G 1/4.

For more information see mechanical features within the technical information section.

### Applications

Types of fluid  
 water  
 coolants  
 cooling/cutting oils  
 grinding oils  
 Kinematic viscosity  
 ...45 mm<sup>2</sup>/s (45 cSt)  
 Pumping temperature  
 0...80° C

### Construction

Pump body	cast iron
Cover	cast iron
Impeller axial	cast steel
Impeller radial	cast steel
Shaft	steel
Mechanical seal	SiC
Noise level SBG1700	74 dBA

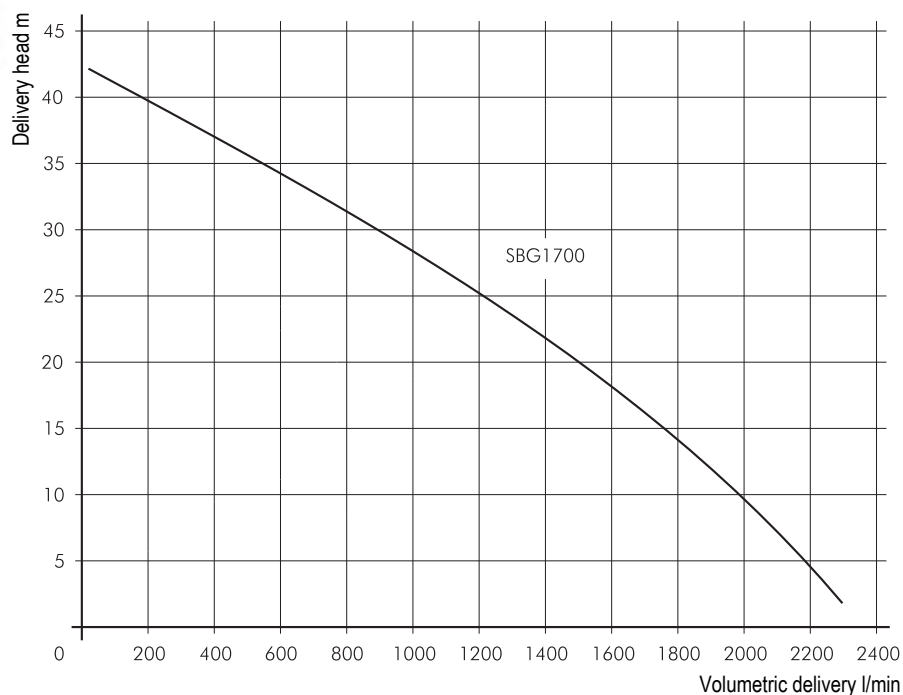

# Horizontal End-Suction Pumps

## BFL/SBF550...1150

Axial/semi-open impellers

### BFL650...1150

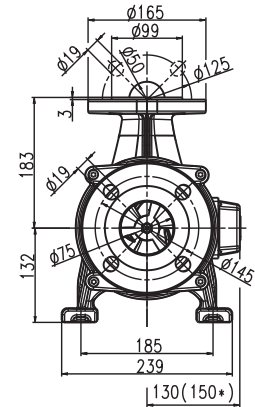
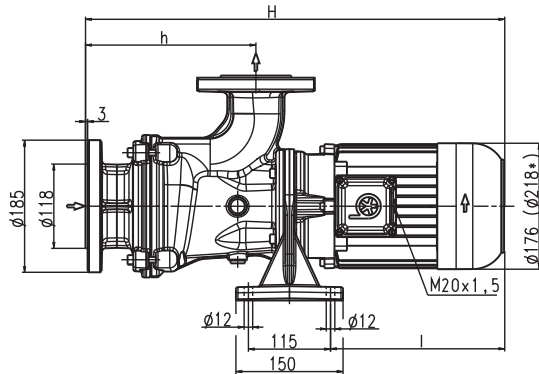

### SBF550...1150

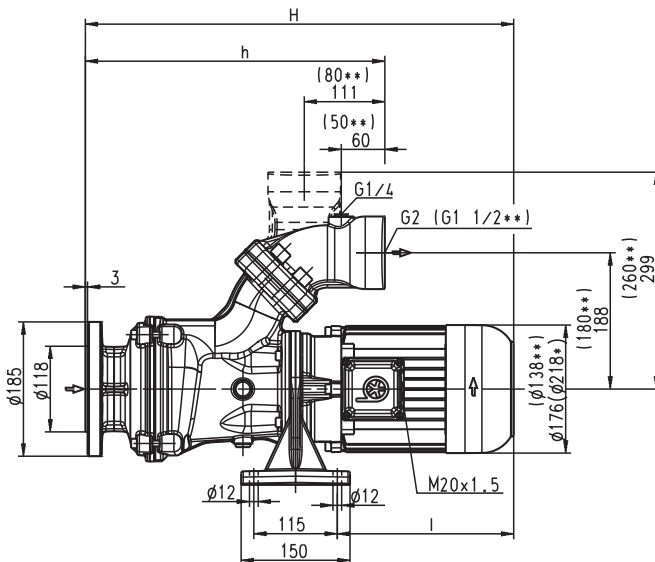

SBF550

SBF650, 850, 1150

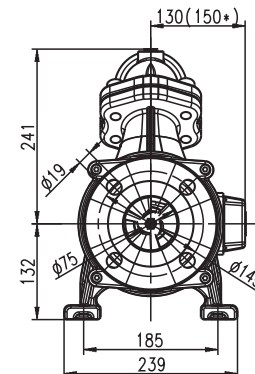
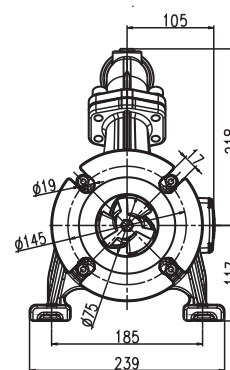

\*) Dimensions for BFL/SBF1150

\*\*) Dimensions for SBF550



Type	Vol. del. at manom. del. head l/min /m	Dimensions H mm	h mm	Length l mm	Weight kg	Power kW	Voltage 3 ~ V	Frequency Hz	Rated current A	Speed 1/min
<b>SBF550</b>	250/4	494	359	181	26.5	1.1	220-240 380-420 460	50 50 60	5.0 2.9 2.9	2700 2700 3300
<b>BFL650</b>	400/7	586	239	243	49	2.2	220-240 380-420 460	50 50 60	9.2 5.3 5.3	2850 2850 3400
<b>SBF650</b>		408			52					
<b>BFL850</b>	500/10	600	243	253	51					
<b>SBF850</b>		412			54					
<b>BFL1150</b>	600/13	640	243	293	58	4.0	220-240 380-420 460	50 50 60	16.5 9.5 9.5	2900 2900 3450
<b>SBF1150</b>		412			61					

### Horizontal End-Suction Pumps

are centrifugal inline pumps with a compact design where the impeller is mounted onto the extended motor shaft.

These pumps are not self-priming and must be gravity fed. All pumps are equipped with a single mechanical seal.

Upon request a second mechanical seal is available to allow for dry-running (-GD).

This pump series is designed for horizontal installations next to a tank and for pumping **air entrained coolant fluids**, such as **water-soluble coolants (emulsions)**, as they occur in **high speed machining applications, such as turning and milling**.

The SBF\* pumps are equipped with the user-friendly 45 degree **flange** connection which allows for either vertical or horizontal pipe connection and the connection of a pressure gauge with G 1/4.

\*) SBF550 with SAE flange.

For more information see mechanical features within the technical information section.

### Applications

Types of fluid

- water
- coolants
- cooling/cutting oils

Max. chip to coolant ratio by weight:  
1.0 % depending on the specific chip type

Chip material:

- Aluminium, steel, coloured steels,
- cast iron

Kinematic viscosity  
...45 mm<sup>2</sup>/s (45 cSt)

Pumping temperature  
0...80° C

### Construction

Pump body	cast iron
Cover	cast iron
Impeller axial	cast steel
Impeller radial	cast steel
Shaft	steel
Mechanical seal	SiC
Noise level	
SBF550	62 dBA
BFL650...SBF850	66 dBA
BFL1150...SBF1150	71 dBA

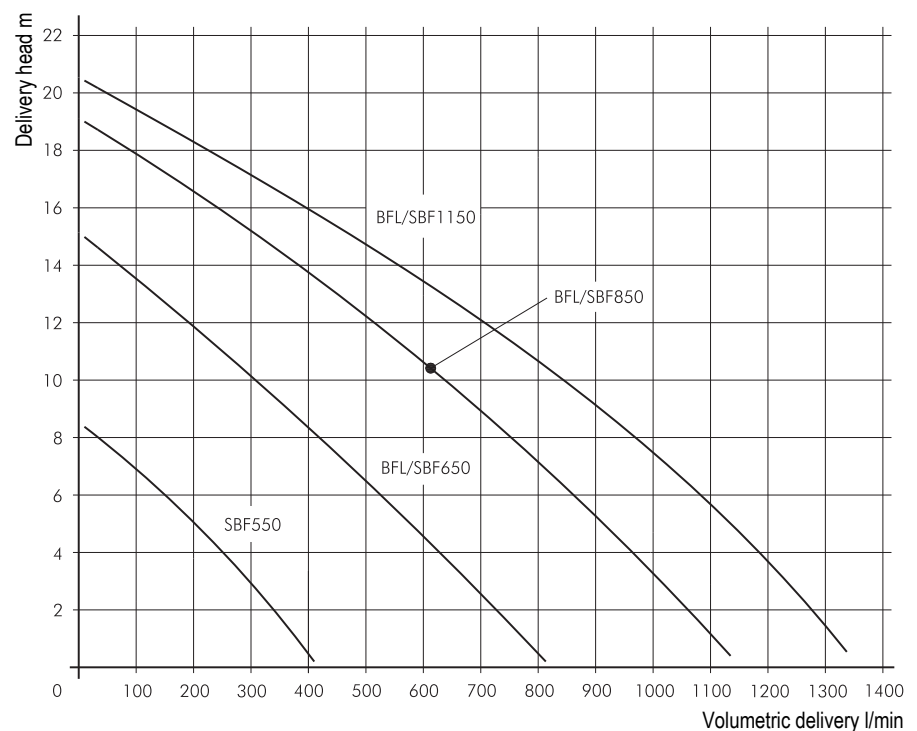

# Horizontal End-Suction Pumps

## SBF1350...1850

Axial/semi-open impellers

### SBF1350...1850

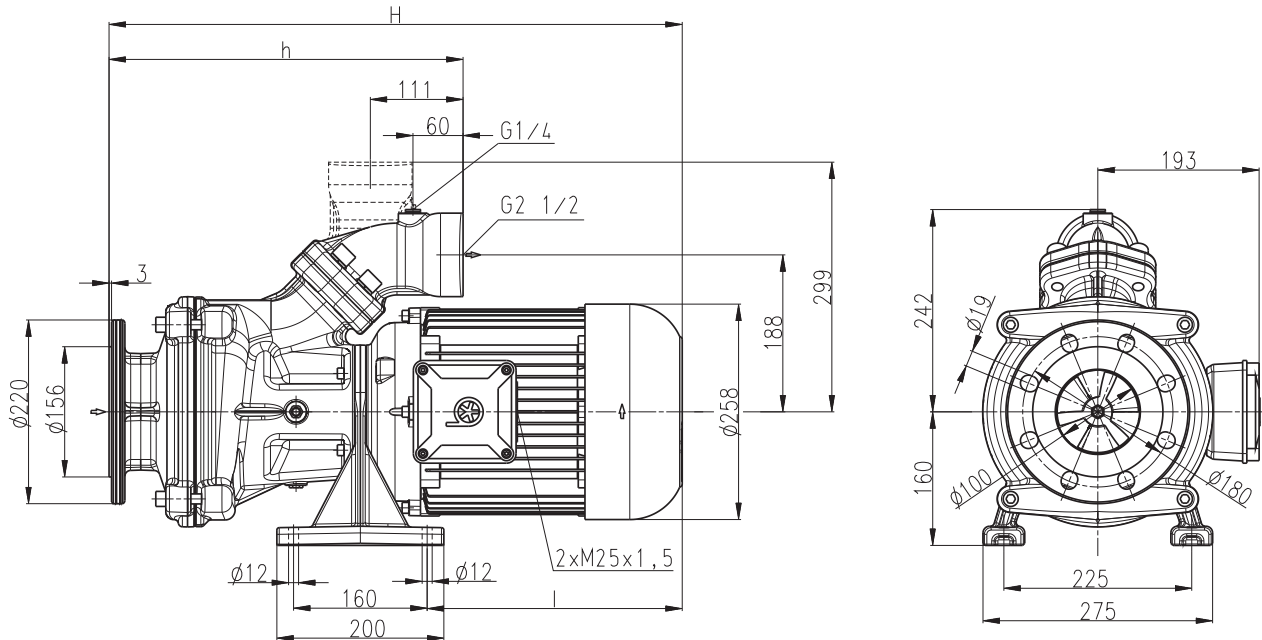

Type	Vol. del. at manom. del. head l/min /m	Dimensions		Length l mm	Weight kg	Power kW	Voltage 3 ~ V	Fre- quency Hz	Rated current A	Speed 1/min
		H mm	h mm							
<b>SBF1350</b>	600/15	686	424	305	92	5.5	220-240	50	22.0	2900
							380-420	50	12.5	2900
							460	60	12.5	3450
<b>SBF1550</b>	850/20	724	424	343	100	7.5	220-240	50	29	2900
							380-420	50	17	2900
							460	60	17	3450
<b>SBF1850</b>	1100/20	774	424	393	119	10.0	220-240	50	40	2900
							380-420	50	23	2900
							460	60	23	3450



### Horizontal End-Suction Pumps

are centrifugal inline pumps with a compact design where the impeller is mounted onto the extended motor shaft.

These pumps are not self-priming and must be gravity fed. All pumps are equipped with a single mechanical seal.

Upon request a second mechanical seal is available to allow for dry-running (-GD).

This pump series is designed for horizontal installations next to a tank and for pumping **highly air entrained coolant fluids**, such as **water-soluble coolants (emulsions)**, as they occur in **high speed machining applications, such as turning and milling**.

The SBF pumps are equipped with the user-friendly 45 degree **flange** connection which allows for either vertical or horizontal pipe connection and the connection of a pressure gauge with G 1/4.

For more information see mechanical features within the technical information section.

### Applications

Types of fluid

- water
- coolants
- cooling/cutting oils

Max. chip to coolant ratio by weight:  
1.0 % depending on the specific chip type

Chip material:

- Aluminium, steel, coloured steels,
- cast iron

Kinematic viscosity

...45 mm<sup>2</sup>/s (45 cSt)

Pumping temperature

0...80° C

### Construction

Pump body	cast iron
Cover	cast iron
Impeller axial	cast steel
Impeller radial	cast steel
Shaft	steel
Mechanical seal	SiC

Noise level

SBF1350	71 dBA
SBF1550...SBF1850	74 dBA

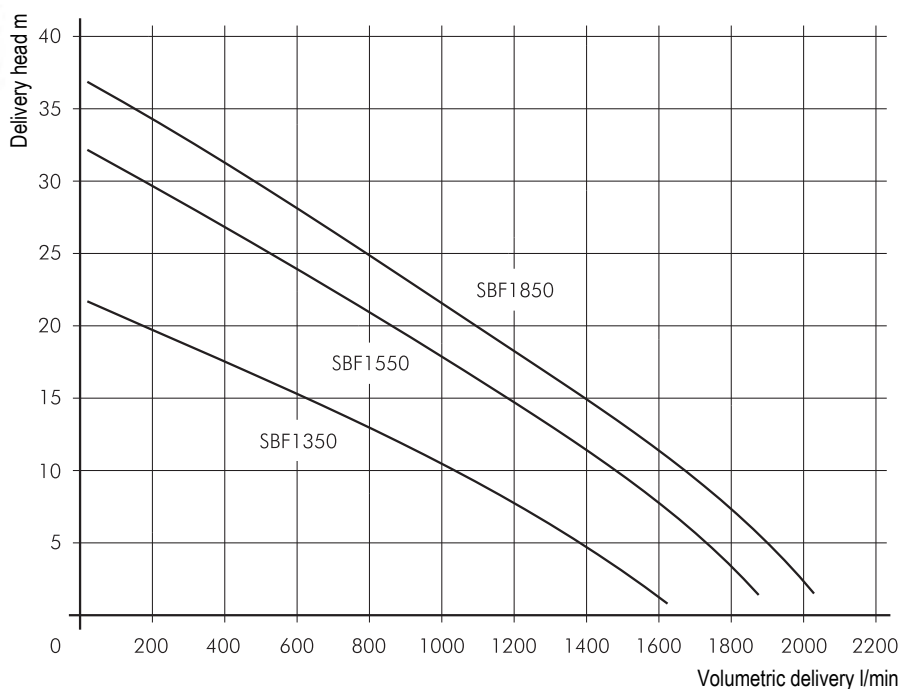

# Horizontal End-Suction Pumps

## SBC820...1120

Axial/semi-open impellers

### SBC820...1120

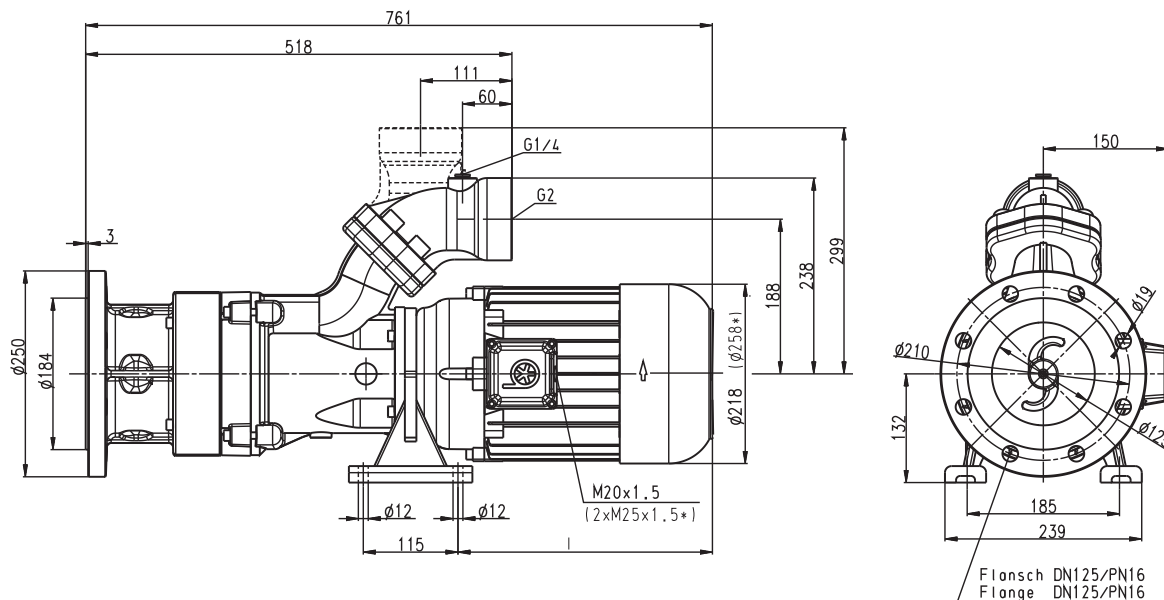

\*) Dimensions for SBC1120

Type	Vol. del. at manom. del. head l/min /m	Dimensions H mm	h mm	Length l mm	Weight kg	Power kW	Voltage 3 ~ V	Fre- quency Hz	Rated current A	Speed 1/min
<b>SBC820</b>	400/10	761	518	309	71	4.0	220-240 380-420 460	50 50 60	16.5 9.5 9.5	2900 2900 3450
<b>SBC1120</b>	600/10	797	518	345	93	5.5	220-240 380-420 460	50 50 60	22.0 12.5 12.5	2900 2900 3450



### Horizontal End-Suction Pumps

are centrifugal inline pumps with a compact design where the impeller is mounted onto the extended motor shaft.

These pumps are not self-priming and must be gravity fed. All pumps are equipped with double mechanical seal.

This pump series is designed for horizontal installations next to a tank and are capable of cutting aluminium chips and similar materials and pumping of these materials along with the coolant fluid. An agitator located at the pump suction helps to break up and separate any large bundles of chips or birds nests which reach the pump suction.

The specially made cutting unit (> 60 HRC) is cutting chips and the above located semi-open impeller allows with its large clearances to pump the particles along with the coolant fluid from the machine back to the filter. The SBC pumps are capable of handling chip to coolant ratios of up to 1.5% by weight.

The SBC pumps are equipped with the user-friendly 45 degree **flange** connection which allows for either vertical or horizontal pipe connection and the connection of a pressure gauge with G 1/4.

For more information see mechanical features within the technical information section (SFC).

### Applications

Types of fluid  
 water  
 coolants  
 cooling/cutting oils  
 Max. chip to coolant ratio by weight:  
 1.5 %  
 Chip material:  
 Aluminium  
 Chip geometry:  
 Chip bundles to max. Ø 100 mm  
 Kinematic viscosity  
 ...45 mm<sup>2</sup>/s (45 cSt)  
 Pumping temperature  
 0...80° C

### Construction

Pump body	cast iron
Cover	cast iron
Impeller axial	cast steel
Impeller radial	cast steel
Cutting unit	Hardened (>60 HRC)
Agitator	Highly ductile steel
Shaft	steel
Mechanical seal	SiC
Noise level	
SBC820...SBC1120	71 dBA

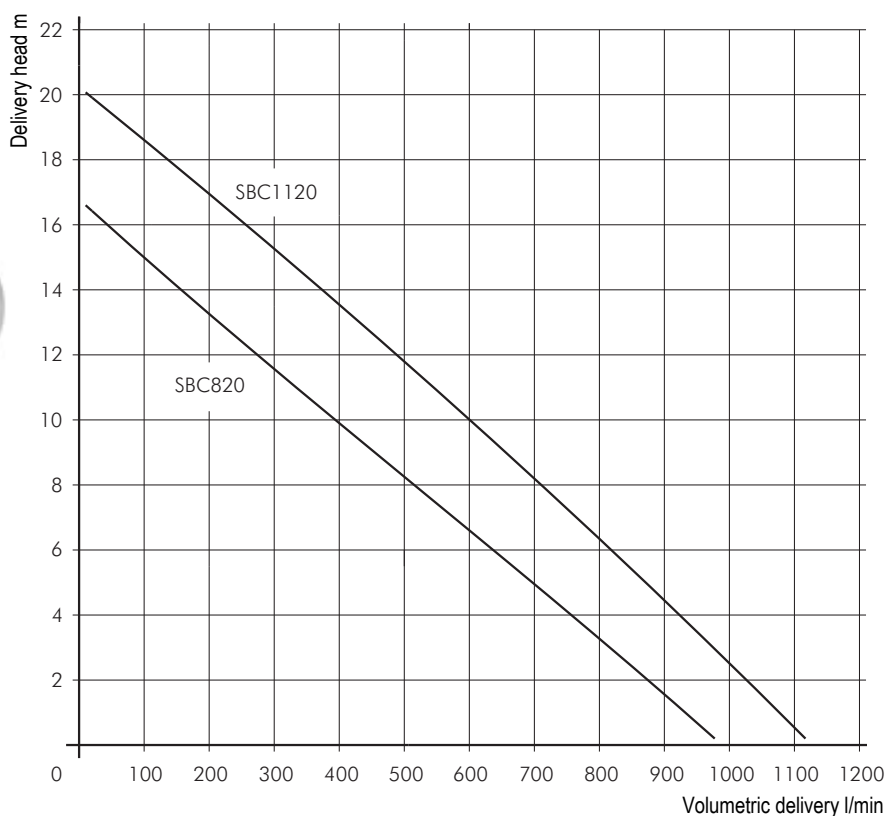

# Immersion Pumps

## TS12...TM26

### Peripheral impellers

#### TS12, 13, 21, 22 TS24

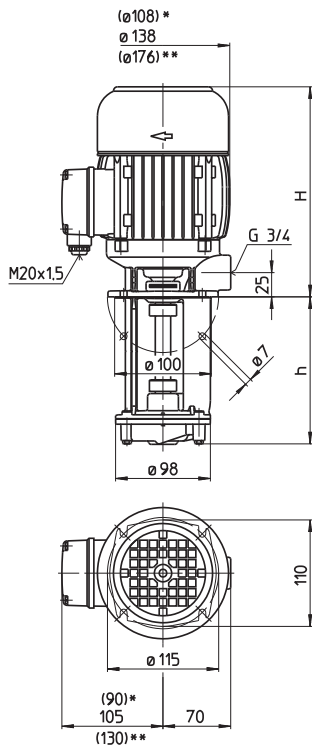

#### TM24, 26

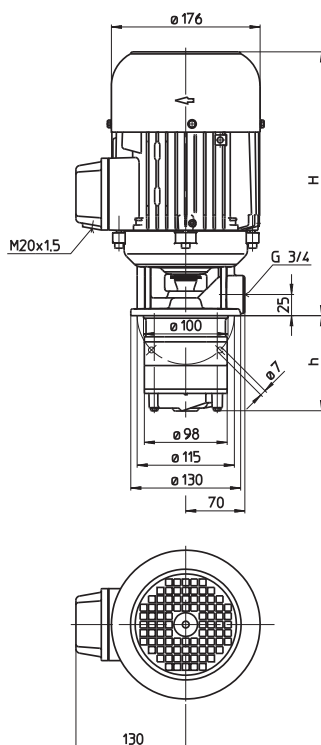

\*) Dimensions for TS12, 13

\*\*\*) Dimensions for TS24

Type	Vol. del. at manom. del. head l/min /m	Height H mm	Depth of immersion h mm	Weight kg	Power kW	Voltage 3~ V	Fre- quency Hz	Rated current A	Speed 1/min
<b>TS12/110</b>	20/10	178	110	5.4	0.27	220-240 380-420 460	50 50 60	1.10 0.63 0.63	2800 2800 3300
<b>150</b>			150	5.6					
<b>190</b>			190	5.8					
<b>250</b>			250	6.1					
<b>300</b>			300	6.5					
<b>TS13/110</b>	20/15	211	110	6.3	0.4	220-240 380-420 460	50 50 60	1.55 0.90 0.90	2700 2700 3200
<b>150</b>			150	6.5					
<b>190</b>			190	6.7					
<b>250</b>			250	7.0					
<b>300</b>			300	7.4					
<b>TS21/110</b>	40/15	217	110	7.8	0.63	220-240 380-420 460	50 50 60	2.6 1.5 1.5	2750 2750 3250
<b>150</b>			150	8.0					
<b>190</b>			190	8.2					
<b>250</b>			250	8.5					
<b>300</b>			300	8.9					
<b>350</b>			350	9.3					
<b>TS22/110</b>	40/25	235	110	9.7	0.92	220-240 380-420 460	50 50 60	4.7 2.7 2.7	2700 2700 3300
<b>150</b>			150	9.9					
<b>190</b>			190	10.1					
<b>250</b>			250	10.4					
<b>300</b>			300	10.8					
<b>350</b>			350	11.2					
<b>TS24/140</b>	40/35	300	140	20	1.7	220-240 380-420 460	50 50 60	7.1 4.1 4.1	2850 2850 3400
<b>180</b>			180	21					
<b>220</b>			220	22					
<b>TM24/110</b>	20/65	313	110	21	1.7	220-240 380-420 460	50 50 60	7.1 4.1 4.1	2850 2850 3400
<b>150</b>			150	22					
<b>TM26/140</b>	20/100	348	140	28	2.6	220-240 380-420 460	50 50 60	10.9 6.3 6.3	2850 2850 3400
<b>180</b>			180	29					



### Immersion Pumps

Models TS12 to TM26 are suitable for **CNC machine tools** featuring coolant supply through the tool holder or driving spindle or equipped with internally cooled tool.

These pumps are equipped with a peripheral impeller to achieve a compact high pressure unit.

Series TS/TM are suitable for filtered coolant only.

To reduce pump pressure, models TS22 to TM26 are also available with an optional Y/YY (Dahlander) motor configuration for 4 pole operation at half speed.

 Special versions of the TS pumps can be supplied for use with temperature controlling systems carrying thermal oils of up to 150° C resp. 200° C.

### Applications

#### Types of fluid

water  
coolants  
cooling/cutting oils

#### Kinematic viscosity

...90 mm<sup>2</sup>/s (90 cSt)

#### Pumping temperature

0...80° C  
...150° C (200° C) as special make (TS)

### Construction

Pump body	cast iron
Cover	cast iron
Impellers	brass
Shaft	steel
Mechanical seal	graphite based (TM)

#### Optional:

Pump body	bronze (TS12...TS22)
Cover	bronze (TS12...TS22)
Impellers	CrNi-steel (TS12...TS22)

#### Noise level

TS12...TS13	54 dBA
TS21...TS22	64 dBA
TM24...TM26	66 dBA
TS24	67 dBA

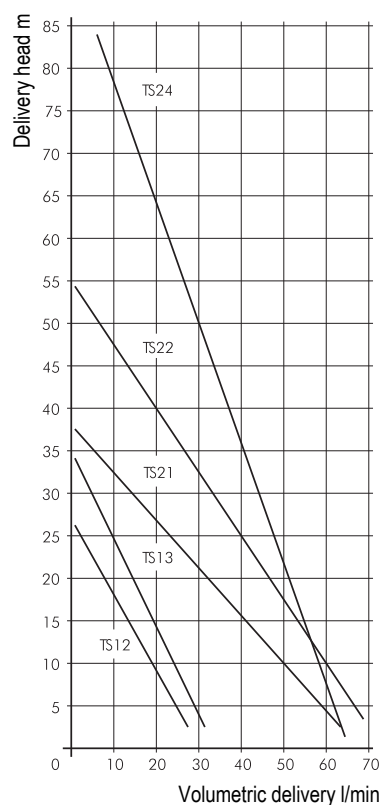
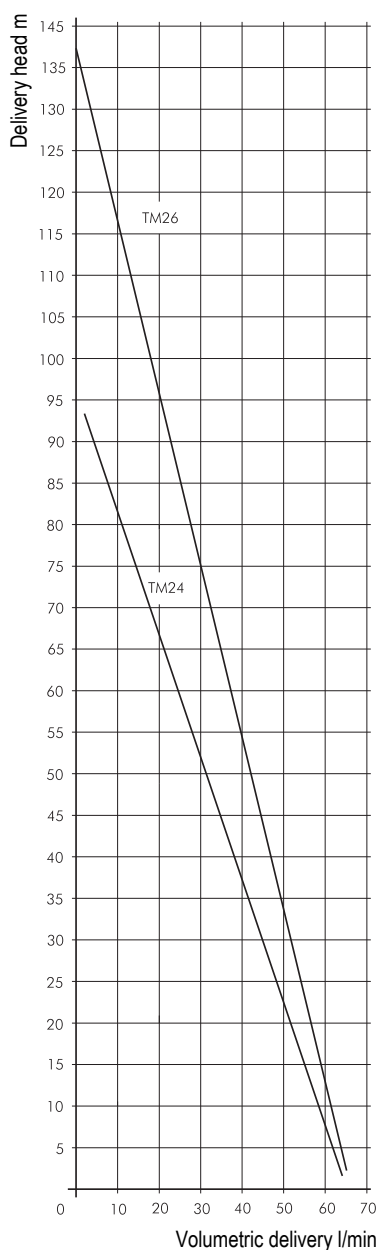

# Immersion Pumps

## TC25

### Closed impellers

#### TC25/260...805

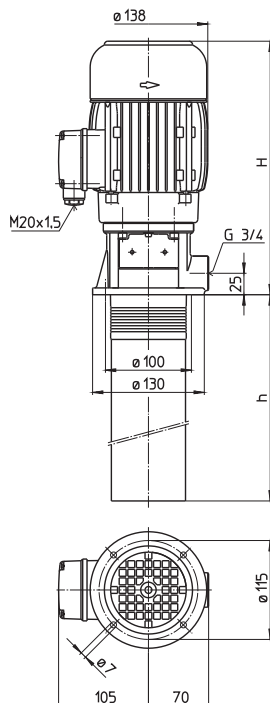

#### TC25/810

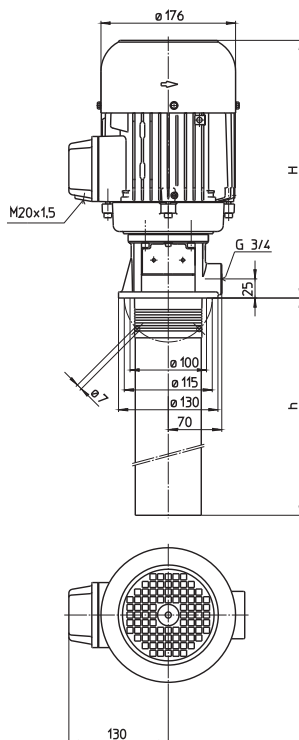

Type	Vol. del. at manom. del. head l/min / m	Height H mm	Depth of im- mersion h mm	Weight kg	Power kW	Voltage 3 ~ V	Fre- quency Hz	Rated current A	Speed 1/min
<b>TC25/260</b>	10/28	276	260	9.5	0.38	220-240 380-420 460	50 50 60	1.75 1.00 1.00	2750 2750 3250
<b>TC25/340</b>	10/45	276	335	11.5	0.5	220-240 380-420 460	50 50 60	2.42 1.40 1.40	2800 2800 3300
<b>TC25/430</b>	10/63	276	430	12.5	0.63	220-240 380-420 460	50 50 60	2.6 1.5 1.5	2750 2750 3250
<b>TC25/550</b>	10/85	314	565	15.5	1.1	220-240 380-420 460	50 50 60	5.0 2.9 2.9	2700 2700 3300
<b>TC25/805</b>	10/110	314	810	18	1.2	220-240 380-420 460	50 50 60	4.7 2.7 2.7	2750 2750 3250
<b>TC25/810</b>	10/140	337	810	26	1.3	220-240 380-420 460	50 50 60	5.2 3.0 3.0	2850 2850 3400

### Immersion Pumps

Our multistage pump models TC25...TC460 have been especially developed to supply **internally cooled tools** with coolant fluid.

**Closed impellers** provide optimal hydraulic efficiencies while minimizing power consumption.

For alternating machining using **internally** and **externally cooled tools**, these models are available with Y/YY-configured **pole-changing motor** (Dahlander) for optional changeover to **half speed** operation.

**A frequency converter** can be supplied for **special applications** or for matching the pump characteristic to a specific duty point.

See page "Control/Regulation" in the Technical Information section of this catalog for further information.

**Extended length is possible.** See mechanical/hydraulic features within the technical information section.

### Applications

- Types of fluid  
 water  
 coolants  
 cooling/cutting oils
- Kinematic viscosity  
 ...25 mm<sup>2</sup>/s (25 cSt)
- Pumping temperature  
 0...60° C

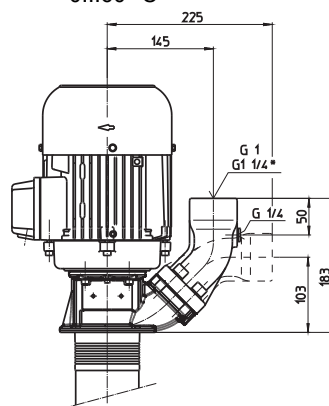

Upon request  
 all STC pumps are available with an SAE flange  
 \*) Dimensions STC160

### Construction

Pump body	cast iron
Pump shell	steel
Cover	PBTP
Intake strainer	steel
Impellers	PBTP
Shaft	steel
Mechanical seal	SiC
O-rings	Viton
Optional:	
Pole-changing motor	4 - 2 poles
Pump body	bronze CrNi-steel
Noise level	
TC25/260...TC25/805	58 dBA
TC25/810	63 dBA

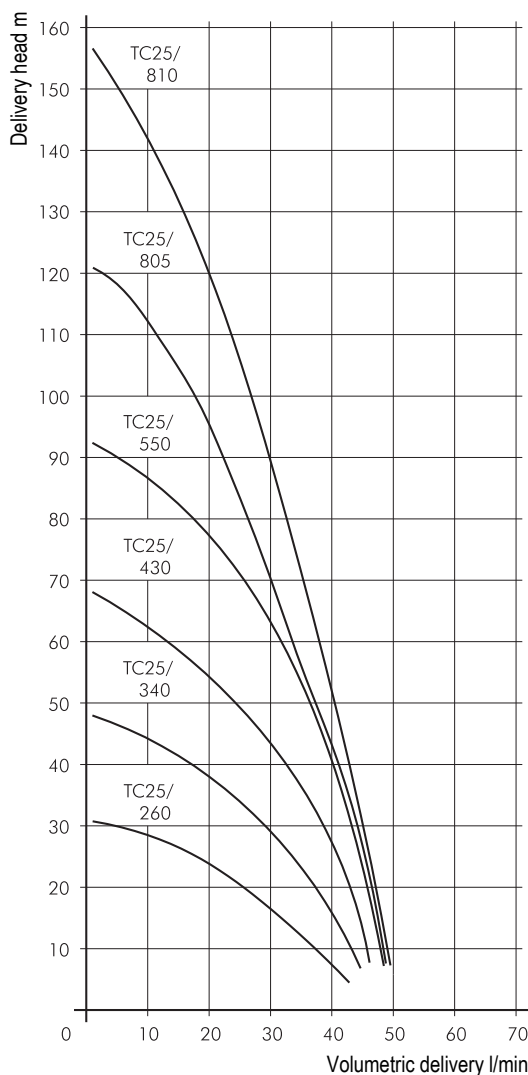

## TC40

### Closed impellers

#### TC40/260...550

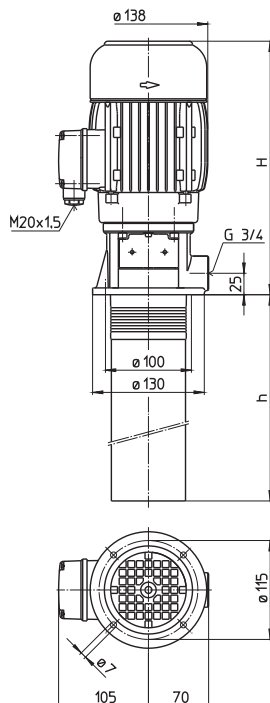

#### TC40/715...720

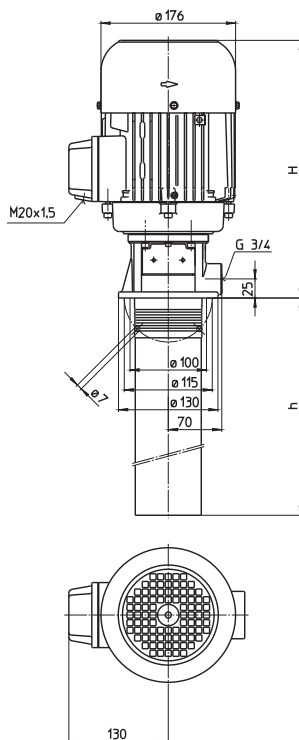

Type	Vol. del. at manom. del. head l/min / m	Height H mm	Depth of im- mersion h mm	Weight kg	Power kW	Voltage 3 ~ V	Fre- quency Hz	Rated current A	Speed 1/min
<b>TC40/260</b>	25/27	276	260	10	0.42	220-240 380-420 460	50 50 60	1.4 0.8 0.8	2800 2800 3300
<b>TC40/340</b>	25/40	276	335	11.5	0.5	220-240 380-420 460	50 50 60	2.42 1.40 1.40	2800 2800 3300
<b>TC40/430</b>	25/60	294	430	13.5	0.85	220-240 380-420 460	50 50 60	4.3 2.5 2.5	2800 2800 3300
<b>TC40/550</b>	25/80	314	550	15.5	1.1	220-240 380-420 460	50 50 60	5.0 2.9 2.9	2700 2700 3300
<b>TC40/715</b>	25/95	337	720	24	1.5	220-240 380-420 460	50 50 60	6.6 3.8 3.8	2850 2850 3400
<b>TC40/720</b>	25/120	337	720	25	1.7	220-240 380-420 460	50 50 60	7.1 4.1 4.1	2850 2850 3400

### Immersion Pumps

Our multistage pump models TC25...TC460 have been especially developed to supply **internally cooled tools** with coolant fluid.

**Closed impellers** provide optimal hydraulic efficiencies while minimizing power consumption.

For alternating machining using **internally** and **externally cooled tools**, these models are available with Y/YY-configured **pole-changing motor** (Dahlander) for optional changeover to **half speed** operation.

**A frequency converter** can be supplied for **special applications** or for matching the pump characteristic to a specific duty point.

See page "Control/Regulation" in the Technical Information section of this catalog for further information.

**Extended length is possible.** See mechanical/hydraulic features within the technical information section.

### Applications

- Types of fluid  
 water  
 coolants  
 cooling/cutting oils
- Kinematic viscosity  
 ...25 mm<sup>2</sup>/s (25 cSt)
- Pumping temperature  
 0...60° C

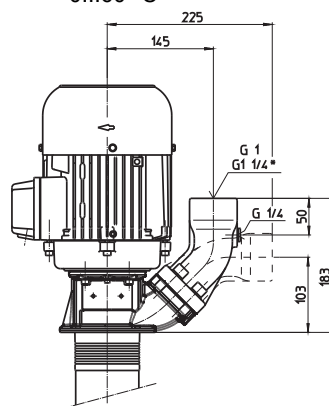

Upon request  
 all STC pumps are available with an SAE flange  
 \*) Dimensions STC160

### Construction

Pump body	cast iron
Pump shell	steel
Cover	PBTP
Intake strainer	steel
Impellers	PBTP
Shaft	steel
Mechanical seal	SiC
O-rings	Viton
Optional:	
Pole-changing motor	4 - 2 poles
Pump body	bronze CrNi-steel
Noise level	
TC40/260...TC40/550	58 dBA
TC40/715...TC40/720	63 dBA

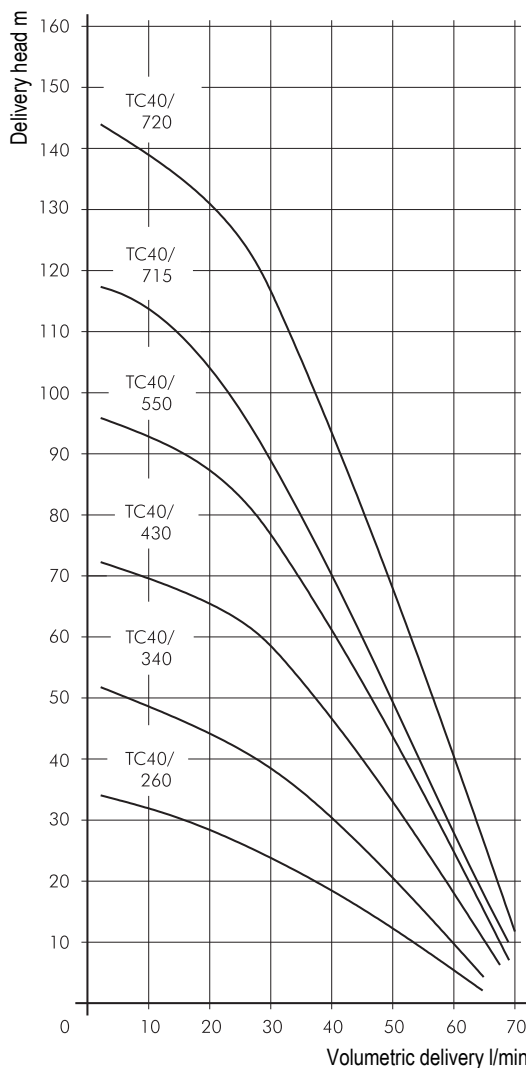

## TC63

### Closed impellers

#### TC63/270...440

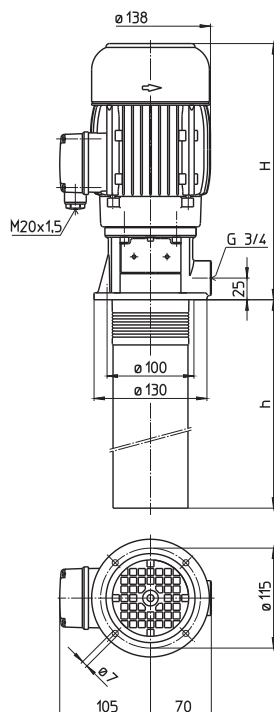

#### TC63/560...750

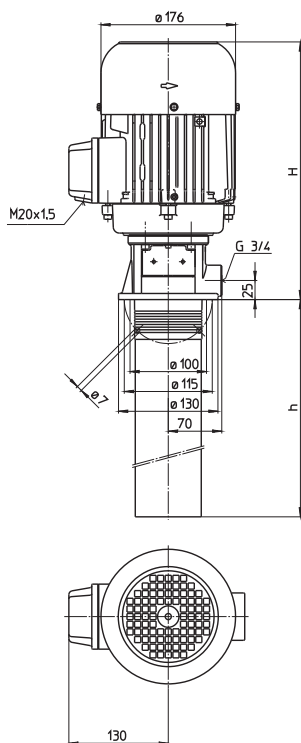

Type	Vol. del. at manom. del. head l/min / m	Height H mm	Depth of im- mersion h mm	Weight kg	Power kW	Voltage 3 ~ V	Fre- quency Hz	Rated current A	Speed 1/min
<b>TC63/270</b>	60/20	276	275	11	0.63	220-240 380-420 460	50 50 60	2.6 1.5 1.5	2750 2750 3250
<b>TC63/350</b>	60/30	294	340	13	0.85	220-240 380-420 460	50 50 60	4.3 2.5 2.5	2800 2800 3300
<b>TC63/440</b>	60/40	314	440	15	1.1	220-240 380-420 460	50 50 60	5.0 2.9 2.9	2700 2700 3300
<b>TC63/560</b>	60/55	337	565	24	1.7	220-240 380-420 460	50 50 60	7.1 4.1 4.1	2850 2850 3400
<b>TC63/745</b>	60/77	377	755	27	1.9	220-240 380-420 460	50 50 60	8.5 4.9 4.9	2850 2850 3400
<b>TC63/750</b>	60/90	387	755	30	2.6	220-240 380-420 460	50 50 60	10.9 6.3 6.3	2850 2850 3400

### Immersion Pumps

Our multistage pump models TC25...TC460 have been especially developed to supply **internally cooled tools** with coolant fluid.

**Closed impellers** provide optimal hydraulic efficiencies while minimizing power consumption.

For alternating machining using **internally** and **externally cooled tools**, these models are available with Y/YY-configured **pole-changing motor** (Dahlander) for optional changeover to **half speed** operation.

**A frequency converter** can be supplied for **special applications** or for matching the pump characteristic to a specific duty point.

See page "Control/Regulation" in the Technical Information section of this catalog for further information.

**Extended length is possible.** See mechanical/hydraulic features within the technical information section.

### Applications

- Types of fluid  
 water  
 coolants  
 cooling/cutting oils
- Kinematic viscosity  
 ...90 mm<sup>2</sup>/s (90 cSt)
- Pumping temperature  
 0...60° C

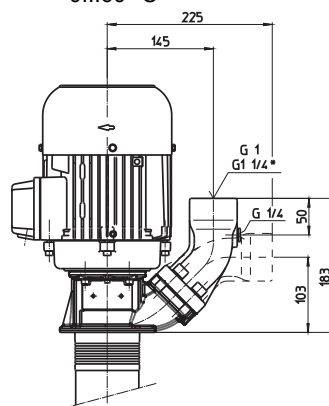

Upon request  
 all STC pumps are available with an SAE flange  
 \*) Dimensions STC160

### Construction

Pump body	cast iron
Pump shell	steel
Cover	PBTP
Intake strainer	steel
Impellers	PBTP
Shaft	steel
Mechanical seal	SiC
O-rings	Viton
Optional:	
Pole-changing motor	4 - 2 poles
Pump body	bronze CrNi-steel
Noise level	
TC63/270...TC63/440	58 dBA
TC63/560...TC63/750	63 dBA

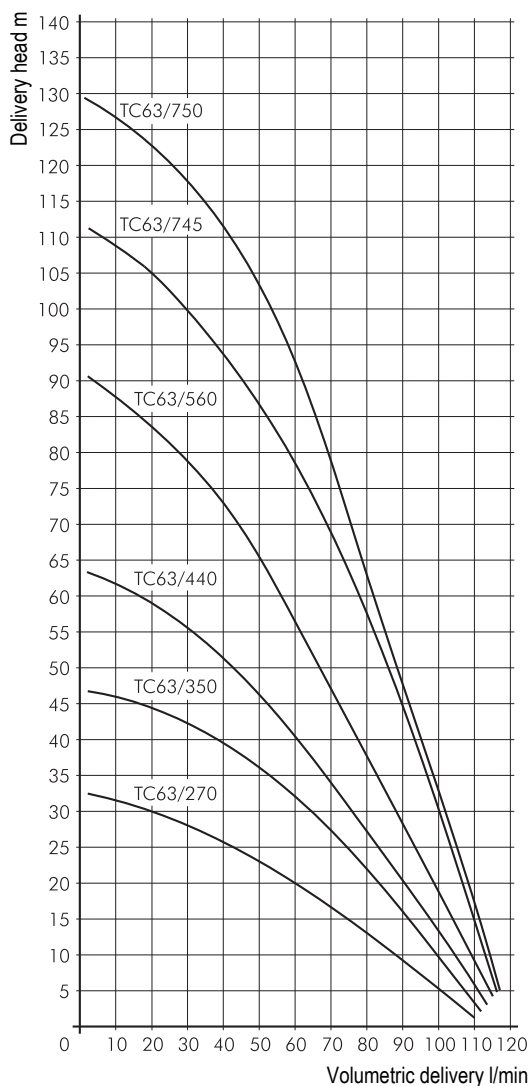

## TC160

### Closed impellers

#### TC160/330...740

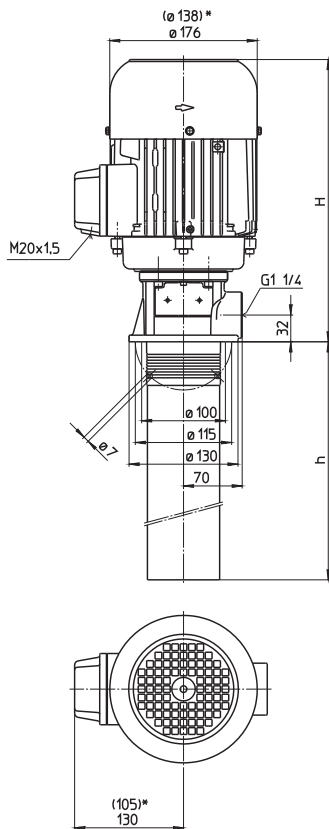

\*) Dimensions for TC160/330

Type	Vol. del. at manom. del. head l/min /m	Height H mm	Depth of im- mersion h mm	Weight kg	Power kW	Voltage 3 ~ V	Fre- quency Hz	Rated current A	Speed 1/min
<b>TC160/330</b>	160/15	314	325	14	1.1	220-240 380-420 460	50 50 60	5.0 2.9 2.9	2700 2700 3300
<b>TC160/430</b>	160/27	337	425	22	1.7	220-240 380-420 460	50 50 60	7.1 4.1 4.1	2850 2850 3400
<b>TC160/580</b>	160/40	377	580	27	2.2	220-240 380-420 460	50 50 60	9.2 5.3 5.3	2850 2850 3400
<b>TC160/740</b>	160/52	387	735	29	2.6	220-240 380-420 460	50 50 60	10.9 6.3 6.3	2850 2850 3400



### Immersion Pumps

Our multistage pump models TC25...TC460 have been especially developed to supply **internally cooled tools** with coolant fluid.

**Closed impellers** provide optimal hydraulic efficiencies while minimizing power consumption.

For alternating machining using **internally** and **externally cooled tools**, these models are available with Y/YY-configured **pole-changing motor** (Dahlander) for optional changeover to **half speed** operation.

**A frequency converter** can be supplied for **special applications** or for matching the pump characteristic to a specific duty point.

See page "Control/Regulation" in the Technical Information section of this catalog for further information.

**Extended length is possible.** See mechanical/hydraulic features within the technical information section.

### Applications

- Types of fluid  
 water  
 coolants  
 cooling/cutting oils
- Kinematic viscosity  
 ...90 mm<sup>2</sup>/s (90 cSt)
- Pumping temperature  
 0...60° C

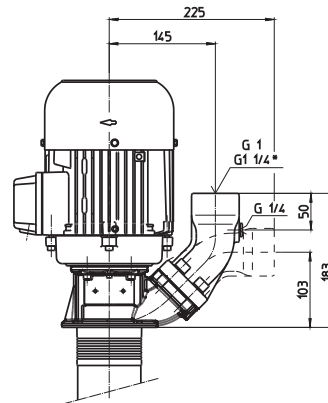

Upon request  
 all STC pumps are available with an SAE flange  
 \*) Dimensions STC160

### Construction

Pump body	cast iron
Pump shell	steel
Cover	PBTP
Intake strainer	steel
Impellers	PBTP
Shaft	steel
Mechanical seal	SiC
O-rings	Viton
Optional:	
Pole-changing motor	4 - 2 poles
Pump body	bronze CrNi-steel
Noise level	
TC160/330	58 dBA
TC160/430...TC160/740	63 dBA

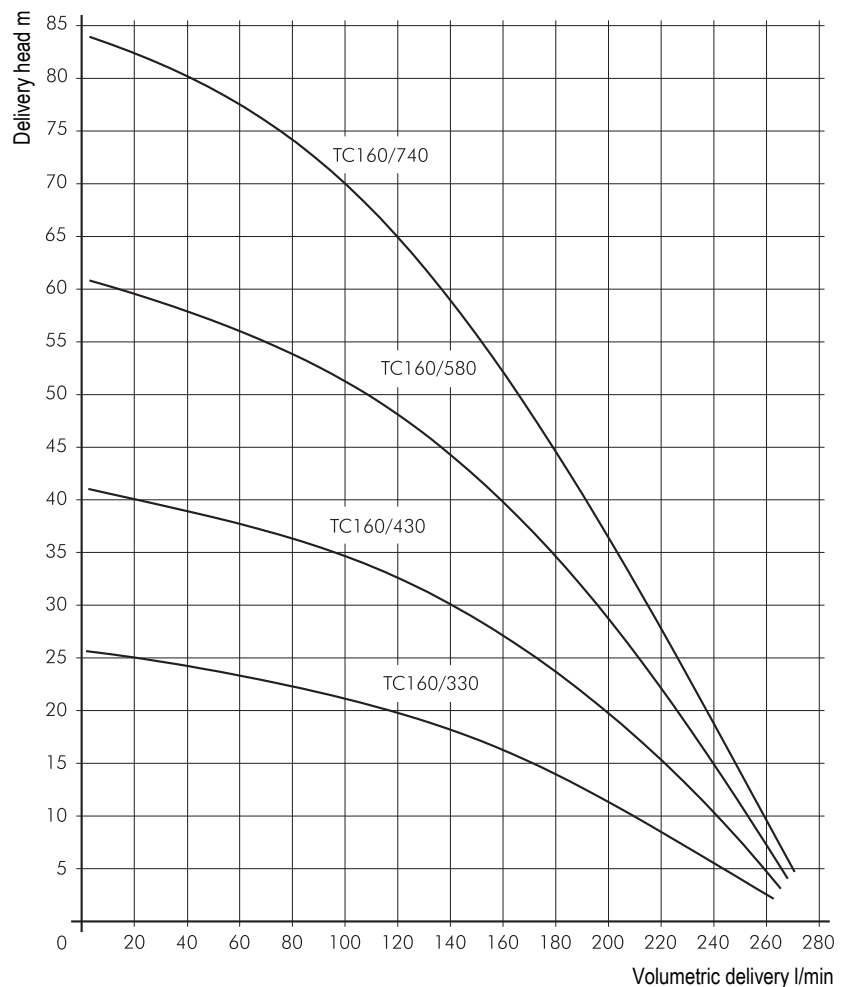

# Immersion Pumps TH

## Pressure Boosting Pumps FH

### Closed impellers

Series TH and FH use closed impellers in order to minimize power consumption and to optimize hydraulic pump efficiencies. In addition, the TH series offers high pressures at short immersion depths.

Inline pumps of the series FH can be used as boosting pumps if provided with positive inlet pressure. This inlet pressure can be provided by the central coolant supply or a feed pump. In such a setup, pumps of the series FH can raise the incoming pressure by up to 26 bar.

For alternating machining using **internally** and **externally cooled tools**, these models are available with Y/Y- configured **polechanging motor** (Dahlander) for optional changeover to half speed operation.

A **frequency converter** can be supplied for **special applications** or for matching the pump characteristic to a specific duty point. See page "Control/Regulation" in the Technical Information section of this catalog for further information.



TH



FH

#### Applications

Types of fluid  
 water  
 coolants  
 cooling/cutting oils  
 Kinematic viscosity  
 ...25 mm<sup>2</sup>/s (25 cSt) TH/FH  
 Pumping temperature  
 0...80° C

#### Construction

Pump body	cast iron
Cover	cast iron
Impellers	CrNi-steel
Diffusers	CrNi-steel
Shaft	CrNi-steel
Mechanical seal	SiC
O-rings	Viton

Optional  
 Pole-changing motor 4 - 2 poles  
 Pump body + cover in bronze

For position of terminal box, see technical information mechanical.

#### Pump Curves

One key feature of the TH/FH series pumps is their non-overloading motors. These pumps can be operated across the entire pump curve without damaging the motor. This key advantage applies for all allowed fluids, including coolant oils. For specific applications where only one working point is required, the pump/motor combinations can be reviewed and a smaller motor size might be applicable.

#### Number of Stages

TH/FH pump curves are determined by the number of impeller used within the pump.

Within the range the immersion depth can be extend up to the maximum mentioned length.

Example: TH203A890 (3 impeller, 890mm immersion length)

#### Type Designation

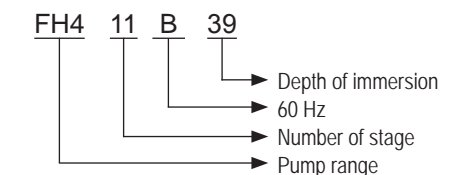
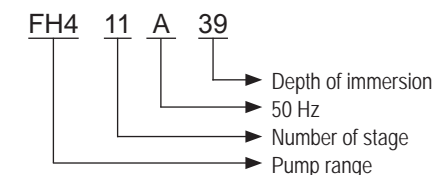
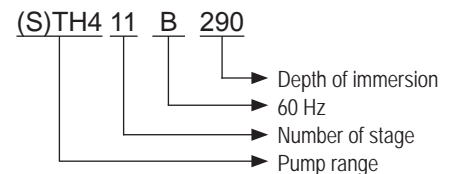
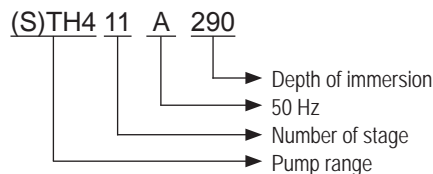

#### SAE Flange for TH Pumps

Upon request all TH pumps are available with an SAE flange.

The flange allows for either vertical or horizontal pipe connection and offers a G 1/4 pressure gauge connection port.

A surcharge applies for pumps ordered with SAE flange.

# Immersion Pumps TH

## Pressure Boosting Pumps FH

### Closed impellers

#### Applying TH/FH pumps in grinding applications

Grinding versions TH/FH pumps (-E). TH/FH series pumps can be supplied upon request in a special grinding version for applications with heavy loads of abrasive particles (>50HRC).  
Ordering description: e.g. TH224A590-E

In this version pumps are supplied without internal diffusor gaskets in order to prevent increased wear caused by the abrasive particles in the fluid. As a result, however, the internal losses of the pump increase and the pump curves are reduced by the following percentages (valid for water based coolants).

The grinding version cause lower pump curves. These curves are available upon request.

#### Examples for pressure boosting: TH632A890 + FH632A89 in tandem-arrangement

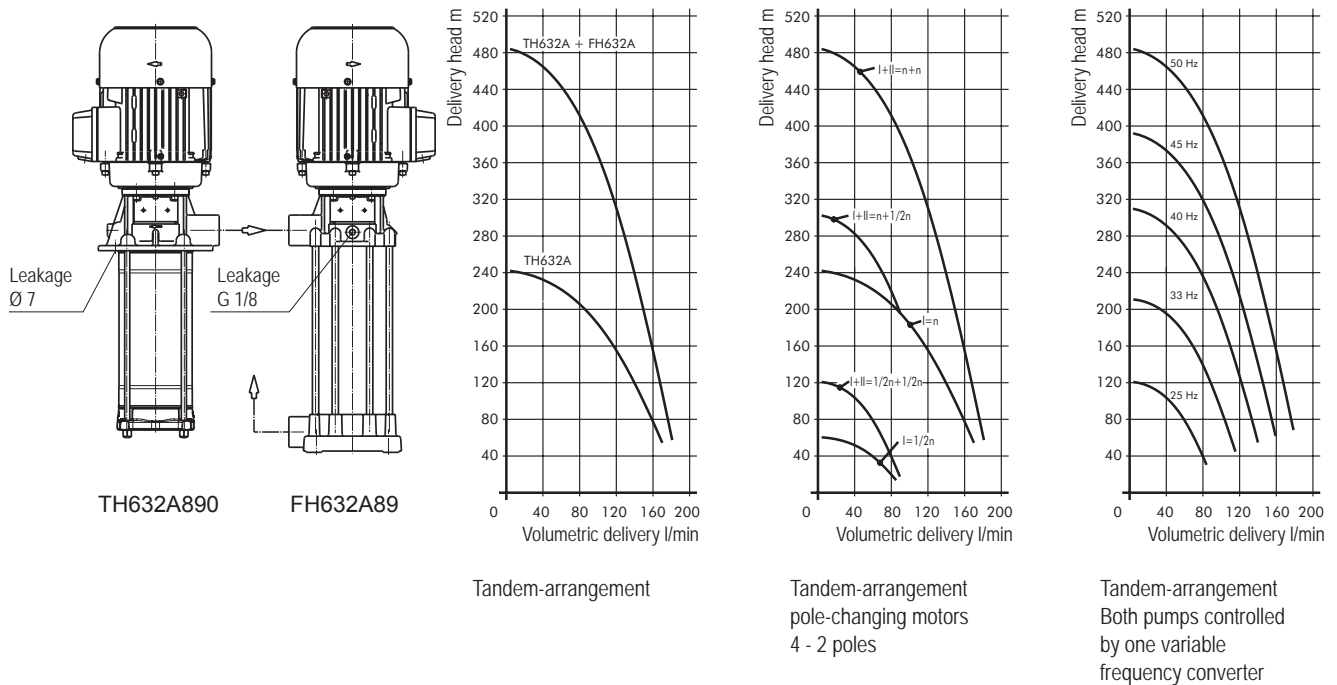

#### Examples for pressure boosting: FH616A49 + 4 bar of positive head from central coolant supply

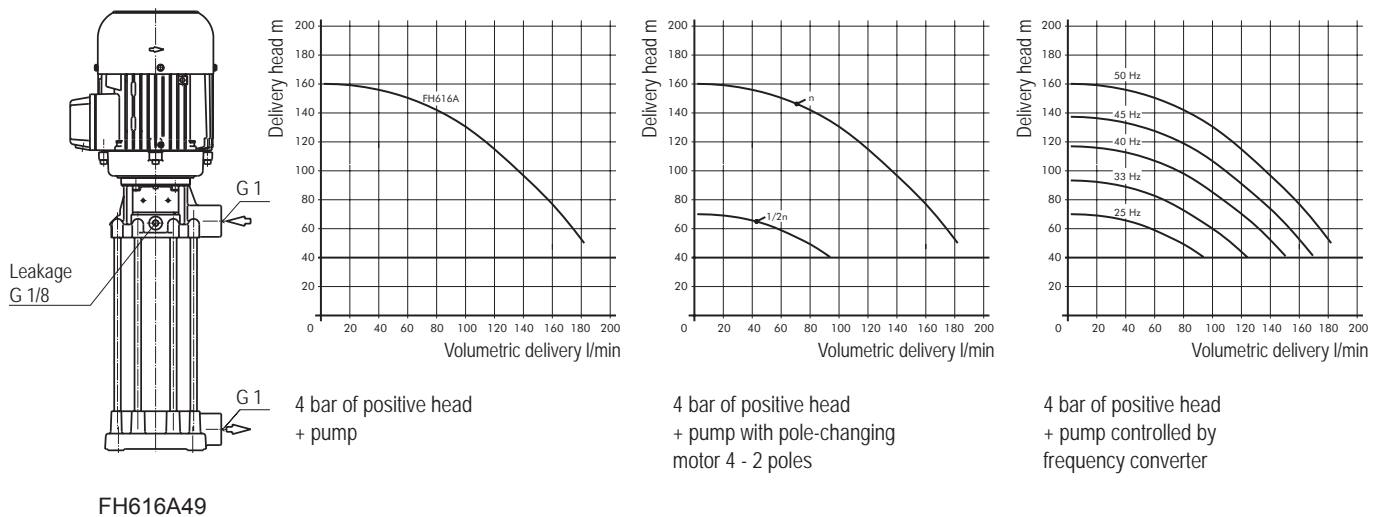

# Immersion Pumps



## (S)TH2

Closed impellers

50 Hz

### TH203...241

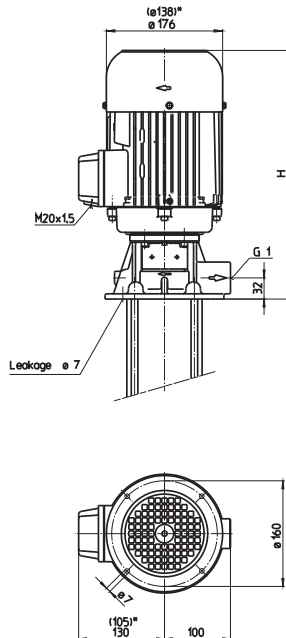

### STH203...241

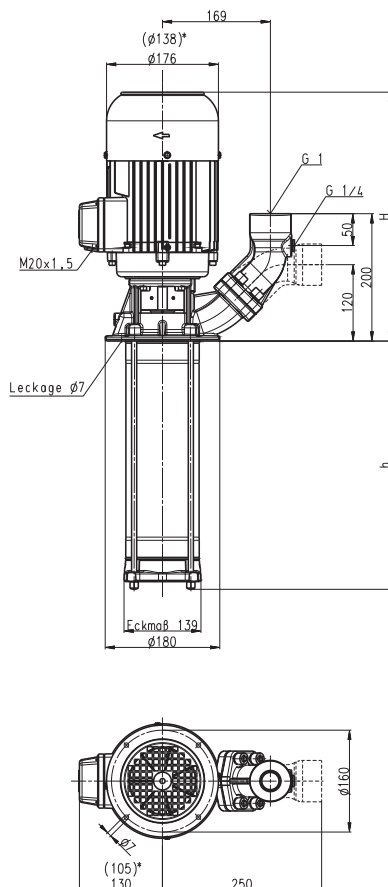

\*) Dimensions for (S)TH203...(S)TH223

Type	Vol. del. at manom. del. head l/min / m	Height H mm	Depth of immersion h mm	Weight kg	Power kW	Voltage 3~ V	Fre- quency Hz	Rated current A	Speed 1/min
(S)TH203A190	20/15	291	190	14.4	0.45	220-240 380-420	50 50	1.9 1.1	2800 2800
(S)TH204A190	20/20			14.5					
(S)TH205A190	20/25			14.6					
(S)TH206A190	20/30			14.7					
(S)TH207A290	20/35		290	15.2					
(S)TH208A290	20/40	291	290	15.6	0.54	220-240 380-420	50 50	2.42 1.40	2800 2800
(S)TH209A290	20/45			15.7					
(S)TH210A290	20/50			15.8					
(S)TH211A290	20/56			15.9					
(S)TH212A390	20/60	309	390	18.1	0.75	220-240 380-420	50 50	3.8 2.2	2700 2700
(S)TH213A390	20/68			18.2					
(S)TH214A390	20/75			18.3					
(S)TH215A390	20/82	309	390	19.2	0.92	220-240 380-420	50 50	4.7 2.7	2700 2700
(S)TH216A390	20/88			19.3					
(S)TH217A490	20/93		490	19.8					
(S)TH218A490	20/98			19.9					
(S)TH219A490	20/102	329	490	20.9	1.1	220-240 380-420	50 50	5.0 2.9	2700 2700
(S)TH220A490	20/108			21.0					
(S)TH221A490	20/112			21.1					
(S)TH222A590	20/118		590	21.6					
(S)TH223A590	20/125			21.7					
(S)TH224A590	20/130	352	590	29.0	1.3	220-240 380-420	50 50	5.2 3.0	2850 2850
(S)TH225A590	20/135			29.1					
(S)TH226A590	20/142	352	590	29.7	1.5	220-240 380-420	50 50	6.6 3.8	2850 2850
(S)TH227A690	20/150		690	30.2					
(S)TH228A690	20/155			30.3					
(S)TH229A690	20/160	352	690	30.8	1.7	220-240 380-420	50 50	7.1 4.1	2850 2850
(S)TH230A690	20/166			30.9					
(S)TH231A690	20/172			31.0					
(S)TH232A790	20/178		790	31.5					
(S)TH233A790	20/182			31.6					
(S)TH234A790	20/190	376	790	35.6	1.9	220-240 380-420	50 50	8.5 4.9	2850 2850
(S)TH235A790	20/195			35.7					
(S)TH236A790	20/200			35.8					
(S)TH237A890	20/205	376	890	36.8	2.2	220-240 380-420	50 50	9.2 5.3	2850 2850
(S)TH238A890	20/210			36.9					
(S)TH239A890	20/215			37.0					
(S)TH240A890	20/220			37.1					
(S)TH241A890	20/225			37.2					

**Immersion Pumps**

series TH and FH use **closed impellers** in order to minimize power consumption and to optimize hydraulic pump efficiencies. In addition, the TH series offers high pressures at short immersion depths. Inline pumps of the series FH can be used as **boosting pumps** if provided with positive inlet pressure. This inlet pressure can be provided by the central coolant supply or a feed pump. In such a setup, pumps of the series FH can raise the incoming pressure by up to 26 bar.

**Extended length is possible.** See mechanical/hydraulic features within the technical information section.

**Applications**

Types of fluid  
 water  
 coolants  
 cooling/cutting oils  
 Kinematic viscosity  
 ...25 mm<sup>2</sup>/s (25 cSt)  
 Pumping temperature  
 0...80° C

**Construction**

Pump body	cast iron
Cover	cast iron
Impellers	CrNi-steel
Shaft	CrNi-steel
Diffusers	CrNi-steel
Mechanical seal	SiC
O-rings	Viton
Optional:	
Pole-changing motor	4 - 2 poles
Pump body	bronze
Cover	bronze
Noise level	
(S)TH203...(S)TH223	58 dBA
(S)TH224...(S)TH241	63 dBA

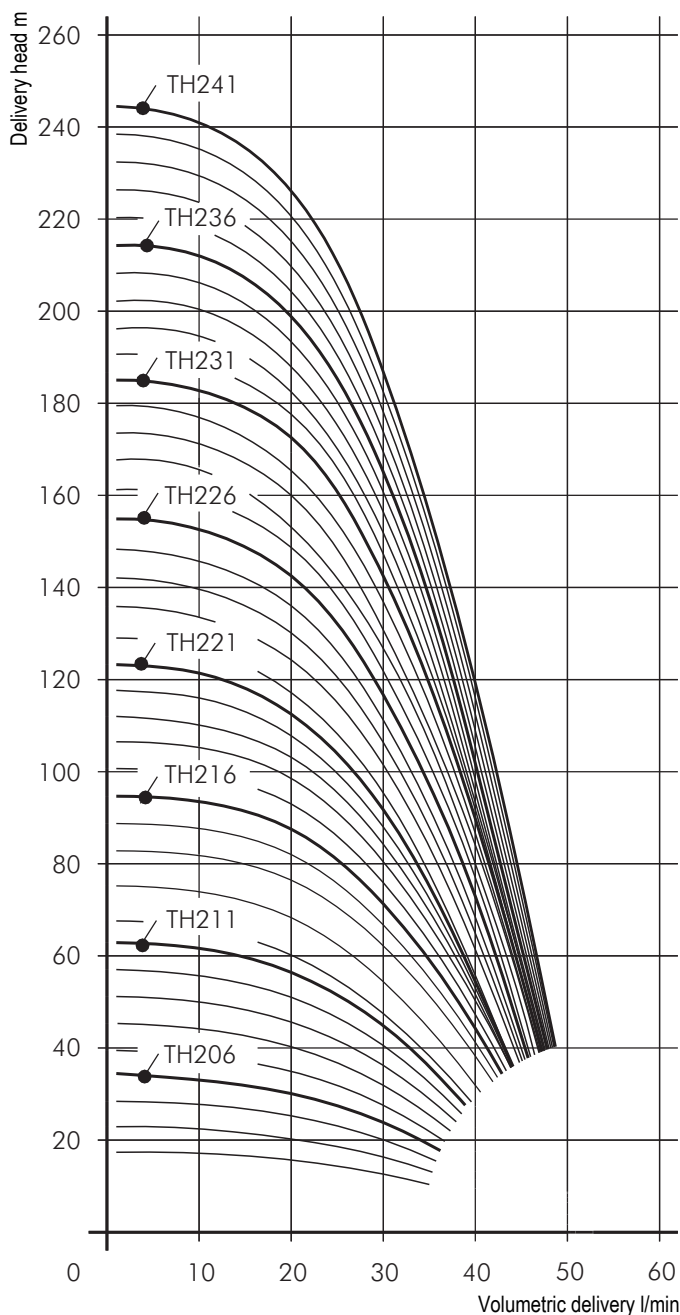

# Immersion Pumps



## (S)TH4

Closed impellers

50 Hz

### TH403...436

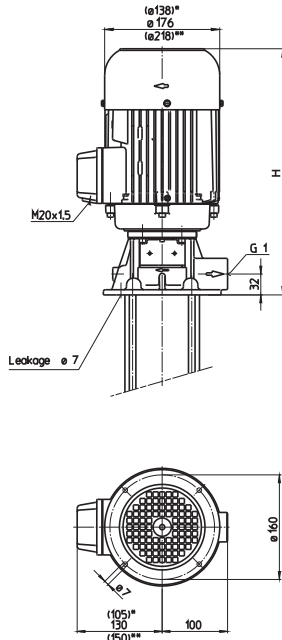

### STH403...436

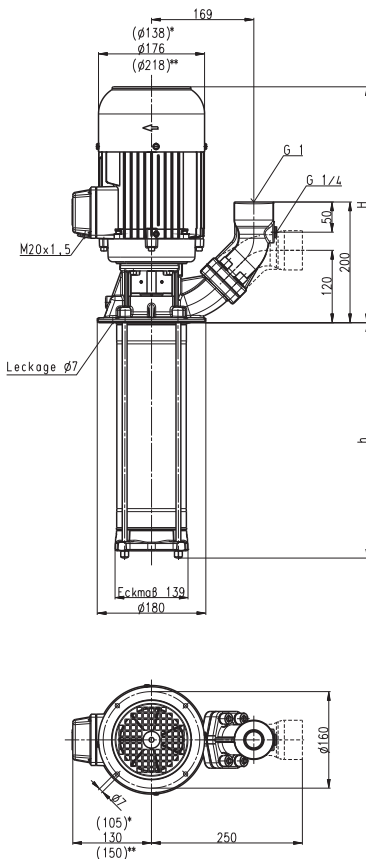

\*) Dimensions for (S)TH403...(S)TH413

\*\*) Dimensions for (S)TH414...(S)TH436

Type	Vol. del. at manom. del. head l/min / m	Height H mm	Depth of immersion h mm	Weight kg	Power kW	Voltage 3 ~ V	Fre- quency Hz	Rated current A	Speed 1/min
(S)TH403A190	40/18	291	190	14.4	0.45	220-240	50	1.9	2800
(S)TH404A190	40/25			14.5		380-420	50	1.1	2800
(S)TH405A190	40/30	291	190	14.9	0.54	220-240	50	2.42	2800
(S)TH406A190	40/36			15.0		380-420	50	1.40	2800
(S)TH407A290	40/42	309	290	17.8	0.75	220-240	50	3.8	2700
(S)TH408A290	40/50			17.9		380-420	50	2.2	2700
(S)TH409A290	40/56			18.0					
(S)TH410A290	40/62	309	290	19.0	0.92	220-240	50	4.7	2700
(S)TH411A290	40/68			19.1		380-420	50	2.7	2700
(S)TH412A390	40/74	329	390	20.5	1.1	220-240	50	5.0	2700
(S)TH413A390	40/80			20.6		380-420	50	2.9	2700
(S)TH414A390	40/86	352	390	27.9	1.3	220-240	50	5.2	2850
						380-420	50	3.0	2850
(S)TH415A390	40/95	352	390	28.5	1.5	220-240	50	6.6	2850
(S)TH416A390	40/104			28.6		380-420	50	3.8	2850
(S)TH417A490	40/112	352	490	29.1	1.7	220-240	50	7.1	2850
(S)TH418A490	40/118			29.2		380-420	50	4.1	2850
(S)TH419A490	40/125	376	490	33.3	1.9	220-240	50	8.5	2850
(S)TH420A490	40/130			33.4		380-420	50	4.9	2850
(S)TH421A490	40/136	376	490	34.0	2.2	220-240	50	9.2	2850
						380-420	50	5.3	2850
(S)TH422A590	40/142		590	34.5					
(S)TH423A590	40/150			34.6					
(S)TH424A590	40/156			34.7					
(S)TH425A590	40/162	386	590	35.3	2.6	220-240	50	10.9	2850
(S)TH426A590	40/168			35.4		380-420	50	6.3	2850
(S)TH427A690	40/175		690	36.0					
(S)TH428A690	40/182			36.1					
(S)TH429A690	40/190			36.2					
(S)TH430A690	40/198			36.3					
(S)TH431A690	40/208			36.4					
(S)TH432A790	40/216	441	790	47.0	3.3	220-240	50	13.8	2900
(S)TH433A790	40/220			47.1		380-420	50	8.0	2900
(S)TH434A790	40/230			47.2					
(S)TH435A790	40/240			47.3					
(S)TH436A790	40/248			47.4					

## Immersion Pumps

series TH and FH use **closed impellers** in order to minimize power consumption and to optimize hydraulic pump efficiencies. In addition, the TH series offers high pressures at short immersion depths. Inline pumps of the series FH can be used as **boosting pumps** if provided with positive inlet pressure. This inlet pressure can be provided by the central coolant supply or a feed pump. In such a setup, pumps of the series FH can raise the incoming pressure by up to 26 bar.

**Extended length is possible.** See mechanical/hydraulic features within the technical information section.

## Applications

Types of fluid  
 water  
 coolants  
 cooling/cutting oils  
 Kinematic viscosity  
 ...25 mm<sup>2</sup>/s (25 cSt)  
 Pumping temperature  
 0...80° C

## Construction

Pump body	cast iron
Cover	cast iron
Impellers	CrNi-steel
Shaft	CrNi-steel
Diffusers	CrNi-steel
Mechanical seal	SiC
O-rings	Viton
Optional:	
Pole-changing motor	4 - 2 poles
Pump body	bronze
Cover	bronze
Noise level	
(S)TH403...(S)TH413	58 dBA
(S)TH414...(S)TH431	63 dBA
(S)TH432...(S)TH436	71 dBA

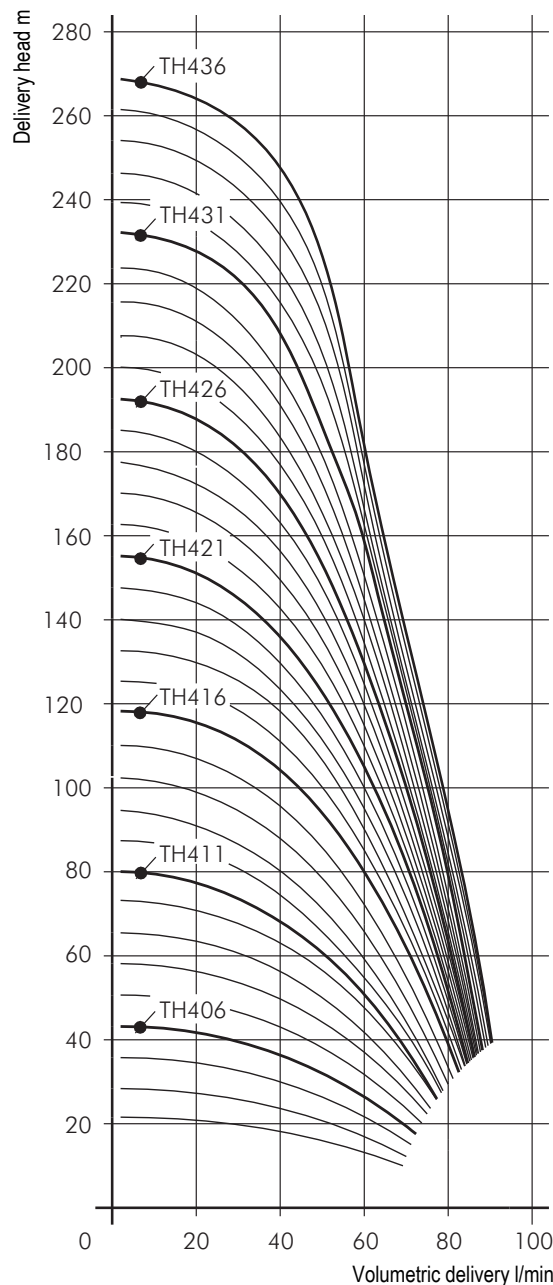



# Immersion Pumps



## (S)TH6

Closed impellers

50 Hz

### TH603...632

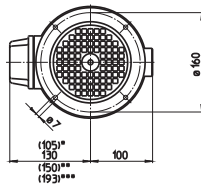
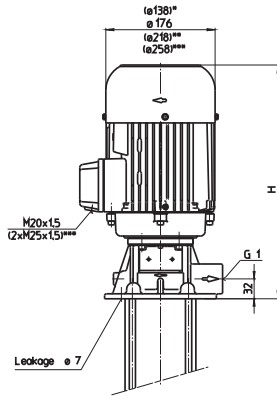

### STH603...632

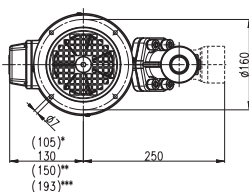
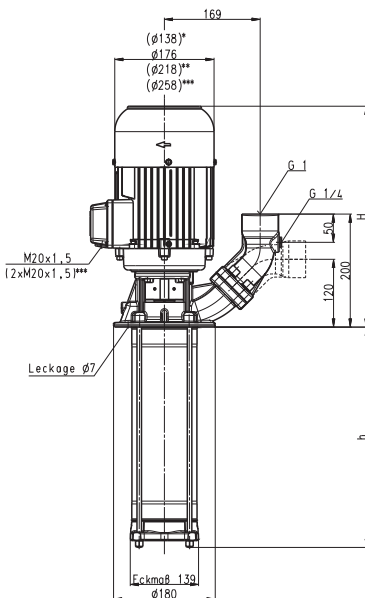

\*) Dimensions for (S)TH603...(S)TH608

\*\*) Dimensions for (S)TH619...(S)TH626

\*\*\*) Dimensions for (S)TH627...(S)TH632

Type	Vol. del. at manom. del. head l/min / m	Height H mm	Depth of immersion h mm	Weight kg	Power kW	Voltage 3 ~ V	Fre- quency Hz	Rated current A	Speed 1/min
(S)TH603A190	80/18	291	190	14.7	0.54	220-240 380-420	50 50	2.42 1.40	2800 2800
(S)TH604A190	80/24	309	190	16.5	0.75	220-240 380-420	50 50	3.8 2.2	2700 2700
(S)TH605A240	80/30		240	16.8					
(S)TH606A240	80/36	309	240	17.7	0.92	220-240 380-420	50 50	4.7 2.7	2700 2700
(S)TH607A290	80/41		290	18.0					
(S)TH608A290	80/48	329	290	19	1.1	220-240 380-420	50 50	5.0 2.9	2700 2700
(S)TH609A340	80/56	352	340	26.5	1.5	220-240 380-420	50 50	6.6 3.8	2850 2850
(S)TH610A340	80/61			26.6					
(S)TH611A390	80/71	352	390	30.9	1.7	220-240 380-420	50 50	7.1 4.1	2850 2850
(S)TH612A390	80/76	376	390	35	1.9	220-240 380-420	50 50	8.5 4.9	2850 2850
(S)TH613A490	80/82	376	490	35.5	2.2	220-240 380-420	50 50	9.2 5.3	2850 2850
(S)TH614A490	80/90			35.6					
(S)TH615A490	80/96			35.7					
(S)TH616A490	80/101	386	490	36.3	2.6	220-240 380-420	50 50	10.9 6.3	2850 2850
(S)TH617A590	80/108		590	36.8					
(S)TH618A590	80/114			40.0					
(S)TH619A590	80/120	441	590	50.6	3.3	220-240 380-420	50 50	13.8 8.0	2900 2900
(S)TH620A590	80/128			50.7					
(S)TH621A690	80/136		690	51.2					
(S)TH622A690	80/142			51.3					
(S)TH623A690	80/150	441	690	53.8	4.0	220-240 380-420	50 50	16.5 9.5	2900 2900
(S)TH624A690	80/155			53.9					
(S)TH625A790	80/160		790	54.5					
(S)TH626A790	80/166			54.6					
(S)TH627A790	80/172	477	790	71.2	5.0	220-240 380-420	50 50	20.8 12.0	2900 2900
(S)TH628A790	80/180			71.3					
(S)TH629A890	80/186		890	71.8					
(S)TH630A890	80/192			71.9					
(S)TH631A890	80/200			72.0					
(S)TH632A890	80/206			72.1					



## Immersion Pumps

series TH and FH use **closed impellers** in order to minimize power consumption and to optimize hydraulic pump efficiencies. In addition, the TH series offers high pressures at short immersion depths. Inline pumps of the series FH can be used as **boosting pumps** if provided with positive inlet pressure. This inlet pressure can be provided by the central coolant supply or a feed pump. In such a setup, pumps of the series FH can raise the incoming pressure by up to 26 bar.

**Extended length is possible.** See mechanical/hydraulic features within the technical information section.

## Applications

Types of fluid  
 water  
 coolants  
 cooling/cutting oils  
 Kinematic viscosity  
 ...25 mm<sup>2</sup>/s (25 cSt)  
 Pumping temperature  
 0...80° C

## Construction

Pump body	cast iron
Cover	cast iron
Impellers	CrNi-steel
Shaft	CrNi-steel
Diffusers	CrNi-steel
Mechanical seal	SiC
O-rings	Viton
Optional:	
Pole-changing motor	4 - 2 poles
Pump body	bronze
Cover	bronze
Noise level	
(S)TH603...(S)TH608	58 dBA
(S)TH609...(S)TH618	63 dBA
(S)TH619...(S)TH632	71 dBA

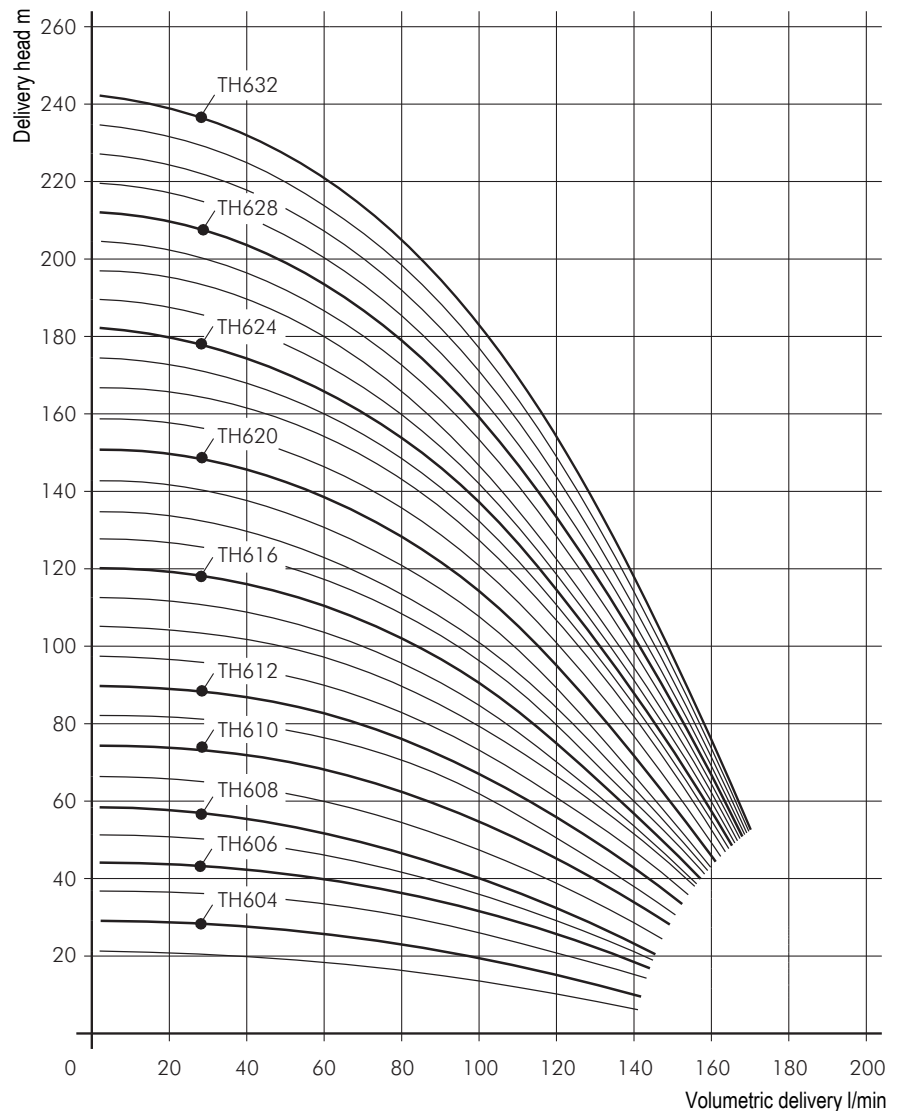

## (S)TH11

Closed impellers

50 Hz

### TH1102...1121

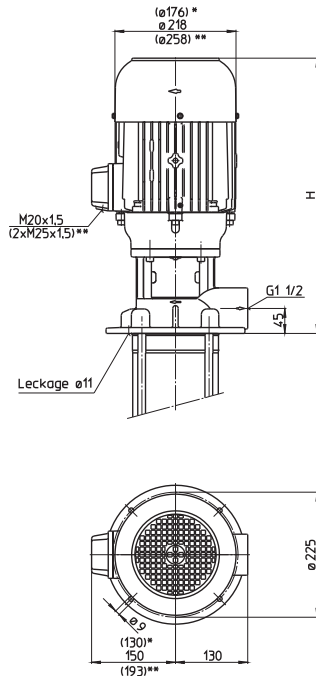

### STH1102...1121

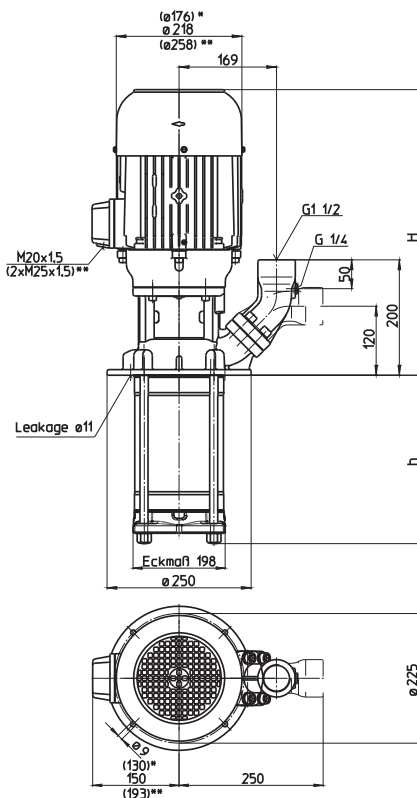

\*) Dimensions for (S)TH1102...1107

\*\*) Dimensions for (S)TH1111...1121

Type	Vol. del. at manom. del. head l/min / m	Height H mm	Depth of im- mersion h mm	Weight kg	Power kW	Voltage 3 ~ V	Fre- quency Hz	Rated current A	Speed 1/min
<b>(S)TH1102A180</b>	150/19	406	182	34	1.3	220-240 380-420	50 50	5.2 3.0	2850 2850
<b>(S)TH1103A180</b>	150/29	406	182	35	1.5	220-240 380-420	50 50	6.6 3.8	2850 2850
<b>(S)TH1104A280</b>	150/38		278	37					
<b>(S)TH1105A280</b>	150/48	431	278	41	1.9	220-240 380-420	50 50	8.5 4.9	2850 2850
<b>(S)TH1106A280</b>	150/58	431	278	42	2.2	220-240 380-420	50 50	9.2 5.3	2850 2850
<b>(S)TH1107A310</b>	150/67	441	310	44	2.6	220-240 380-420	50 50	10.9 6.3	2850 2850
<b>(S)TH1108A380</b>	150/78	496	374	55	3.3	220-240 380-420	50 50	13.8 8.0	2900 2900
<b>(S)TH1109A380</b>	150/88	496	374	58	4.0	220-240 380-420	50 50	16.5 9.5	2900 2900
<b>(S)TH1110A470</b>	150/98		470	60					
<b>(S)TH1111A470</b>	150/106	532	470	77	5.0	220-240 380-420	50 50	20.8 12.0	2900 2900
<b>(S)TH1112A470</b>	150/118			78					
<b>(S)TH1113A500</b>	150/128	532	502	79	5.5	220-240 380-420	50 50	22.0 12.5	2900 2900
<b>(S)TH1114A570</b>	150/138		566	81					
<b>(S)TH1115A570</b>	150/149	570	566	88	7.5	220-240 380-420	50 50	29 17	2900 2900
<b>(S)TH1116A660</b>	150/158		662	90					
<b>(S)TH1117A660</b>	150/168			91					
<b>(S)TH1118A660</b>	150/178			92					
<b>(S)TH1119A760</b>	150/188		758	93					
<b>(S)TH1120A760</b>	150/198			94					
<b>(S)TH1121A760</b>	150/206	620	758	109	10.0	220-240 380-420	50 50	40 23	2900 2900

## Immersion Pumps

series TH and FH use **closed impellers** in order to minimize power consumption and to optimize hydraulic pump efficiencies. In addition, the TH series offers high pressures at short immersion depths. Inline pumps of the series FH can be used as **boosting pumps** if provided with positive inlet pressure. This inlet pressure can be provided by the central coolant supply or a feed pump. In such a setup, pumps of the series FH can raise the incoming pressure by up to 26 bar.

**Extended length is possible.** See mechanical/hydraulic features within the technical information section.

## Applications

Types of fluid  
 water  
 coolants  
 cooling/cutting oils  
 Kinematic viscosity  
 ...25 mm<sup>2</sup>/s (25 cSt)  
 Pumping temperature  
 0...80° C

## Construction

Pump body	cast iron
Cover	cast iron
Impellers	CrNi-steel
Shaft	CrNi-steel
Diffusers	CrNi-steel
Mechanical seal	SiC
O-rings	Viton

Optional:  
 Pole-changing motor 4 - 2 poles

Noise level  
 (S)TH1102...(S)TH1107 63 dBA  
 (S)TH1108...(S)TH1114 71 dBA  
 (S)TH1115...(S)TH1121 74 dBA

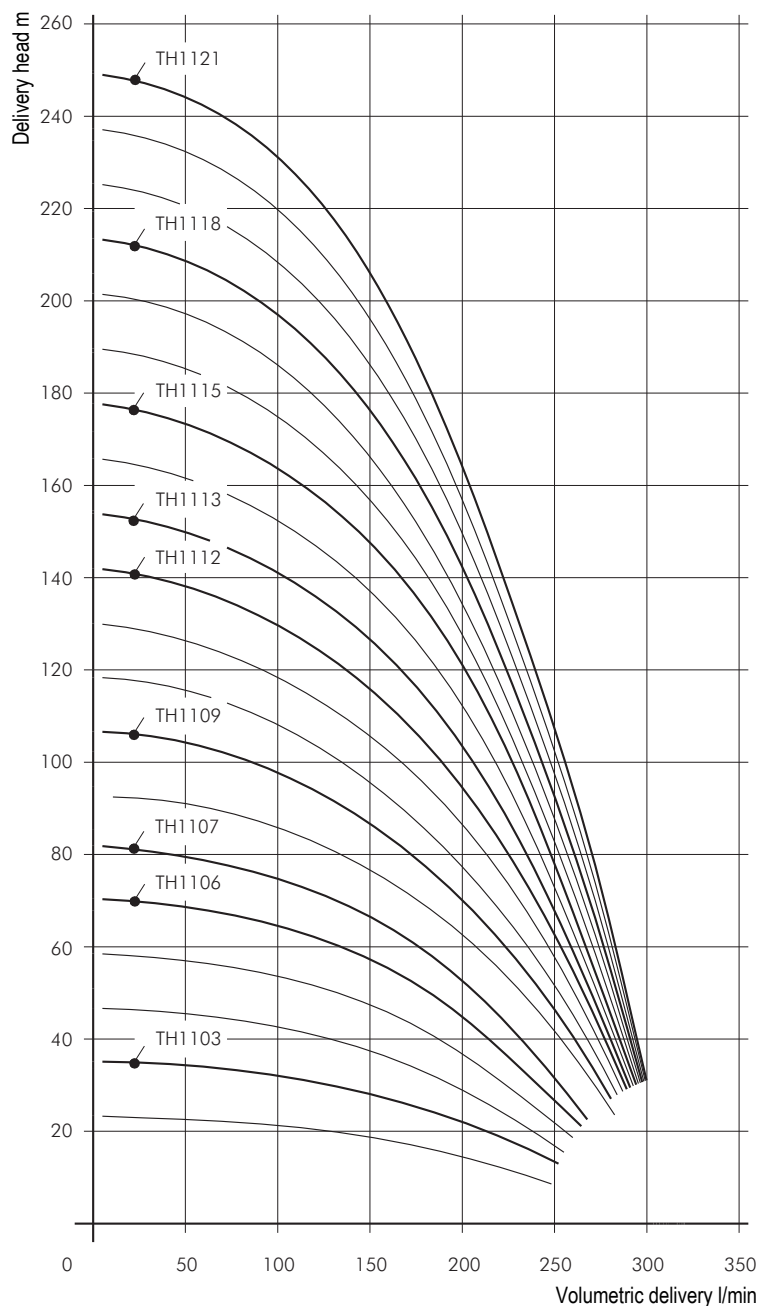

# Immersion Pumps

## (S)TH14

Closed impellers

50 Hz

### TH1402...1417

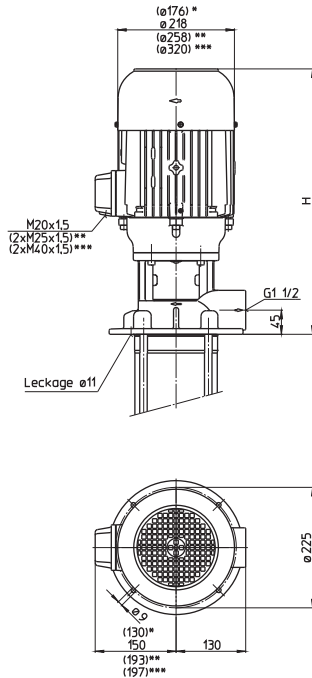

### STH1402...1417

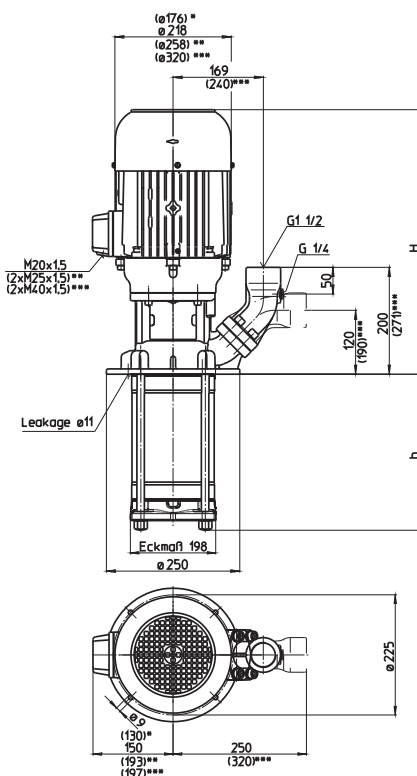

- \*) Dimension for (S)TH1402...1403
- \*\*) Dimension for (S)TH1406...1413
- \*\*\*) Dimension for (S)TH1414...1417

Type	Vol. del. at manom. del. head l/min / m	Height H mm	Depth of immersion h mm	Weight kg	Power kW	Voltage 3 ~ V	Fre- quency Hz	Rated current A	Speed 1/min
<b>(S)TH1402A180</b>	250/21	406	182	35	1.7	220-240 380-420	50 50	7.1 4.1	2850 2850
<b>(S)TH1403A280</b>	250/38	441	278	41	2.6	220-240 380-420	50 50	10.9 6.3	2850 2850
<b>(S)TH1404A280</b>	250/48	496	278	52	3.3	220-240 380-420	50 50	13.8 8.0	2900 2900
<b>(S)TH1405A380</b>	250/60	496	374	57	4.0	220-240 380-420	50 50	16.5 9.5	2900 2900
<b>(S)TH1406A380</b>	250/74	532	374	74	5.0	220-240 380-420	50 50	20.8 12.0	2900 2900
<b>(S)TH1407A470</b>	250/85	532	470	76	5.5	220-240 380-420	50 50	22.0 12.5	2900 2900
<b>(S)TH1408A470</b>	250/98	570	470	85	7.5	220-240 380-420	50 50	29 17	2900 2900
<b>(S)TH1409A570</b>	250/110		566	87					
<b>(S)TH1410A570</b>	250/120	620	566	102	10.0	220-240 380-420	50 50	40 23	2900 2900
<b>(S)TH1411A660</b>	250/134		662	105					
<b>(S)TH1412A660</b>	250/144			106					
<b>(S)TH1413A760</b>	250/159		758	108					
<b>(S)TH1414A760</b>	250/170	926	758	126	15.0	400	50	26.5	2945
<b>(S)TH1415A900</b>	250/180		902	129					
<b>(S)TH1416A900</b>	250/190			130					
<b>(S)TH1417A900</b>	250/200			131					

## Immersion Pumps

series TH and FH use **closed impellers** in order to minimize power consumption and to optimize hydraulic pump efficiencies. In addition, the TH series offers high pressures at short immersion depths. Inline pumps of the series FH can be used as **boosting pumps** if provided with positive inlet pressure. This inlet pressure can be provided by the central coolant supply or a feed pump. In such a setup, pumps of the series FH can raise the incoming pressure by up to 26 bar.

**Extended length is possible.** See mechanical/hydraulic features within the technical information section.

## Applications

Types of fluid  
 water  
 coolants  
 cooling/cutting oils  
 Kinematic viscosity  
 ...25 mm<sup>2</sup>/s (25 cSt)  
 Pumping temperature  
 0...80° C

## Construction

Pump body	cast iron
Cover	cast iron
Impellers	CrNi-steel
Shaft	CrNi-steel
Diffusers	CrNi-steel
Mechanical seal	SiC
O-rings	Viton

Optional:  
 Pole-changing motor 4 - 2 poles

Noise level  
 (S)TH1402...(S)TH1403 63 dBA  
 (S)TH1404...(S)TH1407 71 dBA  
 (S)TH1408...(S)TH1413 74 dBA  
 (S)TH1414...(S)TH1417 78 dBA

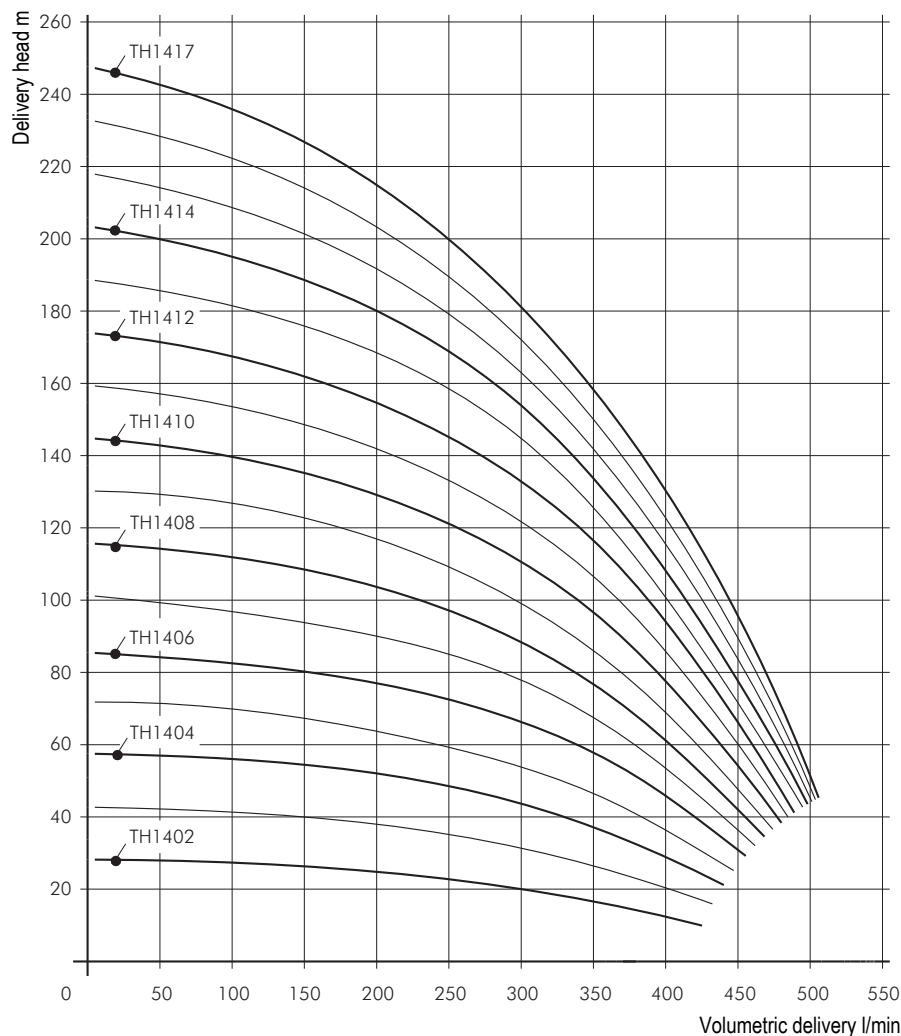

# Immersion Pumps

## (S)TH2

Closed impellers



### TH203...231

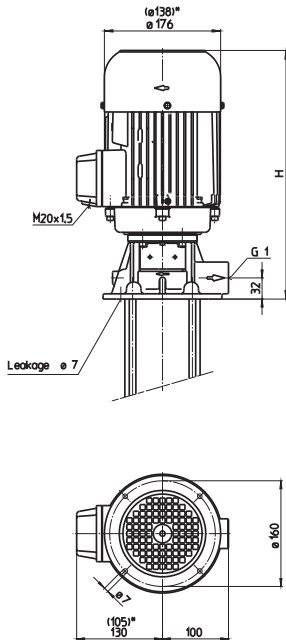

### STH203...231

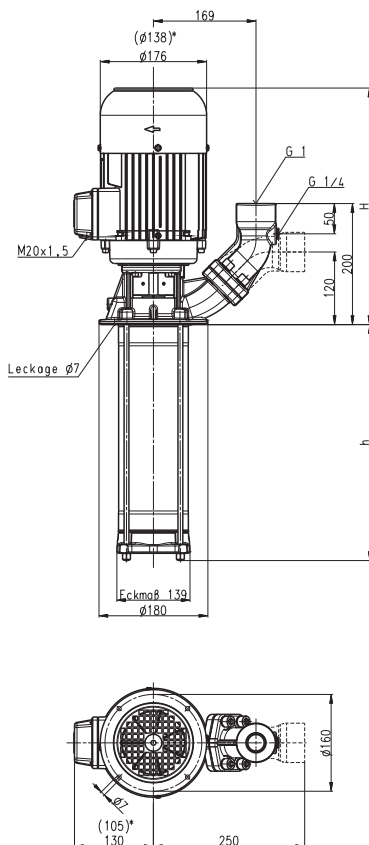

\*) Dimensions for (S)TH203...(S)TH215

Type	Vol. del. at manom. del. head l/min / m	Height H mm	Depth of immersion h mm	Weight kg	Power kW	Voltage 3 ~ V	Fre- quency Hz	Rated current A	Speed 1/min
(S)TH203B190	20/25	291	190	14.4	0.45	460	60	1.1	3200
(S)TH204B190	20/30			14.5					
(S)TH205B190	20/40	291	190	14.9	0.54	460	60	1.4	3300
(S)TH206B190	20/50			15.0					
(S)TH207B290	20/57	309	290	16.8	0.75	460	60	2.2	3300
(S)TH208B290	20/64			16.9					
(S)TH209B290	20/74			17.0					
(S)TH210B290	20/81			17.1					
(S)TH211B290	20/90	309	290	18.0	0.92	460	60	2.7	3300
(S)TH212B390	20/98		390	18.5					
(S)TH213B390	20/106			18.6					
(S)TH214B390	20/113	329	390	19.6	1.1	460	60	2.9	3300
(S)TH215B390	20/119			19.7					
(S)TH216B390	20/127	352	390	27	1.3	460	60	3	3400
(S)TH217B490	20/136	352	490	28.0	1.5	460	60	3.8	3400
(S)TH218B490	20/146			28.1					
(S)TH219B490	20/156			28.2					
(S)TH220B490	10/164	352	490	28.7	1.7	460	60	4.1	3400
(S)TH221B490	20/172			28.8					
(S)TH222B590	20/182	376	590	33.2	1.9	460	60	4.9	3400
(S)TH223B590	20/191			33.3					
(S)TH224B590	20/200	376	590	33.9	2.2	460	60	5.3	3400
(S)TH225B590	20/208			34.0					
(S)TH226B590	20/216			34.1					
(S)TH227B690	20/224		690	34.6					
(S)TH228B690	20/231	386	690	35.2	2.6	460	60	6.3	3400
(S)TH229B690	20/238			35.3					
(S)TH230B690	20/245			35.4					
(S)TH231B690	20/252			35.5					

**Immersion Pumps**

series TH and FH use **closed impellers** in order to minimize power consumption and to optimize hydraulic pump efficiencies. In addition, the TH series offers high pressures at short immersion depths. Inline pumps of the series FH can be used as **boosting pumps** if provided with positive inlet pressure. This inlet pressure can be provided by the central coolant supply or a feed pump. In such a setup, pumps of the series FH can raise the incoming pressure by up to 26 bar.

**Extended length is possible.** See mechanical/hydraulic features within the technical information section.

**Applications**

- Types of fluid
  - water
  - coolants
  - cooling/cutting oils
- Kinematic viscosity
  - ...25 mm<sup>2</sup>/s (25 cSt)
- Pumping temperature
  - 0...80° C

**Construction**

Pump body	cast iron
Cover	cast iron
Impellers	CrNi-steel
Shaft	CrNi-steel
Diffusers	CrNi-steel
Mechanical seal	SiC
O-rings	Viton
Optional:	
Pole-changing motor	4 - 2 poles
Pump body	bronze
Cover	bronze

Noise level	
(S)TH203...(S)TH215	61 dBA
(S)TH216...(S)TH231	66 dBA

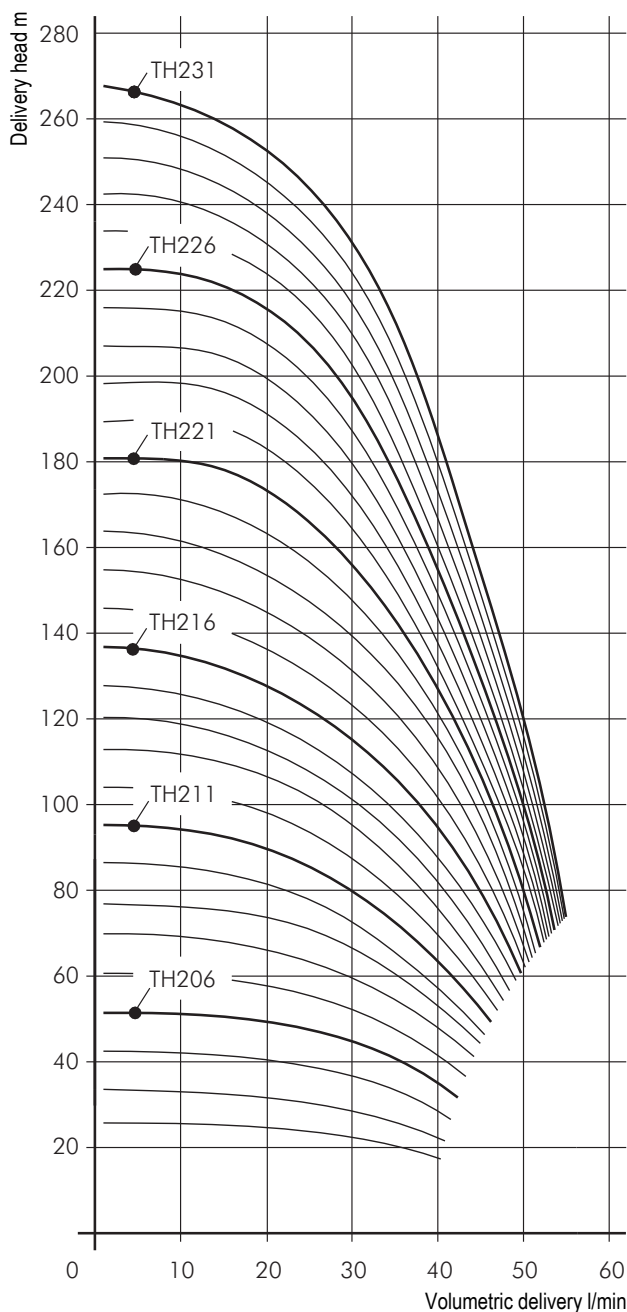

# Immersion Pumps

## (S)TH4

Closed impellers

60 Hz

### TH403...424

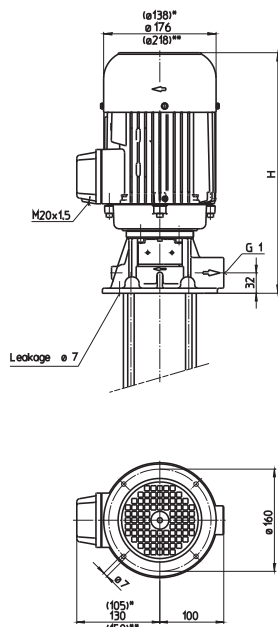

### STH403...424

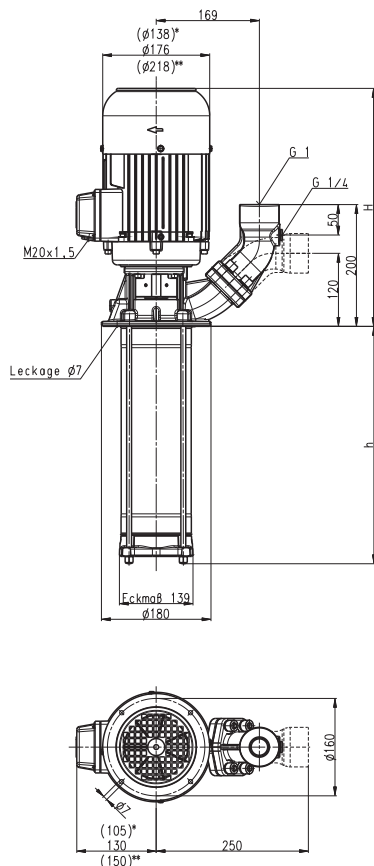

\*) Dimensions for (S)TH403...(S)TH408  
 \*\*) Dimensions for (S)TH419...(S)TH424

Type	Vol. del. at manom. del. head l/min / m	Height H mm	Depth of immersion h mm	Weight kg	Power kW	Voltage 3 ~ V	Fre- quency Hz	Rated current A	Speed 1/min
(S)TH403B190	40/29	291	190	14.7	0.54	460	60	1.4	3300
(S)TH404B190	40/39	309	190	17.1	0.75	460	60	2.2	3300
(S)TH405B190	40/49			17.2					
(S)TH406B190	40/58	309	190	18.2	0.92	460	60	2.7	3300
(S)TH407B290	40/68	329	290	19.6	1.1	460	60	2.9	3300
(S)TH408B290	40/78			19.7					
(S)TH409B290	40/88	352	290	27	1.3	460	60	3	3400
(S)TH410B290	40/100	352	290	27.6	1.5	460	60	3.8	3400
(S)TH411B290	40/110	352	290	28.1	1.7	460	60	4.1	3400
(S)TH412B390	40/119		390	28.6					
(S)TH413B390	40/129	376	390	32.6	1.9	460	60	4.9	3400
(S)TH414B390	40/139	376	390	33.2	2.2	460	60	5.3	3400
(S)TH415B390	40/150			33.3					
(S)TH416B390	40/159	386	390	33.9	2.6	460	60	6.3	3400
(S)TH417B490	40/170		490	34.4					
(S)TH418B490	40/179			34.5					
(S)TH419B490	40/192	441	490	44.7	3.3	460	60	8	3450
(S)TH420B490	40/202			44.8					
(S)TH421B490	40/214			44.9					
(S)TH422B590	40/224		590	45.4					
(S)TH423B590	40/233			45.5					
(S)TH424B590	40/242	441	590	48	4.0	460	60	9.5	3450



**Immersion Pumps**

series TH and FH use **closed impellers** in order to minimize power consumption and to optimize hydraulic pump efficiencies. In addition, the TH series offers high pressures at short immersion depths. Inline pumps of the series FH can be used as **boosting pumps** if provided with positive inlet pressure. This inlet pressure can be provided by the central coolant supply or a feed pump. In such a setup, pumps of the series FH can raise the incoming pressure by up to 26 bar.

**Extended length is possible.** See mechanical/hydraulic features within the technical information section.

**Applications**

- Types of fluid
  - water
  - coolants
  - cooling/cutting oils
- Kinematic viscosity
  - ...25 mm<sup>2</sup>/s (25 cSt)
- Pumping temperature
  - 0...80° C

**Construction**

Pump body	cast iron
Cover	cast iron
Impellers	CrNi-steel
Shaft	CrNi-steel
Diffusers	CrNi-steel
Mechanical seal	SiC
O-rings	Viton
Optional:	
Pole-changing motor	4 - 2 poles
Pump body	bronze
Cover	bronze
Noise level	
(S)TH403...(S)TH408	61 dBA
(S)TH409...(S)TH418	66 dBA
(S)TH419...(S)TH424	75 dBA

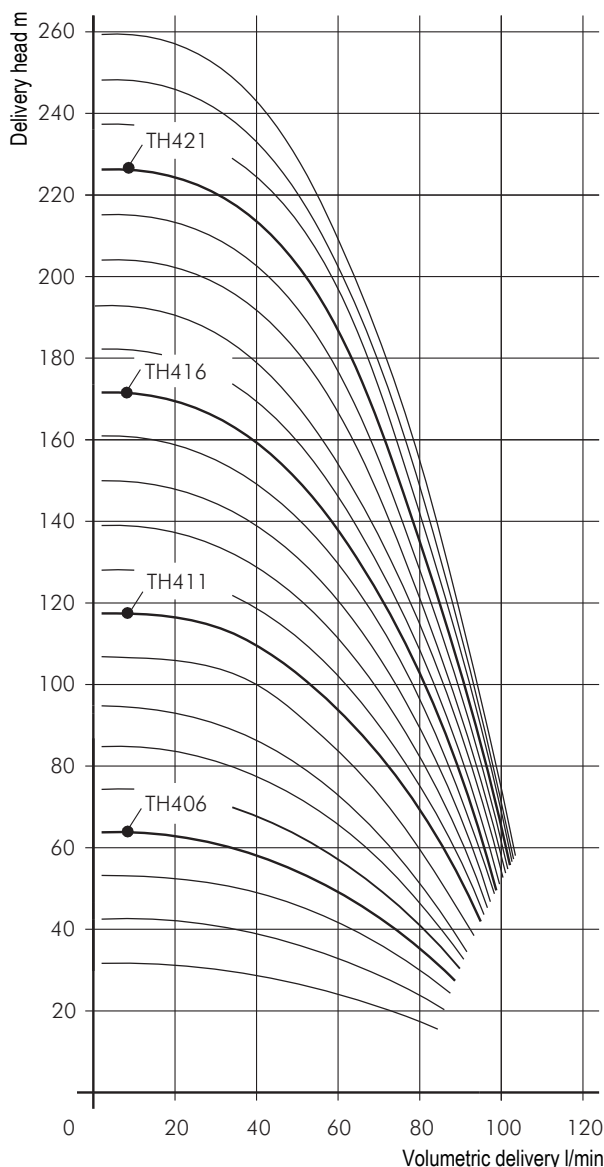

# Immersion Pumps

## (S)TH6

Closed impellers

60 Hz

### TH603...624

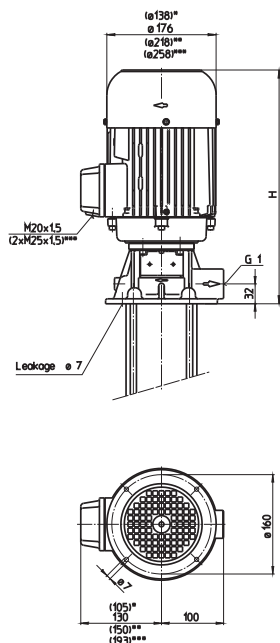

### STH603...624

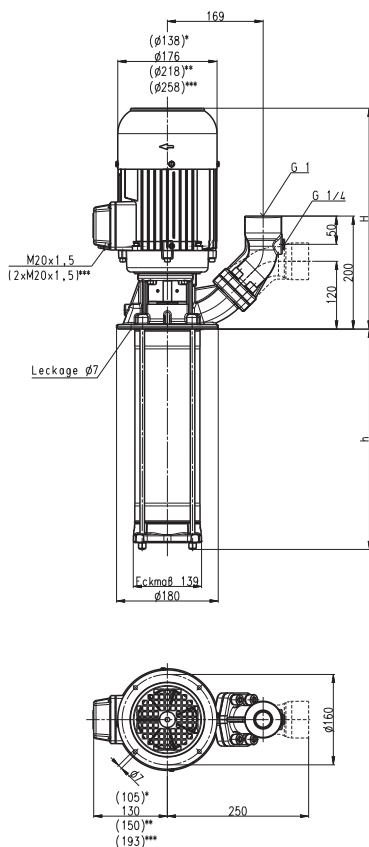

\*) Dimensions for (S)TH603...(S)TH605

\*\*) Dimensions for (S)TH613...(S)TH617

\*\*) Dimensions for (S)TH613...(S)TH617

\*\*) Dimensions for (S)TH613...(S)TH617

\*\*) Dimensions for (S)TH613...(S)TH617

\*\*) Dimensions for (S)TH613...(S)TH617

\*\*) Dimensions for (S)TH613...(S)TH617

\*\*) Dimensions for (S)TH613...(S)TH617

\*\*) Dimensions for (S)TH613...(S)TH617

\*\*) Dimensions for (S)TH613...(S)TH617

\*\*) Dimensions for (S)TH613...(S)TH617

\*\*) Dimensions for (S)TH613...(S)TH617

\*\*) Dimensions for (S)TH613...(S)TH617

\*\*) Dimensions for (S)TH613...(S)TH617

\*\*) Dimensions for (S)TH613...(S)TH617

\*\*) Dimensions for (S)TH613...(S)TH617

\*\*) Dimensions for (S)TH613...(S)TH617

\*\*) Dimensions for (S)TH613...(S)TH617

\*\*) Dimensions for (S)TH613...(S)TH617

\*\*) Dimensions for (S)TH613...(S)TH617

\*\*) Dimensions for (S)TH613...(S)TH617

\*\*) Dimensions for (S)TH613...(S)TH617

\*\*) Dimensions for (S)TH613...(S)TH617

\*\*) Dimensions for (S)TH613...(S)TH617

\*\*) Dimensions for (S)TH613...(S)TH617

\*\*) Dimensions for (S)TH613...(S)TH617

\*\*) Dimensions for (S)TH613...(S)TH617

\*\*) Dimensions for (S)TH613...(S)TH617

\*\*) Dimensions for (S)TH613...(S)TH617

\*\*) Dimensions for (S)TH613...(S)TH617

\*\*) Dimensions for (S)TH613...(S)TH617

\*\*) Dimensions for (S)TH613...(S)TH617

\*\*) Dimensions for (S)TH613...(S)TH617

\*\*) Dimensions for (S)TH613...(S)TH617

\*\*) Dimensions for (S)TH613...(S)TH617

\*\*) Dimensions for (S)TH613...(S)TH617

\*\*) Dimensions for (S)TH613...(S)TH617

\*\*) Dimensions for (S)TH613...(S)TH617

\*\*) Dimensions for (S)TH613...(S)TH617

\*\*) Dimensions for (S)TH613...(S)TH617

\*\*) Dimensions for (S)TH613...(S)TH617

\*\*) Dimensions for (S)TH613...(S)TH617

\*\*) Dimensions for (S)TH613...(S)TH617

\*\*) Dimensions for (S)TH613...(S)TH617

\*\*) Dimensions for (S)TH613...(S)TH617

\*\*) Dimensions for (S)TH613...(S)TH617

\*\*) Dimensions for (S)TH613...(S)TH617

\*\*) Dimensions for (S)TH613...(S)TH617

\*\*) Dimensions for (S)TH613...(S)TH617

\*\*) Dimensions for (S)TH613...(S)TH617

\*\*) Dimensions for (S)TH613...(S)TH617

\*\*) Dimensions for (S)TH613...(S)TH617

\*\*) Dimensions for (S)TH613...(S)TH617

\*\*) Dimensions for (S)TH613...(S)TH617

\*\*) Dimensions for (S)TH613...(S)TH617

\*\*) Dimensions for (S)TH613...(S)TH617

\*\*) Dimensions for (S)TH613...(S)TH617

\*\*) Dimensions for (S)TH613...(S)TH617

\*\*) Dimensions for (S)TH613...(S)TH617

\*\*) Dimensions for (S)TH613...(S)TH617

\*\*) Dimensions for (S)TH613...(S)TH617

\*\*) Dimensions for (S)TH613...(S)TH617

\*\*) Dimensions for (S)TH613...(S)TH617

\*\*) Dimensions for (S)TH613...(S)TH617

\*\*) Dimensions for (S)TH613...(S)TH617

Type	Vol. del. at manom. del. head l/min / m	Height H mm	Depth of im- mersion h mm	Weight kg	Power kW	Voltage 3 ~ V	Fre- quency Hz	Rated current A	Speed 1/min
(S)TH603B190	80/28	291	190	16.4	0.75	460	60	2.2	3300
(S)TH604B190	80/38	309	190	17.5	0.92	460	60	2.7	3300
(S)TH605B240	80/48	329	240	18.3	1.1	460	60	2.9	3300
(S)TH606B240	80/58	352	240	25.4	1.5	460	60	3.8	3400
(S)TH607B290	80/68	352	290	29.7	1.7	460	60	4.1	3400
(S)TH608B290	80/78	376	290	33.8	1.9	460	60	4.9	3400
(S)TH609B340	80/88	376	340	34.5	2.2	460	60	5.3	3400
(S)TH610B340	80/98	386	340	35.1	2.6	460	60	6.3	3400
(S)TH611B390	80/108		390	35.6					
(S)TH612B390	80/118			35.7					
(S)TH613B490	80/128	441	490	49.6	3.3	460	60	8	3450
(S)TH614B490	80/139			49.7					
(S)TH615B490	80/149			49.8					
(S)TH616B490	80/159	441	490	52.3	4.0	460	60	9.5	3450
(S)TH617B590	80/168		590	52.8					
(S)TH618B590	80/178	477	590	69.4	5.0	460	60	12	3450
(S)TH619B590	80/188			69.5					
(S)TH620B590	80/198			69.6					
(S)TH621B690	80/206		690	70.1					
(S)TH622B690	80/214			70.2					
(S)TH623B690	80/222	477	690	71.2	5.5	460	60	12.5	3450
(S)TH624B690	80/232			71.3					

### Immersion Pumps

series TH and FH use **closed impellers** in order to minimize power consumption and to optimize hydraulic pump efficiencies. In addition, the TH series offers high pressures at short immersion depths. Inline pumps of the series FH can be used as **boosting pumps** if provided with positive inlet pressure. This inlet pressure can be provided by the central coolant supply or a feed pump. In such a setup, pumps of the series FH can raise the incoming pressure by up to 26 bar.

**Extended length is possible.** See mechanical/hydraulic features within the technical information section.

### Applications

Types of fluid  
 water  
 coolants  
 cooling/cutting oils  
 Kinematic viscosity  
 ...25 mm<sup>2</sup>/s (25 cSt)  
 Pumping temperature  
 0...80° C

### Construction

Pump body	cast iron
Cover	cast iron
Impellers	CrNi-steel
Shaft	CrNi-steel
Diffusers	CrNi-steel
Mechanical seal	SiC
O-rings	Viton
Optional:	
Pole-changing motor	4 - 2 poles
Pump body	bronze
Cover	bronze

Noise level	
(S)TH603...(S)TH605	61 dBA
(S)TH606...(S)TH612	66 dBA
(S)TH613...(S)TH624	75 dBA

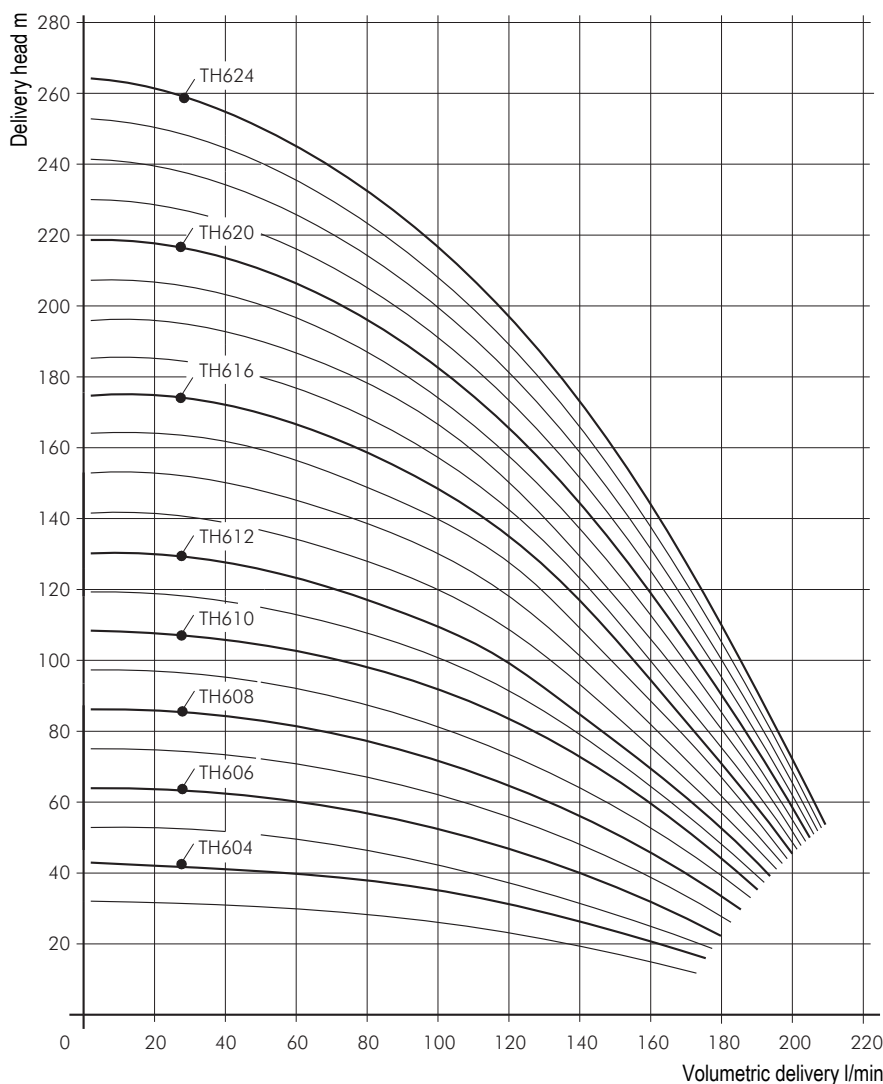

# Immersion Pumps

## (S)TH11

Closed impellers

60 Hz

### TH1102...1115

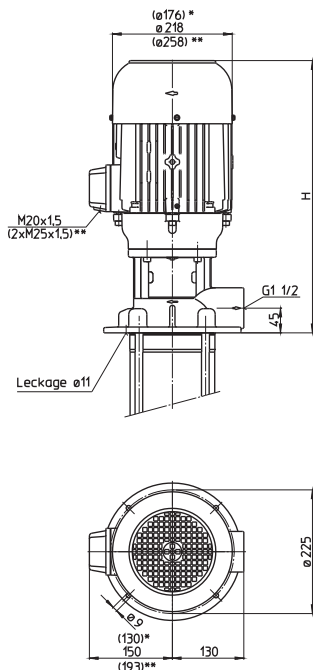

### STH1102...1115

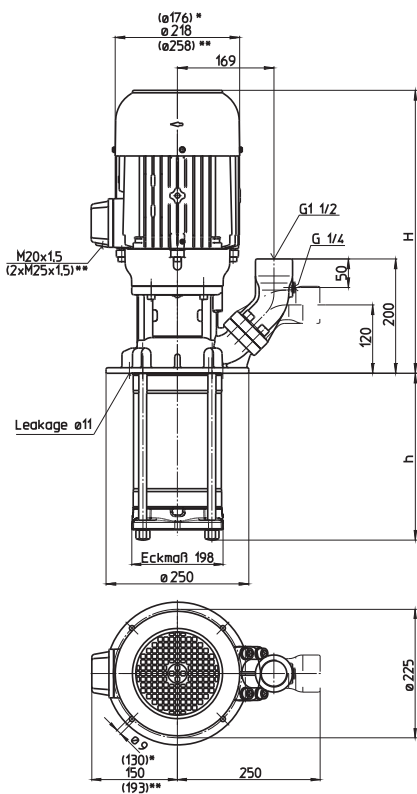

\*) Dimensions for (S)TH1102...1104  
 \*\*) Dimensions for (S)TH1107...1115

Type	Vol. del. at manom. del. head l/min / m	Height H mm	Depth of im- mersion h mm	Weight kg	Power kW	Voltage 3~ V	Fre- quency Hz	Rated current A	Speed 1/min
<b>(S)TH1102B180</b>	150/30	406	182	34	1.3	460	60	3	3400
<b>(S)TH1103B180</b>	150/45	431	182	38	1.5	460	60	3.8	3400
<b>(S)TH1104B280</b>	150/59	441	278	41	2.6	460	60	6.3	3400
<b>(S)TH1105B280</b>	150/77	496	278	52	3.3	460	60	8	3450
<b>(S)TH1106B280</b>	150/90	496	278	55	4.0	460	60	9.5	3450
<b>(S)TH1107B310</b>	150/106	532	310	72	5.0	460	60	12	3450
<b>(S)TH1108B380</b>	150/121		374	74					
<b>(S)TH1109B380</b>	150/138	532	374	75	5.5	460	60	12.5	3450
<b>(S)TH1110B470</b>	150/152	570	470	84	7.5	460	60	17	3450
<b>(S)TH1111B470</b>	150/166			85					
<b>(S)TH1112B470</b>	150/180			86					
<b>(S)TH1113B500</b>	150/198		502	87					
<b>(S)TH1114B570</b>	150/212	620	566	103	10.0	460	60	23	3450
<b>(S)TH1115B570</b>	150/230			104					

**Immersion Pumps**

Series TH and FH use **closed impellers** in order to minimize power consumption and to optimize hydraulic pump efficiencies.

In addition, the TH series offers high pressures at short immersion depths.

Inline pumps of the series FH can be used as **boosting pumps** if provided with positive inlet pressure. This inlet pressure can be provided by the central coolant supply or a feed pump. In such a setup, pumps of the series FH can raise the incoming pressure by up to 26 bar.

**Extended length is possible.** See mechanical/hydraulic features within the technical information section.

**Applications**

- Types of fluid
  - water
  - coolants
  - cooling/cutting oils
- Kinematic viscosity  
...25 mm<sup>2</sup>/s (25 cSt)
- Pumping temperature  
0...80° C

**Construction**

Pump body	cast iron
Cover	cast iron
Impellers	CrNi-steel
Shaft	CrNi-steel
Diffusers	CrNi-steel
Mechanical seal	SiC
O-rings	Viton
Optional: Pole-changing motor	4 - 2 poles
Noise level	
(S)TH1102...(S)TH1104	66 dBA
(S)TH1105...(S)TH1109	74 dBA
(S)TH1110...(S)TH1115	77 dBA

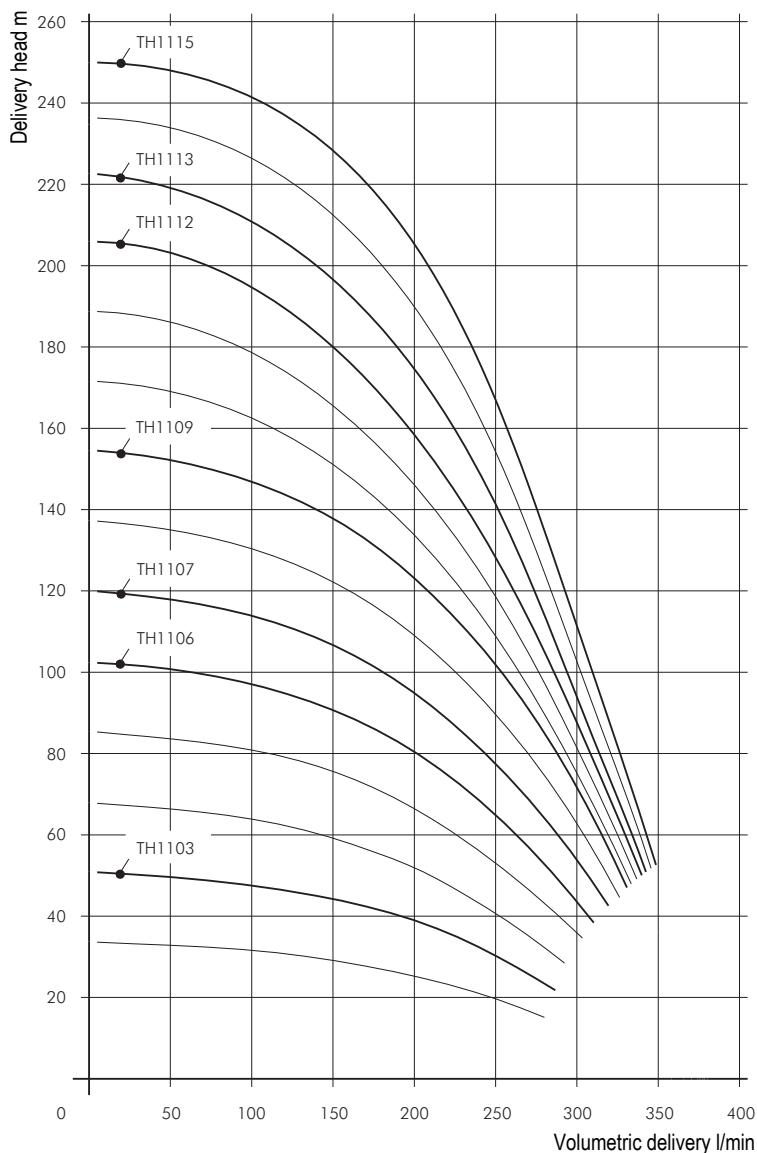

# Immersion Pumps

## (S)TH14

Closed impellers

60 Hz

### TH1402...1412

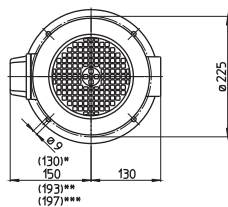
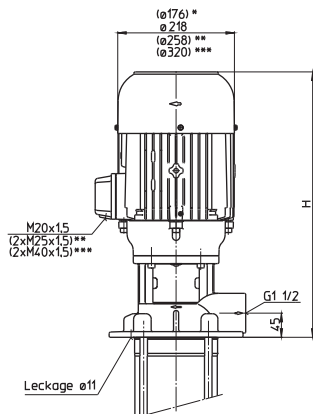

### STH1402...1412

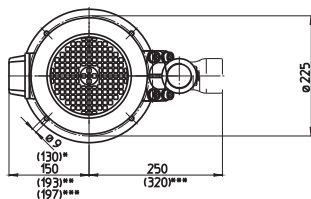
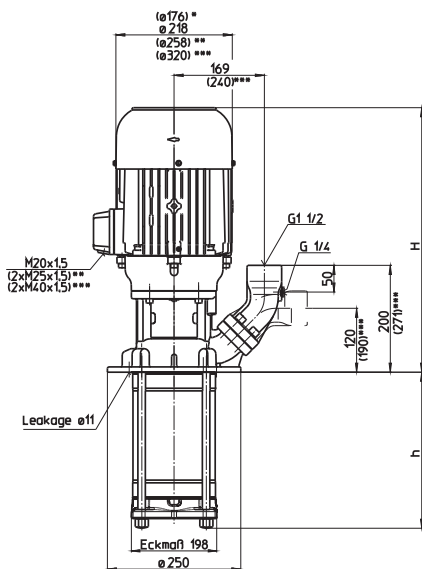

\*) Dimensions for (S)TH1402

\*\*) Dimensions for (S)TH1404...1408

\*\*\*) Dimensions for (S)TH1409...1412

Type	Vol. del. at manom. del. head l/min / m	Height H mm	Depth of im- mersion h mm	Weight kg	Power kW	Voltage 3 ~ V	Fre- quency Hz	Rated current A	Speed 1/min
<b>(S)TH1402B180</b>	250/38	441	182	39	2.6	460	60	6.3	3400
<b>(S)TH1403B280</b>	250/58	496	278	54	4.0	460	60	9.5	3450
<b>(S)TH1404B280</b>	250/77	532	278	72	5.5	460	60	12.5	3450
<b>(S)TH1405B380</b>	250/96	570	374	81	7.5	460	60	17	3450
<b>(S)TH1406B380</b>	250/111			82					
<b>(S)TH1407B470</b>	250/128	620	470	99	10.0	460	60	23	3450
<b>(S)TH1408B470</b>	250/147			100					
<b>(S)TH1409B570</b>	250/165	926	566	120	17.3	460	60	26	3545
<b>(S)TH1410B570</b>	250/184			121					
<b>(S)TH1411B660</b>	250/203		662	123					
<b>(S)TH1412B660</b>	250/222			124					

### Immersion Pumps

series TH and FH use **closed impellers** in order to minimize power consumption and to optimize hydraulic pump efficiencies. In addition, the TH series offers high pressures at short immersion depths. Inline pumps of the series FH can be used as **boosting pumps** if provided with positive inlet pressure. This inlet pressure can be provided by the central coolant supply or a feed pump. In such a setup, pumps of the series FH can raise the incoming pressure by up to 26 bar.

**Extended length is possible.** See mechanical/hydraulic features within the technical information section.

### Applications

Types of fluid  
 water  
 coolants  
 cooling/cutting oils  
 Kinematic viscosity  
 ...25 mm<sup>2</sup>/s (25 cSt)  
 Pumping temperature  
 0...80° C

### Construction

Pump body	cast iron
Cover	cast iron
Impellers	CrNi-steel
Shaft	CrNi-steel
Diffusers	CrNi-steel
Mechanical seal	SiC
O-rings	Viton
Optional: Pole-changing motor	4 - 2 poles
Noise level	
(S)TH1402	66 dBA
(S)TH1403...(S)TH1404	74 dBA
(S)TH1405...(S)TH1408	77 dBA
(S)TH1409...(S)TH1412	81 dBA

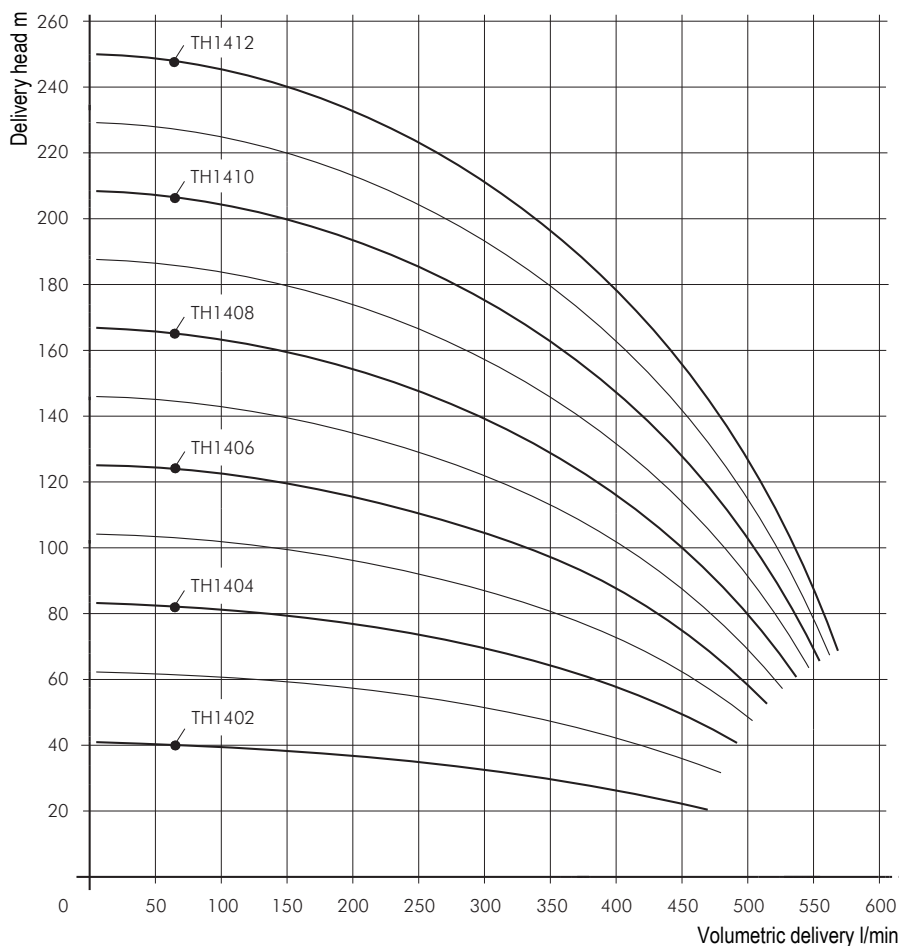

# Pressure Boosting Pumps

## FH2

Closed impellers

50 Hz

### FH203...240

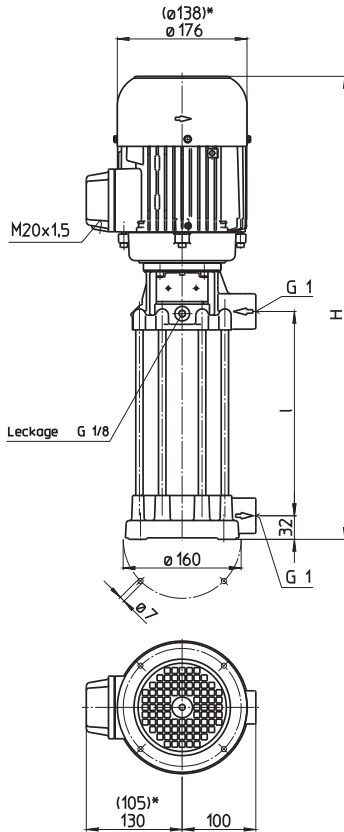

\*) Dimensions for FH203...FH223

Type	Vol. del. at manom. del. head l/min / m	Height H mm	Length l mm	Weight kg	Power kW	Voltage 3~ V	Fre- quency Hz	Rated current A	Speed 1/min
<b>FH203A19</b>	20/15	488	197	16.9	0.45	220-240 380-420	50	1.9	2800
<b>FH204A19</b>	20/20			17.0					
<b>FH205A19</b>	20/25			17.1					
<b>FH206A29</b>	20/30	588	297	17.6	0.54	220-240 380-420	50	2.42	2800
<b>FH207A29</b>	20/35			17.7					
<b>FH208A29</b>	20/40	588	297	18.1					
<b>FH209A29</b>	20/45			18.2	0.75	220-240 380-420	50	3.8	2700
<b>FH210A29</b>	20/50			18.3					
<b>FH211A39</b>	20/56	688	397	18.8					
<b>FH212A39</b>	20/60	706	397	20.6	0.92	220-240 380-420	50	4.7	2700
<b>FH213A39</b>	20/68			20.7					
<b>FH214A39</b>	20/75			20.8					
<b>FH215A39</b>	20/82	706	397	21.7	1.1	220-240 380-420	50	5.0	2700
<b>FH216A49</b>	20/88	806	497	22.2					
<b>FH217A49</b>	20/93			22.3					
<b>FH218A49</b>	20/98			22.4	1.3	220-240 380-420	50	5.2	2850
<b>FH219A49</b>	20/102	826	497	23.4					
<b>FH220A49</b>	20/108			23.5					
<b>FH221A59</b>	20/112	926	597	24.0	1.5	220-240 380-420	50	6.6	2850
<b>FH222A59</b>	20/118			24.1					
<b>FH223A59</b>	20/125			24.2					
<b>FH224A59</b>	20/130	949	597	31.5	1.7	220-240 380-420	50	7.1	2850
<b>FH225A59</b>	20/135			31.6					
<b>FH226A69</b>	20/142	1049	697	32.6					
<b>FH227A69</b>	20/150			32.7	1.9	220-240 380-420	50	8.5	2850
<b>FH228A69</b>	20/155			32.8					
<b>FH229A69</b>	20/160	1049	697	33.3					
<b>FH230A69</b>	20/166			33.4	2.2	220-240 380-420	50	9.2	2850
<b>FH231A79</b>	20/172	1149	797	33.9					
<b>FH232A79</b>	20/178			34.0					
<b>FH233A79</b>	20/182			34.1	0.92	220-240 380-420	50	4.7	2700
<b>FH234A79</b>	20/190	1173	797	38.1					
<b>FH235A79</b>	20/195			38.2					
<b>FH236A89</b>	20/200	1273	897	38.7	2.2	220-240 380-420	50	5.3	2850
<b>FH237A89</b>	20/205	1273	897	39.3					
<b>FH238A89</b>	20/210			39.4					
<b>FH239A89</b>	20/215			39.5	0.45	220-240 380-420	50	1.9	2800
<b>FH240A89</b>	20/220			39.6					



**Pressure Boosting Pumps**

series TH and FH use **closed impellers** in order to minimize power consumption and to optimize hydraulic pump efficiencies. In addition, the TH series offers high pressures at short immersion depths. Inline pumps of the series FH can be used as **boosting pumps** if provided with positive inlet pressure. This inlet pressure can be provided by the central coolant supply or a feed pump. In such a setup, pumps of the series FH can raise the incoming pressure by up to 26 bar. For alternating machining using **internally and externally cooled tools**, these models are available with YYY-configured **pole-changing motor** (Dahlander) for optional changeover to **half speed** operation. **A frequency converter** can be supplied for **special applications** or for matching the pump characteristic to a specific duty point. See page "Control/Regulation" in the Technical Information section of this catalog for further information.



**Applications**

Types of fluid  
 water  
 coolants  
 cooling/cutting oils  
 Kinematic viscosity  
 ...25 mm<sup>2</sup>/s (25 cSt)  
 Pumping temperature  
 0...80° C

**Construction**

Pump body	cast iron
Cover	cast iron
Impellers	CrNi-steel
Shaft	CrNi-steel
Diffusers	CrNi-steel
Mechanical seal	SiC
O-rings	Viton
Optional:	
Pole-changing motor	4 - 2 poles
Pump body	bronze
Cover	bronze
Noise level	
FH203...FH223	58 dBA
FH224...FH240	63 dBA

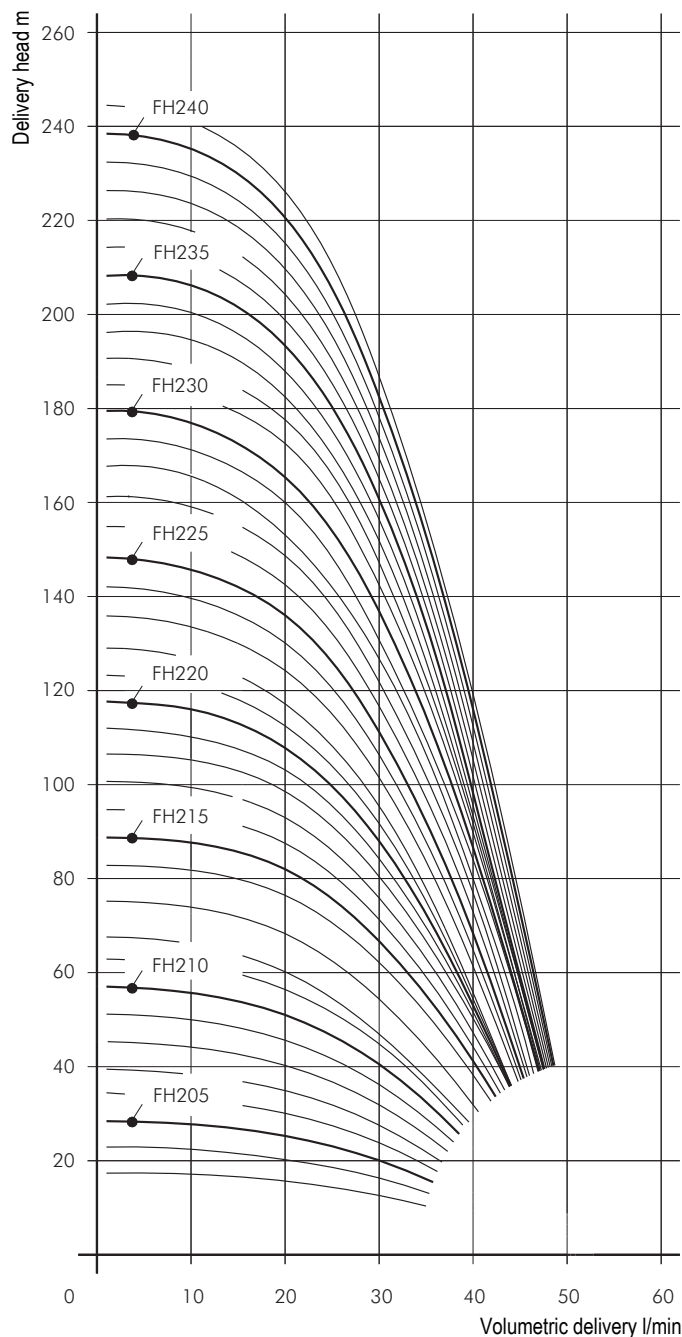

# Pressure Boosting Pumps



## FH4

Closed impellers

50 Hz

### FH403...435

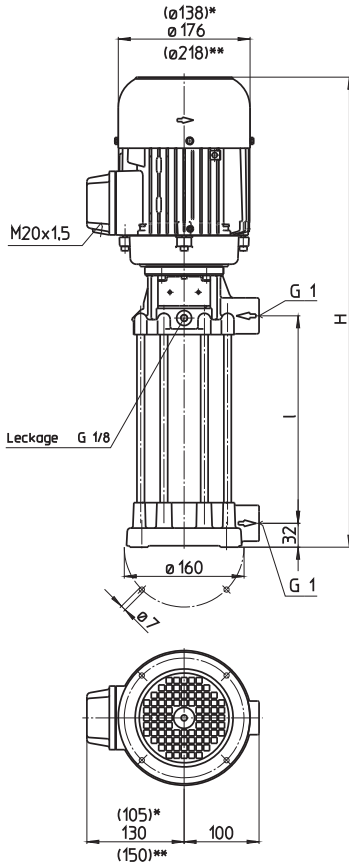

\*) Dimensions for FH403...FH413

\*\*) Dimensions for FH432...FH435

Type	Vol. del. at manom. del. head l/min / m	Height H mm	Length l mm	Weight kg	Power kW	Voltage 3~ V	Fre- quency Hz	Rated current A	Speed 1/min
<b>FH403A19</b>	40/18	488	197	16.9	0.45	220-240 380-420	50	1.9	2800
<b>FH404A19</b>	40/25			17.0					
<b>FH405A19</b>	40/30	488	197	17.4	0.54	220-240 380-420	50	2.42	2800
<b>FH406A29</b>	40/36	588	297	17.5					
<b>FH407A29</b>	40/42	606	297	20.3	0.75	220-240 380-420	50	3.8	2700
<b>FH408A29</b>	40/50			20.4					
<b>FH409A29</b>	40/56			20.5					
<b>FH410A29</b>	40/62	606	297	21.5	0.92	220-240 380-420	50	4.7	2700
<b>FH411A39</b>	40/68	706	397	22.0					
<b>FH412A39</b>	40/74	726	397	23.0	1.1	220-240 380-420	50	5.0	2700
<b>FH413A39</b>	40/80			23.1					
<b>FH414A39</b>	40/86	749	397	30.4	1.3	220-240 380-420	50	5.2	2850
<b>FH415A39</b>	40/95	749	397	31.0					
<b>FH416A49</b>	40/104	849	497	31.1	1.5	220-240 380-420	50	6.6	2850
<b>FH417A49</b>	40/112	849	497	31.6					
<b>FH418A49</b>	40/118			31.7	1.7	220-240 380-420	50	7.1	2850
<b>FH419A49</b>	40/125	873	497	35.8					
<b>FH420A49</b>	40/130			35.9	1.9	220-240 380-420	50	8.5	2850
<b>FH421A59</b>	40/136	973	597	36.9					
<b>FH422A59</b>	40/142			37.0	2.2	220-240 380-420	50	9.2	2850
<b>FH423A59</b>	40/150			37.1					
<b>FH424A59</b>	40/156			37.2					
<b>FH425A59</b>	40/162	983	597	37.8	2.6	220-240 380-420	50	10.9	2850
<b>FH426A69</b>	40/168	1083	697	38.4					
<b>FH427A69</b>	40/175			38.5	3.3	220-240 380-420	50	13.8	2900
<b>FH428A69</b>	40/182			38.6					
<b>FH429A69</b>	40/190			38.7					
<b>FH430A69</b>	40/198			38.8					
<b>FH431A79</b>	40/208	1183	797	39.3					
<b>FH432A79</b>	40/216	1238	797	49.5					
<b>FH433A79</b>	40/220			49.6					
<b>FH434A79</b>	40/230			49.7					
<b>FH435A79</b>	40/240			49.8					

## Pressure Boosting Pumps

series TH and FH use **closed impellers** in order to minimize power consumption and to optimize hydraulic pump efficiencies.

In addition, the TH series offers high pressures at short immersion depths.

Inline pumps of the series FH can be used as **boosting pumps** if provided with positive inlet pressure. This inlet pressure can be provided by the central coolant supply or a feed pump. In such a setup, pumps of the series FH can raise the incoming pressure by up to 26 bar.

For alternating machining using **internally** and **externally cooled tools**, these models are available with YYY-configured **pole-changing motor** (Dahlander) for optional changeover to **half speed** operation.

A **frequency converter** can be supplied for **special applications** or for matching the pump characteristic to a specific duty point.

See page "Control/Regulation" in the Technical Information section of this catalog for further information.



## Applications

Types of fluid  
 water  
 coolants  
 cooling/cutting oils  
 Kinematic viscosity  
 ...25 mm<sup>2</sup>/s (25 cSt)  
 Pumping temperature  
 0...80° C

## Construction

Pump body	cast iron
Cover	cast iron
Impellers	CrNi-steel
Shaft	CrNi-steel
Diffusers	CrNi-steel
Mechanical seal	SiC
O-rings	Viton

Optional:	
Pole-changing motor	4 - 2 poles
Pump body	bronze
Cover	bronze

Noise level	
FH403...FH413	58 dBA
FH414...FH431	63 dBA
FH432...FH435	71 dBA

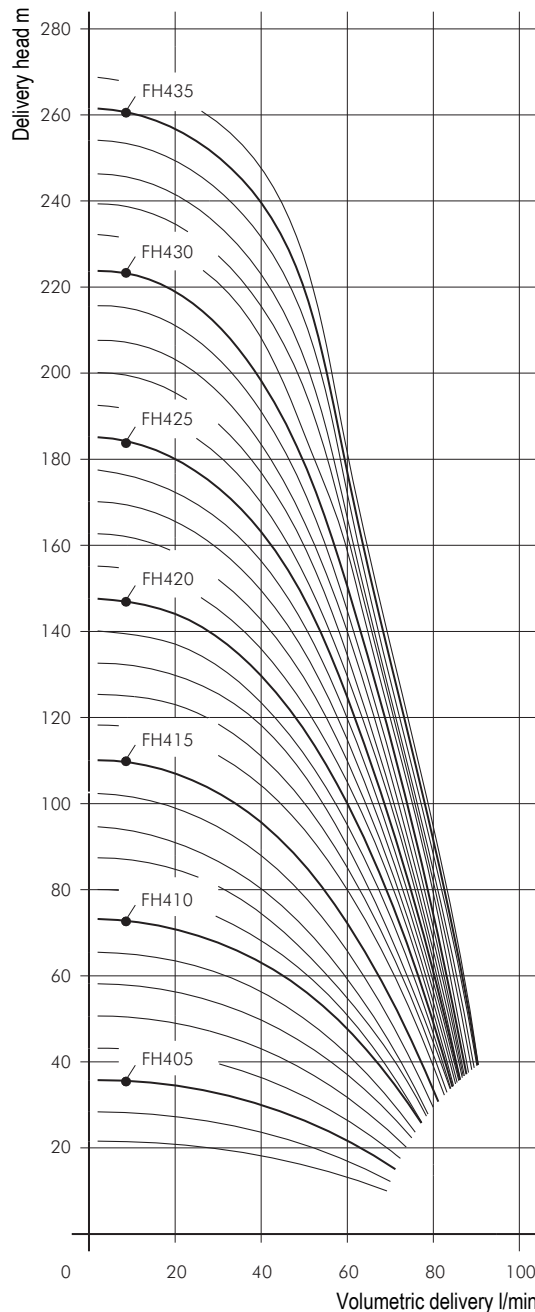

# Pressure Boosting Pumps



## FH6

Closed impellers

50 Hz

### FH603...632

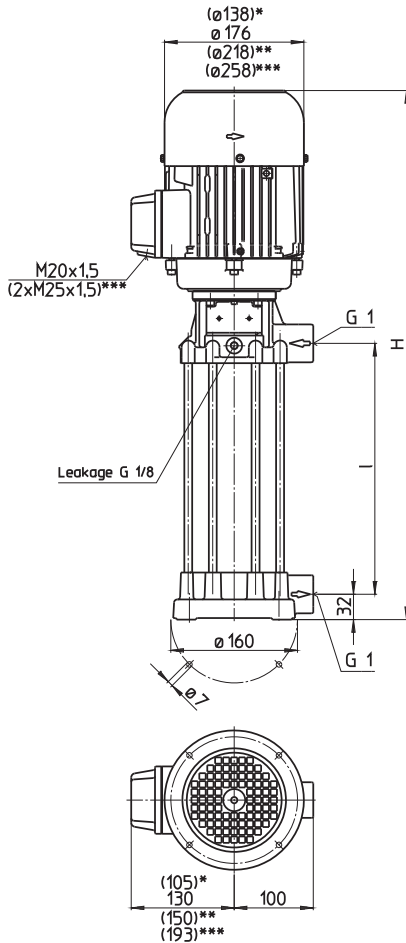

\*) Dimensions for FH603...FH608

\*\*) Dimensions for FH619...FH626

\*\*\*) Dimensions for FH627...FH632

Type	Vol. del. at manom. del. head l/min / m	Height H mm	Length l mm	Weight kg	Power kW	Voltage 3~ V	Fre- quency Hz	Rated current A	Speed 1/min
<b>FH603A19</b>	80/18	488	197	17.1	0.54	220-240 380-420	50	2.42 1.40	2800 2800
<b>FH604A19</b>	80/24	506	197	19.0	0.75	220-240 380-420	50	3.8 2.2	2700 2700
<b>FH605A24</b>	80/30	556	247	19.3					
<b>FH606A24</b>	80/36	556	247	20.2	0.92	220-240 380-420	50	4.7 2.7	2700 2700
<b>FH607A29</b>	80/41	606	297	20.5					
<b>FH608A29</b>	80/48	626	297	21.5	1.1	220-240 380-420	50	5.0 2.9	2700 2700
<b>FH609A34</b>	80/56	699	347	29.0	1.5	220-240 380-420	50	6.6 3.8	2850 2850
<b>FH610A34</b>	80/61			29.1					
<b>FH611A39</b>	80/71	749	397	33.4	1.7	220-240 380-420	50	7.1 4.1	2850 2850
<b>FH612A39</b>	80/76	773	397	37.5	1.9	220-240 380-420	50	8.5 4.9	2850 2850
<b>FH613A49</b>	80/82	873	497	38.0	2.2	220-240 380-420	50	9.2 5.3	2850 2850
<b>FH614A49</b>	80/90			38.1					
<b>FH615A49</b>	80/96			38.2					
<b>FH616A49</b>	80/101	883	497	38.8	2.6	220-240 380-420	50	10.9 6.3	2850 2850
<b>FH617A59</b>	80/108	983	597	39.3					
<b>FH618A59</b>	80/114			42.5					
<b>FH619A59</b>	80/120	1038	597	53.1	3.3	220-240 380-420	50	13.8 8.0	2900 2900
<b>FH620A59</b>	80/128			53.2					
<b>FH621A69</b>	80/136	1138	697	53.7					
<b>FH622A69</b>	80/142			53.8					
<b>FH623A69</b>	80/150	1138	697	56.3	4.0	220-240 380-420	50	16.5 9.5	2900 2900
<b>FH624A69</b>	80/155			56.4					
<b>FH625A79</b>	80/160	1238	797	57.0					
<b>FH626A79</b>	80/166			57.1					
<b>FH627A79</b>	80/172	1274	797	73.7	5.0	220-240 380-420	50	20.8 12.0	2900 2900
<b>FH628A79</b>	80/180			73.8					
<b>FH629A89</b>	80/186	1374	897	74.3					
<b>FH630A89</b>	80/192			74.4					
<b>FH631A89</b>	80/200			74.5					
<b>FH632A89</b>	80/206			74.6					

## Pressure Boosting Pumps

Series TH and FH use **closed impellers** in order to minimize power consumption and to optimize hydraulic pump efficiencies.

In addition, the TH series offers high pressures at short immersion depths.

Inline pumps of the series FH can be used as **boosting pumps** if provided with positive inlet pressure. This inlet pressure can be provided by the central coolant supply or a feed pump. In such a setup, pumps of the series FH can raise the incoming pressure by up to 26 bar.

For alternating machining using **internally** and **externally cooled tools**, these models are available with YYY-configured **pole-changing motor** (Dahlander) for optional changeover to **half speed** operation.

A **frequency converter** can be supplied for **special applications** or for matching the pump characteristic to a specific duty point.

See page "Control/Regulation" in the Technical Information section of this catalog for further information.

## Applications

Types of fluid  
 water  
 coolants  
 cooling/cutting oils  
 Kinematic viscosity  
 ...25 mm<sup>2</sup>/s (25 cSt)  
 Pumping temperature  
 0...80° C

## Construction

Pump body	cast iron
Cover	cast iron
Impellers	CrNi-steel
Shaft	CrNi-steel
Diffusers	CrNi-steel
Mechanical seal	SiC
O-rings	Viton

Optional:	
Pole-changing motor	4 - 2 poles
Pump body	bronze
Cover	bronze

Noise level	
FH603...FH608	58 dBA
FH609...FH618	63 dBA
FH619...FH632	71 dBA

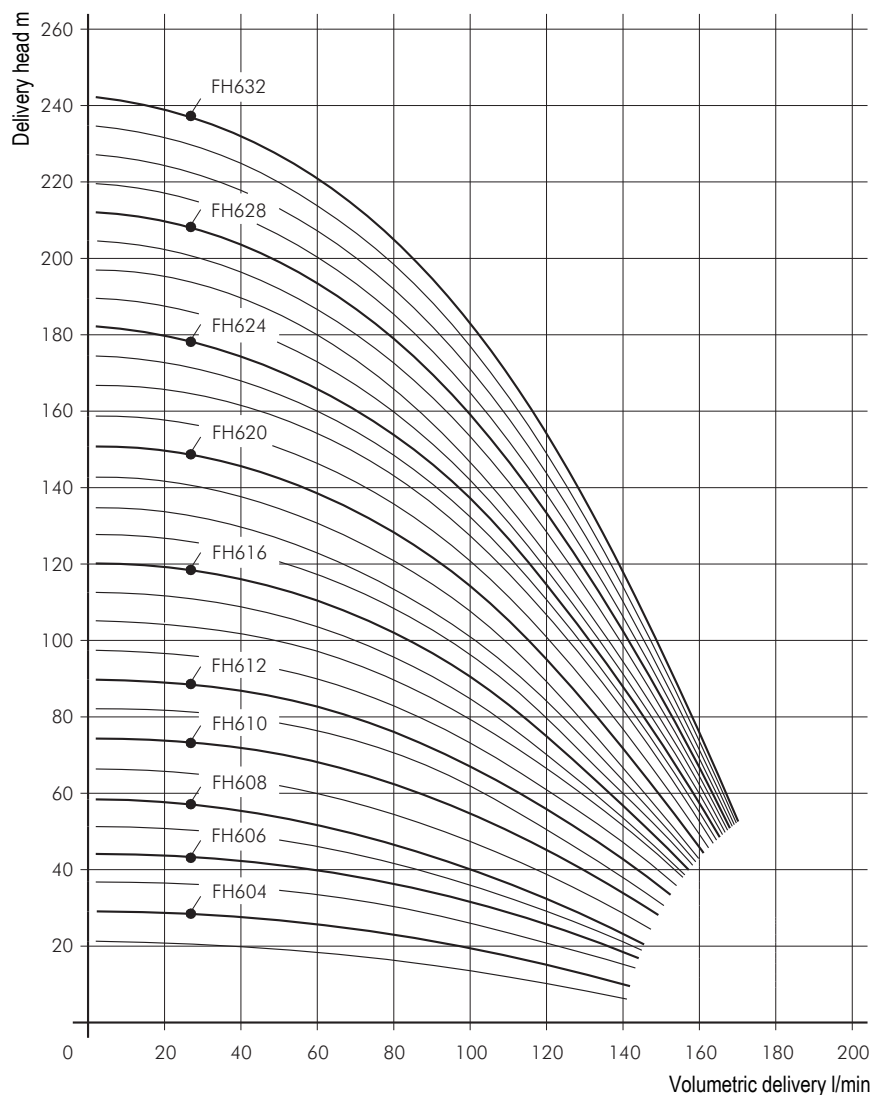

# Pressure Boosting Pumps



## FH11

Closed impellers

50 Hz

### FH1102...1121

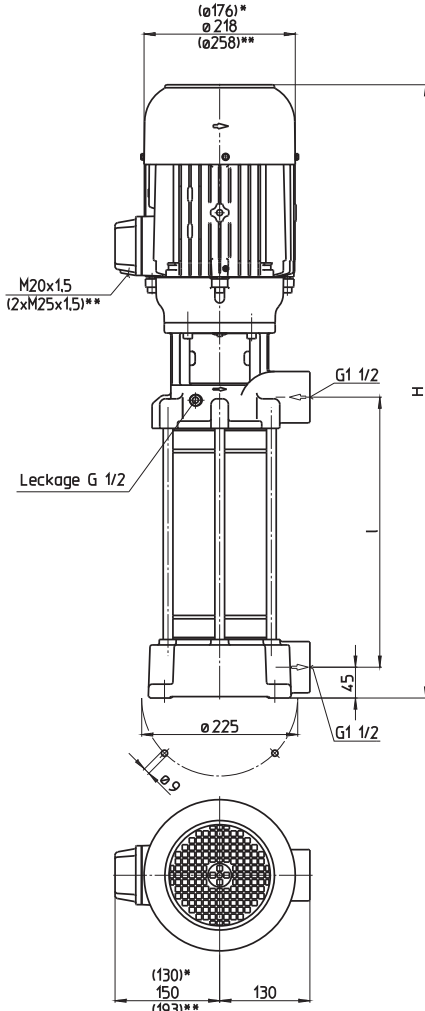

\*) Dimensions for FH1102...1107

\*\*\*) Dimensions for FH1111...1121

Type	Vol. del. at manom. del. head l/min / m	Height H mm	Length l mm	Weight kg	Power kW	Voltage 3~ V	Fre- quency Hz	Rated current A	Speed 1/min
<b>FH1102A18</b>	150/19	615	212	39	1.3	220-240 380-420	50 50	5.2 3.0	2850 2850
<b>FH1103A18</b>	150/29	615	212	40	1.5	220-240 380-420	50 50	6.6 3.8	2850 2850
<b>FH1104A28</b>	150/38	711	308	42					
<b>FH1105A28</b>	150/48	737	308	46	1.9	220-240 380-420	50 50	8.5 4.9	2850 2850
<b>FH1106A28</b>	150/58	737	308	47	2.2	220-240 380-420	50 50	9.2 5.3	2850 2850
<b>FH1107A31</b>	150/67	779	340	48	2.6	220-240 380-420	50 50	10.9 6.3	2850 2850
<b>FH1108A38</b>	150/78	897	404	61	3.3	220-240 380-420	50 50	13.8 8.0	2900 2900
<b>FH1109A38</b>	150/88	897	404	64	4.0	220-240 380-420	50 50	16.5 9.5	2900 2900
<b>FH1110A47</b>	150/98	993	500	66					
<b>FH1111A47</b>	150/106	1029	500	83	5.0	220-240 380-420	50 50	20.8 12.0	2900 2900
<b>FH1112A47</b>	150/118			84					
<b>FH1113A50</b>	150/128	1061	532	85	5.5	220-240 380-420	50 50	22.0 12.5	2900 2900
<b>FH1114A57</b>	150/138	1125	596	86					
<b>FH1115A57</b>	150/149	1162	596	95	7.5	220-240 380-420	50 50	29 17	2900 2900
<b>FH1116A66</b>	150/158	1258	682	98					
<b>FH1117A66</b>	150/168			99					
<b>FH1118A66</b>	150/178			100					
<b>FH1119A76</b>	150/188	1354	788	101					
<b>FH1120A76</b>	150/198			102					
<b>FH1121A76</b>	150/206	1404	788	106	10.0	220-240 380-420	50 50	40 23	2900 2900

## Pressure Boosting Pumps

series TH and FH use **closed impellers** in order to minimize power consumption and to optimize hydraulic pump efficiencies.

In addition, the TH series offers high pressures at short immersion depths.

Inline pumps of the series FH can be used as **boosting pumps** if provided with positive inlet pressure. This inlet pressure can be provided by the central coolant supply or a feed pump. In such a setup, pumps of the series FH can raise the incoming pressure by up to 26 bar.

For alternating machining using **internally** and **externally cooled tools**, these models are available with YYY-configured **pole-changing motor** (Dahlander) for optional changeover to **half speed** operation.

A **frequency converter** can be supplied for **special applications** or for matching the pump characteristic to a specific duty point.

See page "Control/Regulation" in the Technical Information section of this catalog for further information.



## Applications

Types of fluid  
 water  
 coolants  
 cooling/cutting oils  
 Kinematic viscosity  
 ...25 mm<sup>2</sup>/s (25 cSt)  
 Pumping temperature  
 0...80° C

## Construction

Pump body	cast iron
Cover	cast iron
Impellers	CrNi-steel
Shaft	CrNi-steel
Diffusers	CrNi-steel
Mechanical seal	SiC
O-rings	Viton

Optional:  
 Pole-changing motor 4 - 2 poles

Noise level  
 FH1102...FH1107 63 dBA  
 FH1108...FH1114 71 dBA  
 FH1115...FH1121 74 dBA

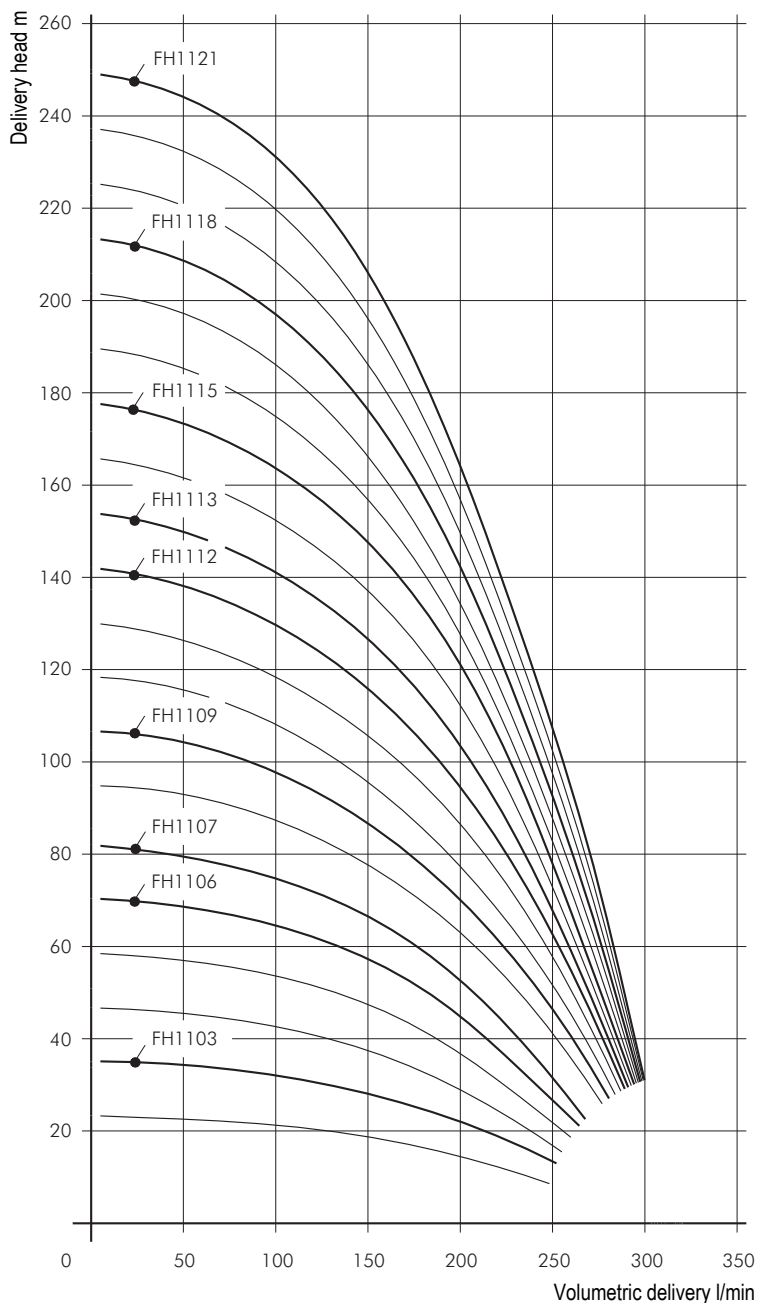







## Pressure Boosting Pumps

series TH and FH use **closed impellers** in order to minimize power consumption and to optimize hydraulic pump efficiencies.

In addition, the TH series offers high pressures at short immersion depths.

Inline pumps of the series FH can be used as **boosting pumps** if provided with positive inlet pressure. This inlet pressure can be provided by the central coolant supply or a feed pump. In such a setup, pumps of the series FH can raise the incoming pressure by up to 26 bar.

For alternating machining using **internally and externally cooled tools**, these models are available with YYY-configured **pole-changing motor** (Dahlander) for optional changeover to **half speed** operation.

**A frequency converter** can be supplied for **special applications** or for matching the pump characteristic to a specific duty point.

See page "Control/Regulation" in the Technical Information section of this catalog for further information.

## Applications

Types of fluid  
 water  
 coolants  
 cooling/cutting oils  
 Kinematic viscosity  
 ...25 mm<sup>2</sup>/s (25 cSt)  
 Pumping temperature  
 0...80° C

## Construction

Pump body	cast iron
Cover	cast iron
Impellers	CrNi-steel
Shaft	CrNi-steel
Diffusers	CrNi-steel
Mechanical seal	SiC
O-rings	Viton

Optional:  
 Pole-changing motor 4 - 2 poles

Noise level	
FH1402...FH1403	63 dBA
FH1404...FH1407	71 dBA
FH1408...FH1413	74 dBA
FH1414...FH1417	78 dBA

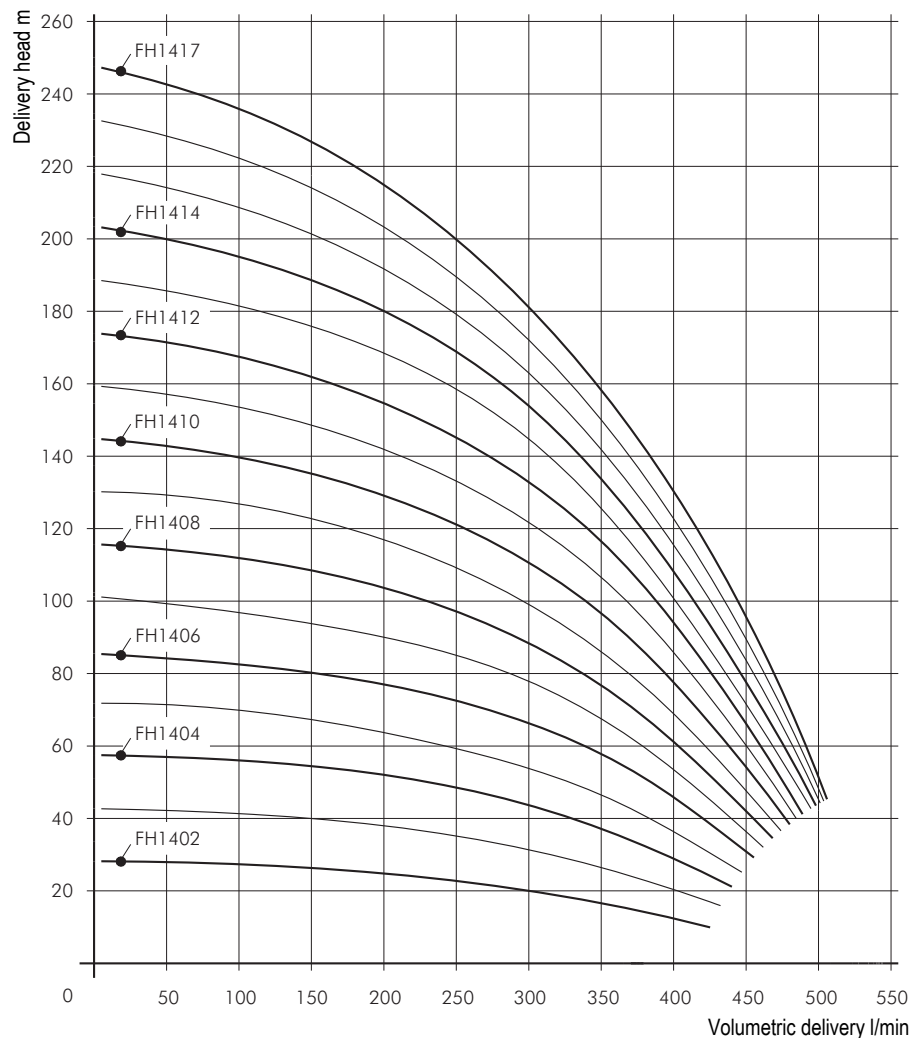

# Pressure Boosting Pumps

## FH2

Closed impellers

60 Hz

### FH203...230

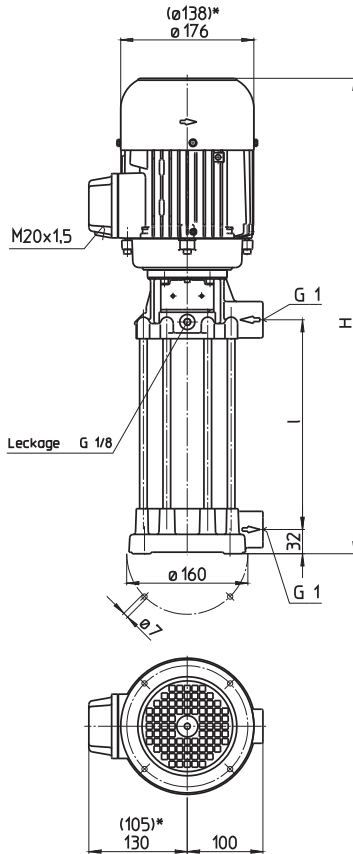

\*) Dimensions for FH203...FH215

Type	Vol. del. at manom. del. head l/min / m	Height H mm	Length l mm	Weight kg	Power kW	Voltage 3~ V	Fre- quency Hz	Rated current A	Speed 1/min
<b>FH203B19</b>	20/25	488	197	16.9	0.45	460	60	1.1	3200
<b>FH204B19</b>	20/30			17.0					
<b>FH205B19</b>	20/40	488	197	17.4	0.54	460	60	1.4	3300
<b>FH206B29</b>	20/50	588	297	17.9					
<b>FH207B29</b>	20/57	606	297	19.3	0.75	460	60	2.2	3300
<b>FH208B29</b>	20/64			19.4					
<b>FH209B29</b>	20/74			19.5					
<b>FH210B29</b>	20/81			19.6					
<b>FH211B39</b>	20/90	706	397	20.9	0.92	460	60	2.7	3300
<b>FH212B39</b>	20/98			21.0					
<b>FH213B39</b>	20/106			21.1					
<b>FH214B39</b>	20/113	726	397	22.1	1.1	460	60	2.9	3300
<b>FH215B39</b>	20/119			22.2					
<b>FH216B49</b>	20/127	849	497	29.9	1.3	460	60	3	3400
<b>FH217B49</b>	20/136	849	497	30.5	1.5	460	60	3.8	3400
<b>FH218B49</b>	20/146			30.6					
<b>FH219B49</b>	20/156			30.7					
<b>FH220B49</b>	20/164	849	497	31.2	1.7	460	60	4.1	3400
<b>FH221B59</b>	20/172	949	597	31.7					
<b>FH222B59</b>	20/182	973	597	35.7	1.9	460	60	4.9	3400
<b>FH223B59</b>	20/191			35.8					
<b>FH224B59</b>	20/200	973	597	36.4	2.2	460	60	5.3	3400
<b>FH225B59</b>	20/208			36.5					
<b>FH226B69</b>	20/216	1073	697	37.0					
<b>FH227B69</b>	20/224			37.1					
<b>FH228B69</b>	20/231	1083	697	37.5	2.6	460	60	6.3	3400
<b>FH229B69</b>	20/238			37.8					
<b>FH230B69</b>	20/245			37.9					

**Pressure Boosting Pumps**

Series TH and FH use **closed impellers** in order to minimize power consumption and to optimize hydraulic pump efficiencies.

In addition, the TH series offers high pressures at short immersion depths.

Inline pumps of the series FH can be used as **boosting pumps** if provided with positive inlet pressure. This inlet pressure can be provided by the central coolant supply or a feed pump. In such a setup, pumps of the series FH can raise the incoming pressure by up to 26 bar.

For alternating machining using **internally and externally cooled tools**, these models are available with YYY-configured **pole-changing motor** (Dahlander) for optional changeover to **half speed** operation.

A **frequency converter** can be supplied for **special applications** or for matching the pump characteristic to a specific duty point.

See page "Control/Regulation" in the Technical Information section of this catalog for further information.



**Applications**

- Types of fluid
  - water
  - coolants
  - cooling/cutting oils
- Kinematic viscosity
  - ...25 mm<sup>2</sup>/s (25 cSt)
- Pumping temperature
  - 0...80° C

**Construction**

- |                     |             |
|---------------------|-------------|
| Pump body           | cast iron   |
| Cover               | cast iron   |
| Impellers           | CrNi-steel  |
| Shaft               | CrNi-steel  |
| Diffusers           | CrNi-steel  |
| Mechanical seal     | SiC         |
| O-rings             | Viton       |
| Optional:           |             |
| Pole-changing motor | 4 - 2 poles |
| Pump body           | bronze      |
| Cover               | bronze      |

- |               |        |
|---------------|--------|
| Noise level   |        |
| FH203...FH215 | 61 dBA |
| FH216...FH230 | 66 dBA |

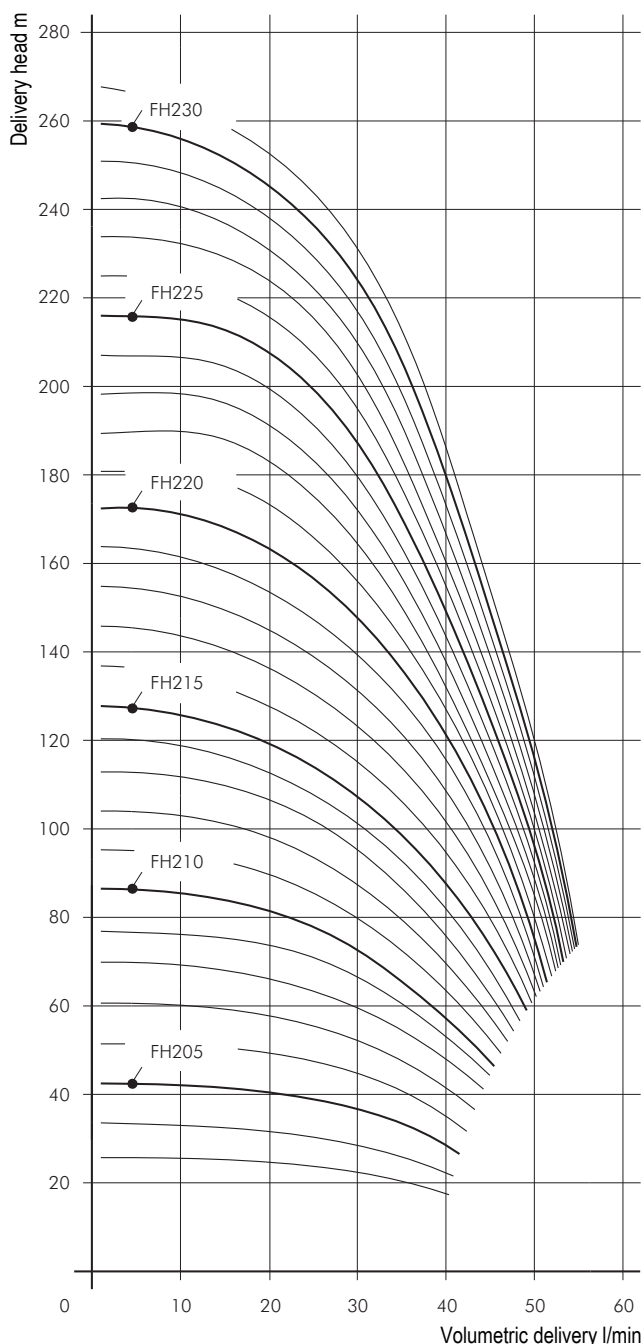

# Pressure Boosting Pumps

## FH4

Closed impellers

60 Hz

### FH403...423

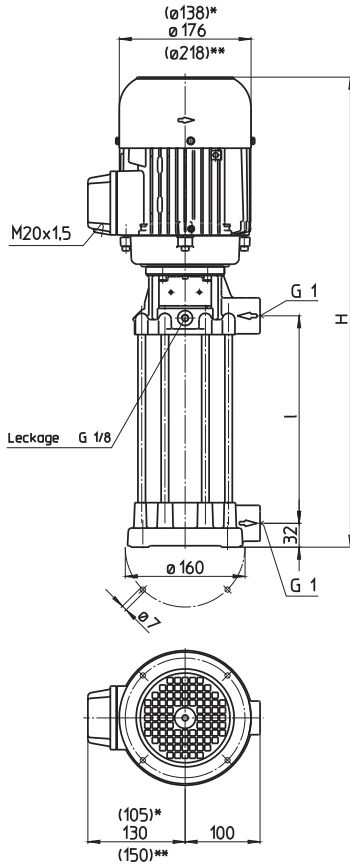

\*) Dimensions for FH403...FH408

\*\*) Dimensions for FH419...FH423

Type	Vol. del. at manom. del. head l/min / m	Height H mm	Length l mm	Weight kg	Power kW	Voltage 3~ V	Fre- quency Hz	Rated current A	Speed 1/min
<b>FH403B19</b>	40/29	488	197	17.2	0.54	460	60	1.4	3300
<b>FH404B19</b>	40/39	506	197	19.6	0.75	460	60	2.2	3300
<b>FH405B19</b>	40/49			19.7					
<b>FH406B29</b>	40/58	606	297	21.1	0.92	460	60	2.7	3300
<b>FH407B29</b>	40/68	626	297	22.1	1.1	460	60	2.9	3300
<b>FH408B29</b>	40/78			22.2					
<b>FH409B29</b>	40/88	649	297	29.5	1.3	460	60	3	3400
<b>FH410B29</b>	40/100	649	297	30.1	1.5	460	60	3.8	3400
<b>FH411B39</b>	40/110	749	397	30.6	1.7	460	60	4.1	3400
<b>FH412B39</b>	40/119			31.1					
<b>FH413B39</b>	40/129	773	397	35.1	1.9	460	60	4.9	3400
<b>FH414B39</b>	40/139	773	397	35.7	2.2	460	60	5.3	3400
<b>FH415B39</b>	40/150			35.8					
<b>FH416B49</b>	40/159	883	497	36.8	2.6	460	60	6.3	3400
<b>FH417B49</b>	40/170			36.9					
<b>FH418B49</b>	40/179			37.0					
<b>FH419B49</b>	40/192	938	497	47.2	3.3	460	60	8	3450
<b>FH420B49</b>	40/202			47.3					
<b>FH421B59</b>	40/214	1038	597	47.8					
<b>FH422B59</b>	40/224			47.9					
<b>FH423B59</b>	40/233			48.0					

**Pressure Boosting Pumps**

series TH and FH use **closed impellers** in order to minimize power consumption and to optimize hydraulic pump efficiencies. In addition, the TH series offers high pressures at short immersion depths. Inline pumps of the series FH can be used as **boosting pumps** if provided with positive inlet pressure. This inlet pressure can be provided by the central coolant supply or a feed pump. In such a setup, pumps of the series FH can raise the incoming pressure by up to 26 bar. For alternating machining using **internally and externally cooled tools**, these models are available with YYY-configured **pole-changing motor** (Dahlander) for optional changeover to **half speed** operation. **A frequency converter** can be supplied for **special applications** or for matching the pump characteristic to a specific duty point. See page "Control/Regulation" in the Technical Information section of this catalog for further information.



**Applications**

Types of fluid  
 water  
 coolants  
 cooling/cutting oils  
 Kinematic viscosity  
 ...25 mm<sup>2</sup>/s (25 cSt)  
 Pumping temperature  
 0...80° C

**Construction**

Pump body	cast iron
Cover	cast iron
Impellers	CrNi-steel
Shaft	CrNi-steel
Diffusers	CrNi-steel
Mechanical seal	SiC
O-rings	Viton
<b>Optional:</b>	
Pole-changing motor	4 - 2 poles
Pump body	bronze
Cover	bronze
<b>Noise level</b>	
FH403...FH408	61 dBA
FH409...FH418	66 dBA
FH419...FH423	75 dBA

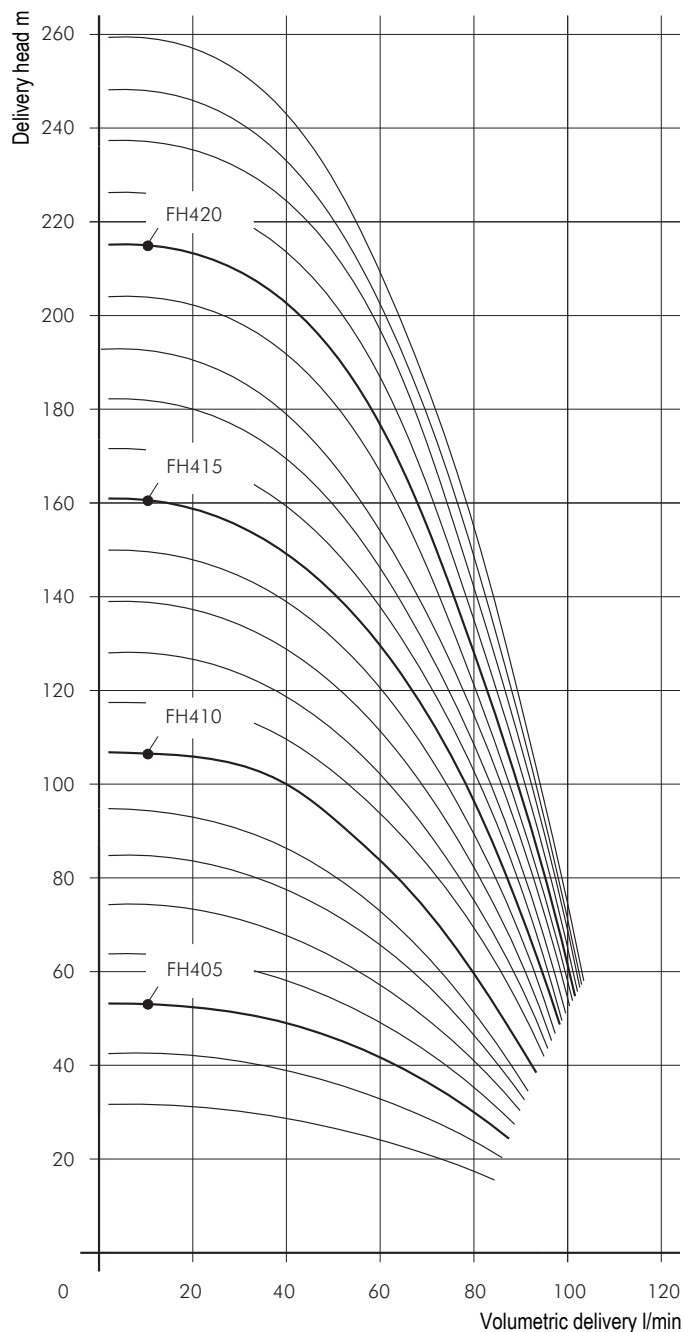

# Pressure Boosting Pumps

## FH6

Closed impellers



### FH603...624

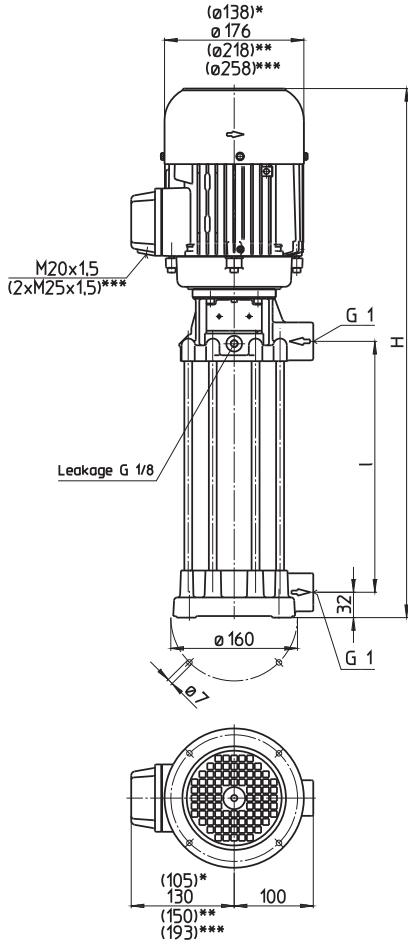

\*) Dimensions for FH603...FH605  
 \*\*) Dimensions for FH613...FH617  
 \*\*\*) Dimensions for FH618...FH624

Type	Vol. del. at manom. del. head l/min / m	Height H mm	Length l mm	Weight kg	Power kW	Voltage 3~ V	Fre- quency Hz	Rated current A	Speed 1/min
<b>FH603B19</b>	80/28	506	197	18.9	0.75	460	60	2.2	3300
<b>FH604B19</b>	80/38	506	197	20	0.92	460	60	2.7	3300
<b>FH605B24</b>	80/48	576	247	20.8	1.1	460	60	2.9	3300
<b>FH606B24</b>	80/58	599	247	27.9	1.5	460	60	3.8	3400
<b>FH607B29</b>	80/68	649	297	32.2	1.7	460	60	4.1	3400
<b>FH608B29</b>	80/78	673	297	36.3	1.9	460	60	4.9	3400
<b>FH609B34</b>	80/88	723	347	37	2.2	460	60	5.3	3400
<b>FH610B34</b>	80/98	733	347	37.6	2.6	460	60	6.3	3400
<b>FH611B39</b>	80/108	783	397	38.1					
<b>FH612B39</b>	80/118			38.2					
<b>FH613B49</b>	80/128	938	497	52.1	3.3	460	60	8	3450
<b>FH614B49</b>	80/139			52.2					
<b>FH615B49</b>	80/149			52.3					
<b>FH616B49</b>	80/159	938	497	54.8	4.0	460	60	9.5	3450
<b>FH617B59</b>	80/168	1038	597	55.3					
<b>FH618B59</b>	80/178	1074	597	71.9	5.0	460	60	12	3450
<b>FH619B59</b>	80/188			72.0					
<b>FH620B59</b>	80/198			72.1					
<b>FH621B69</b>	80/206	1174	697	72.6					
<b>FH622B69</b>	80/214			72.7					
<b>FH623B69</b>	80/222	1174	697	73.7	5.5	460	60	12.5	3450
<b>FH624B69</b>	80/232			73.8					

### Pressure Boosting Pumps

Series TH and FH use **closed impellers** in order to minimize power consumption and to optimize hydraulic pump efficiencies.

In addition, the TH series offers high pressures at short immersion depths.

Inline pumps of the series FH can be used as **boosting pumps** if provided with positive inlet pressure. This inlet pressure can be provided by the central coolant supply or a feed pump. In such a setup, pumps of the series FH can raise the incoming pressure by up to 26 bar.

For alternating machining using **internally and externally cooled tools**, these models are available with YYY-configured **pole-changing motor** (Dahlander) for optional changeover to **half speed** operation.

A **frequency converter** can be supplied for **special applications** or for matching the pump characteristic to a specific duty point.

See page "Control/Regulation" in the Technical Information section of this catalog for further information.

### Applications

- Types of fluid
  - water
  - coolants
  - cooling/cutting oils
- Kinematic viscosity
  - ...25 mm<sup>2</sup>/s (25 cSt)
- Pumping temperature
  - 0...80° C

### Construction

Pump body	cast iron
Cover	cast iron
Impellers	CrNi-steel
Shaft	CrNi-steel
Diffusers	CrNi-steel
Mechanical seal	SiC
O-rings	Viton
Optional:	
Pole-changing motor	4 - 2 poles
Pump body	bronze
Cover	bronze
Noise level	
FH603...FH605	61 dBA
FH606...FH612	66 dBA
FH613...FH624	75 dBA

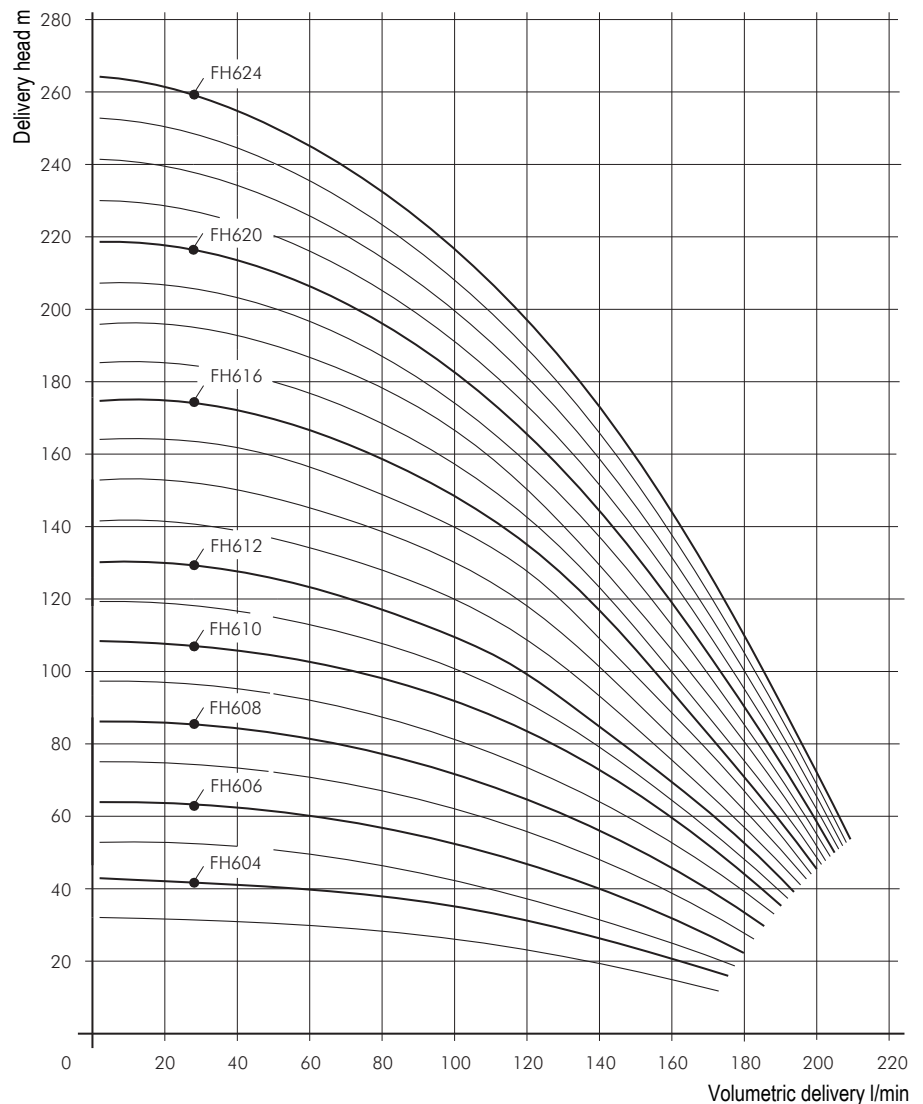

# Pressure Boosting Pumps

## FH11

Closed impellers



### FH1102...1115

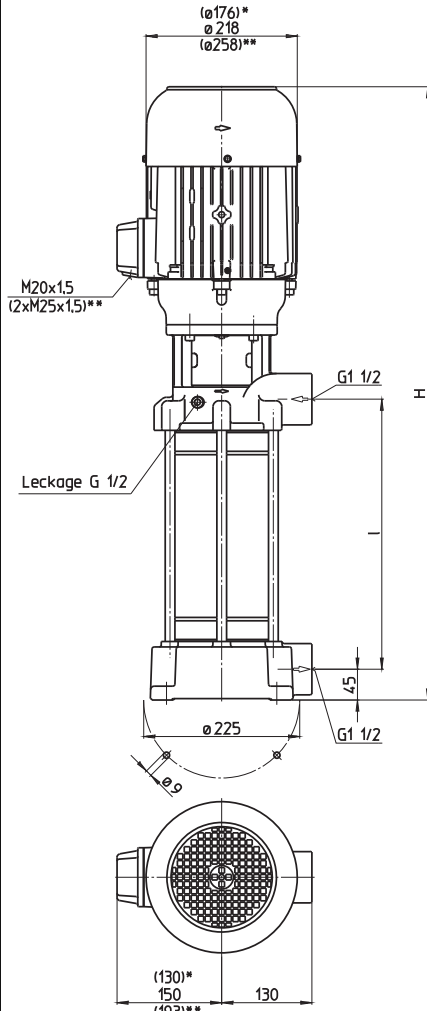

\*) Dimensions for FH1102...1104  
 \*\*) Dimensions for FH1107...1115

Type	Vol. del. at manom. del. head l/min / m	Height H mm	Length l mm	Weight kg	Power kW	Voltage 3~ V	Fre- quency Hz	Rated current A	Speed 1/min
<b>FH1102B18</b>	150/30	615	212	39	1.3	460	60	3	3400
<b>FH1103B18</b>	150/45	641	212	43	1.9	460	60	4.9	3400
<b>FH1104B28</b>	150/59	747	308	47	2.6	460	60	6.3	3400
<b>FH1105B28</b>	150/77	801	308	57	3.3	460	60	8	3450
<b>FH1106B28</b>	150/90	801	308	60	4.0	460	60	9.5	3450
<b>FH1107B31</b>	150/106	869	340	78	5.0	460	60	12	3450
<b>FH1108B38</b>	150/121	933	404	80					
<b>FH1109B38</b>	150/138	933	404	81	5.5	460	60	12.5	3450
<b>FH1110B47</b>	150/152	1066	500	91	7.5	460	60	17	3450
<b>FH1111B47</b>	150/166			92					
<b>FH1112B47</b>	150/180			93					
<b>FH1113B50</b>	150/198	1098	532	94					
<b>FH1114B57</b>	150/212	1212	596	109	10.0	460	60	23	3450
<b>FH1115B57</b>	150/230			110					



### Pressure Boosting Pumps

series TH and FH use **closed impellers** in order to minimize power consumption and to optimize hydraulic pump efficiencies. In addition, the TH series offers high pressures at short immersion depths. Inline pumps of the series FH can be used as **boosting pumps** if provided with positive inlet pressure. This inlet pressure can be provided by the central coolant supply or a feed pump. In such a setup, pumps of the series FH can raise the incoming pressure by up to 26 bar. For alternating machining using **internally and externally cooled tools**, these models are available with YYY-configured **pole-changing motor** (Dahlander) for optional changeover to **half speed** operation. **A frequency converter** can be supplied for **special applications** or for matching the pump characteristic to a specific duty point. See page "Control/Regulation" in the Technical Information section of this catalog for further information.



### Applications

Types of fluid  
 water  
 coolants  
 cooling/cutting oils  
 Kinematic viscosity  
 ...25 mm<sup>2</sup>/s (25 cSt)  
 Pumping temperature  
 0...80° C

### Construction

Pump body	cast iron
Cover	cast iron
Impellers	CrNi-steel
Shaft	CrNi-steel
Diffusers	CrNi-steel
Mechanical seal	SiC
O-rings	Viton
Optional: Pole-changing motor	4 - 2 poles
Noise level	
FH1102...FH1104	66 dBA
FH1105...FH1109	74 dBA
FH1110...FH1115	77 dBA

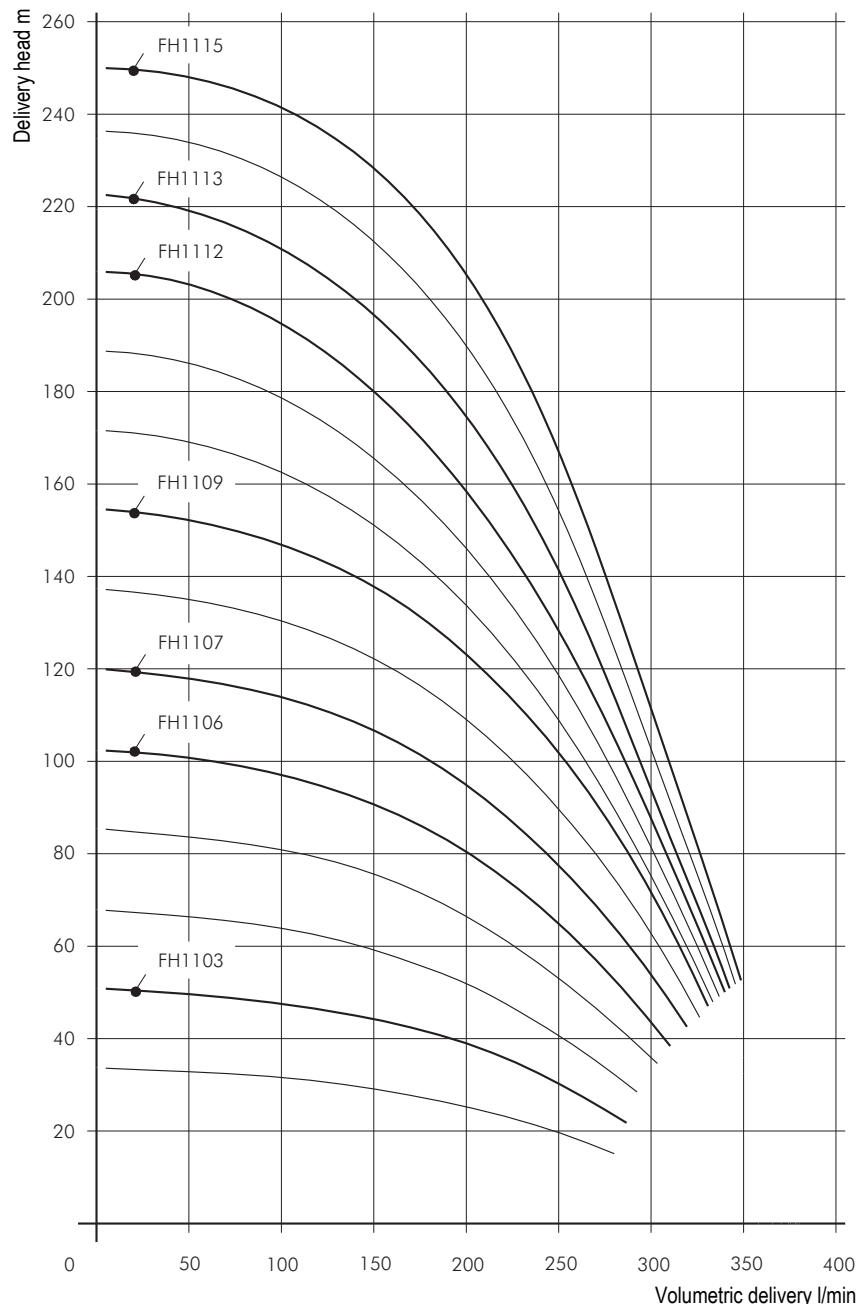

# Pressure Boosting Pumps

## FH14

Closed impellers



### FH1402...1412

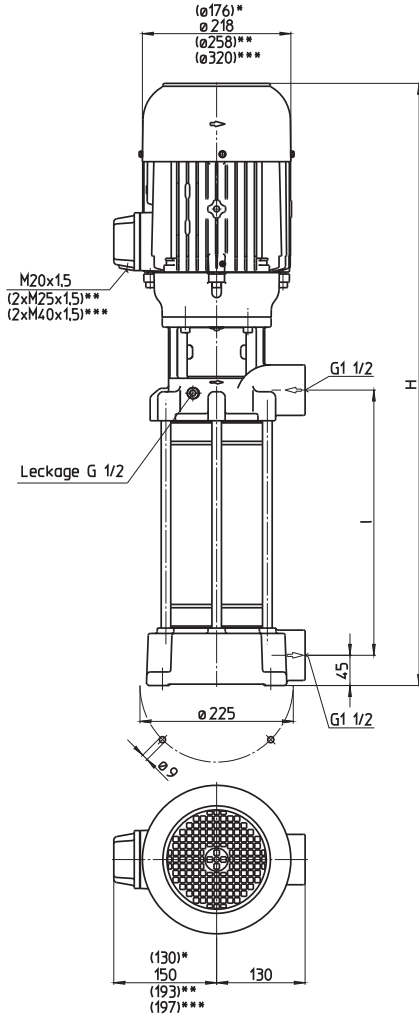

\*) Dimensions for FH1402  
 \*\*) Dimensions for FH1404...1408  
 \*\*\*) Dimensions for FH1409...1412

Type	Vol. del. at manom. del. head l/min / m	Height H mm	Length l mm	Weight kg	Power kW	Voltage 3~ V	Fre- quency Hz	Rated current A	Speed 1/min
<b>FH1402B18</b>	250/38	651	212	44	2.6	460	60	6.3	3400
<b>FH1403B28</b>	250/58	801	308	60	4.0	460	60	9.5	3450
<b>FH1404B28</b>	250/77	837	308	77	5.5	460	60	12.5	3450
<b>FH1405B38</b>	250/96	970	404	87	7.5	460	60	17	3450
<b>FH1406B38</b>	250/111			88					
<b>FH1407B47</b>	250/128	1116	500	106	10.0	460	60	23	3450
<b>FH1408B47</b>	250/147			107					
<b>FH1409B57</b>	250/165	1519	596	126	17.3	460	60	26	3545
<b>FH1410B57</b>	250/184			127					
<b>FH1411B66</b>	250/203	1615	692	130					
<b>FH1412B66</b>	250/222			131					

### Pressures Boosting Pumps

series TH and FH use **closed impellers** in order to minimize power consumption and to optimize hydraulic pump efficiencies. In addition, the TH series offers high pressures at short immersion depths. Inline pumps of the series FH can be used as **boosting pumps** if provided with positive inlet pressure. This inlet pressure can be provided by the central coolant supply or a feed pump. In such a setup, pumps of the series FH can raise the incoming pressure by up to 26 bar. For alternating machining using **internally and externally cooled tools**, these models are available with YYY-configured **pole-changing motor** (Dahlander) for optional changeover to **half speed** operation. **A frequency converter** can be supplied for **special applications** or for matching the pump characteristic to a specific duty point. See page "Control/Regulation" in the Technical Information section of this catalog for further information.

### Applications

Types of fluid  
 water  
 coolants  
 cooling/cutting oils  
 Kinematic viscosity  
 ...25 mm<sup>2</sup>/s (25 cSt)  
 Pumping temperature  
 0...80° C

### Construction

Pump body	cast iron
Cover	cast iron
Impellers	CrNi-steel
Shaft	CrNi-steel
Diffusers	CrNi-steel
Mechanical seal	SiC
O-rings	Viton
Optional:	
Pole-changing motor	4 - 2 poles
Noise level	
FH1402	66 dBA
FH1403...FH1404	74 dBA
FH1405...FH1408	77 dBA
FH1409...FH1412	81 dBA

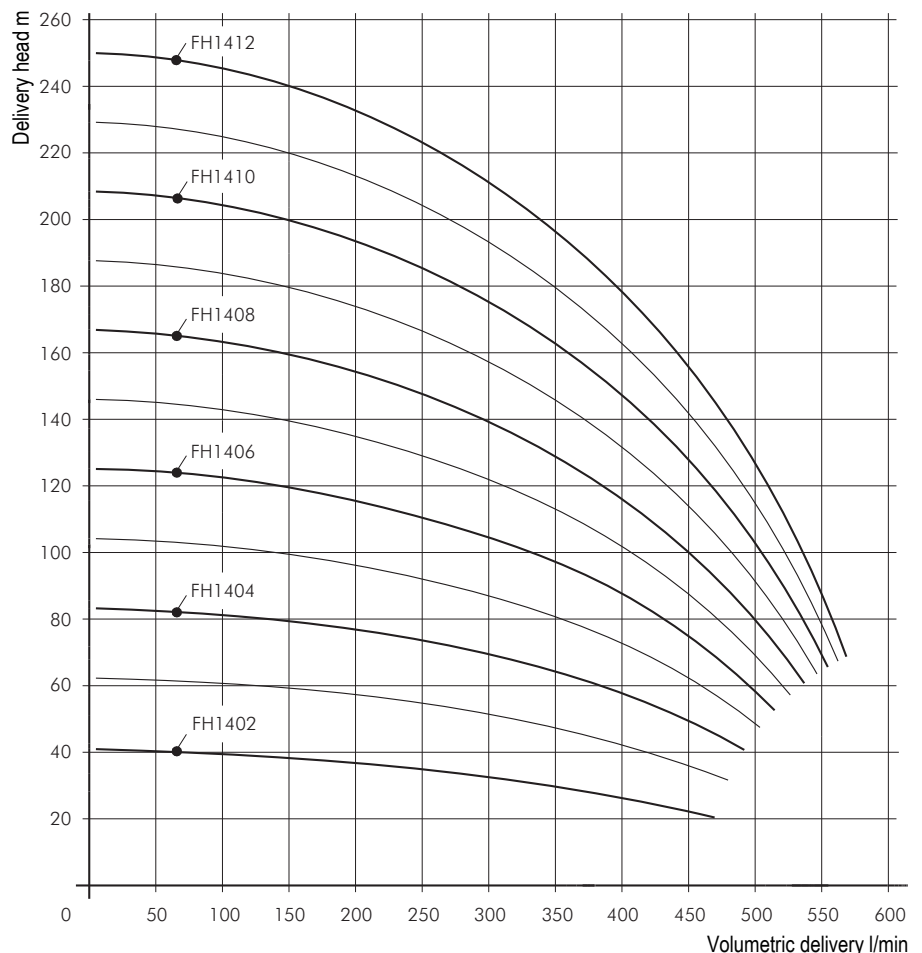

# Immersion Pumps

## TC260, TC460

### Closed impellers

#### TC260/460...1150 TC460/320...870

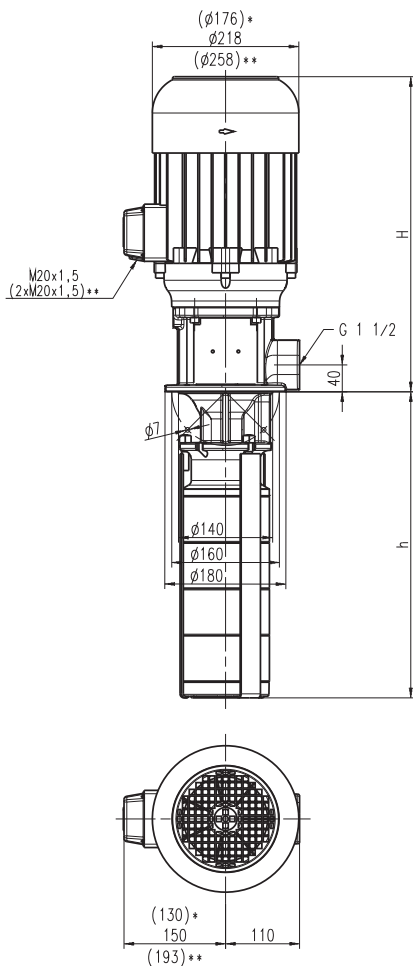

Type	Vol. del. at manom. del. head l/min / m	Height H mm	Depth of im- mersion h mm	Weight kg	Power kW	Voltage 3 ~ V	Fre- quency Hz	Rated current A	Speed 1/min
<b>TC260/460</b>	250/30	415	455	41	2.6	220-240 380-420 460	50 50 60	10.9 6.3 6.3	2850 2850 3450
<b>TC260/600</b>	250/50	468	593	57	4.0	220-240 380-420 460	50 50 60	16.5 9.5 9.5	2900 2900 3450
<b>TC260/690</b>	250	504	685	73	5.5	220-240 380-420 460	50 50 60	22.0 12.5 12.5	2900 2900 3450
<b>TC260/920</b>	250/95	542	915	93	7.5	220-240 380-420 460	50 50 60	29 17 17	2900 2900 3450
<b>TC260/1150</b>	250/130	592	1145	101	10.0	220-240 380-420 460	50 50 60	40 23 23	2900 2900 3450
<b>TC460/320</b>	450/15	405	317	36	2.2	220-240 380-420 460	50 50 60	9.2 5.3 5.3	2850 2850 3400
<b>TC460/390</b>	450/24	468	386	49	3.3	220-240 380-420 460	50 50 60	13.8 8.0 8.0	2900 2900 3450
<b>TC460/460</b>	450/34	468	455	55	4.0	220-240 380-420 460	50 50 60	16.5 9.5 9.5	2900 2900 3450
<b>TC460/530</b>	450/42	504	524	69	5.5	220-240 380-420 460	50 50 60	22.0 12.5 12.5	2900 2900 3450
<b>TC460/740</b>	450/69	542	731	88	7.5	220-240 380-420 460	50 50 60	29 17 17	2900 2900 3450
<b>TC460/870</b>	450/90	592	869	103	10.0	220-240 380-420 460	50 50 60	40 23 23	2900 2900 3450

#### STC260, STC460

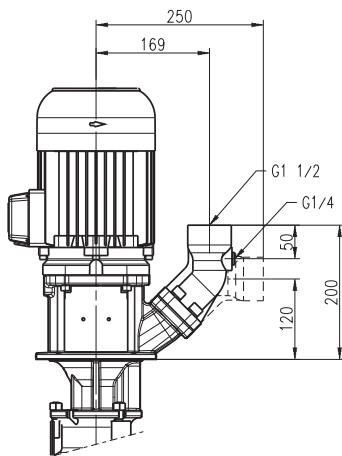

\*) Dimensions for TC260/460, TC460/320

\*\*) Dimensions for TC260/690 - 1150,  
TC460/530 - 870

### Immersion Pumps

The immersed parts of types TC260 to TC460 are made of stainless steel. They are designed for use on **central coolant systems** and CNC machining centers with **internally cooled tools**.

**Extended length is possible.** See mechanical/hydraulic features within the technical information section.

### Applications

Types of fluid  
coolants  
cooling/cutting oils  
Kinematic viscosity  
...30 mm<sup>2</sup>/s (30 cSt)  
Pumping temperature  
0...80° C

### Construction

Pump body	cast iron
Intake strainer	CrNi-steel
Impellers	CrNi-steel
Shaft	Cr-steel
Diffusers	CrNi-steel
Mechanical seal	SiC

Optional:  
Pole-changing motor 4 - 2 poles

Noise level	
TC260/460	63 dBA
TC460/320	70 dBA
TC260/600...TC260/690	70 dBA
TC460/390...TC460/530	70 dBA
TC260/920...TC260/1150	74 dBA
TC460/740...TC460/870	74 dBA

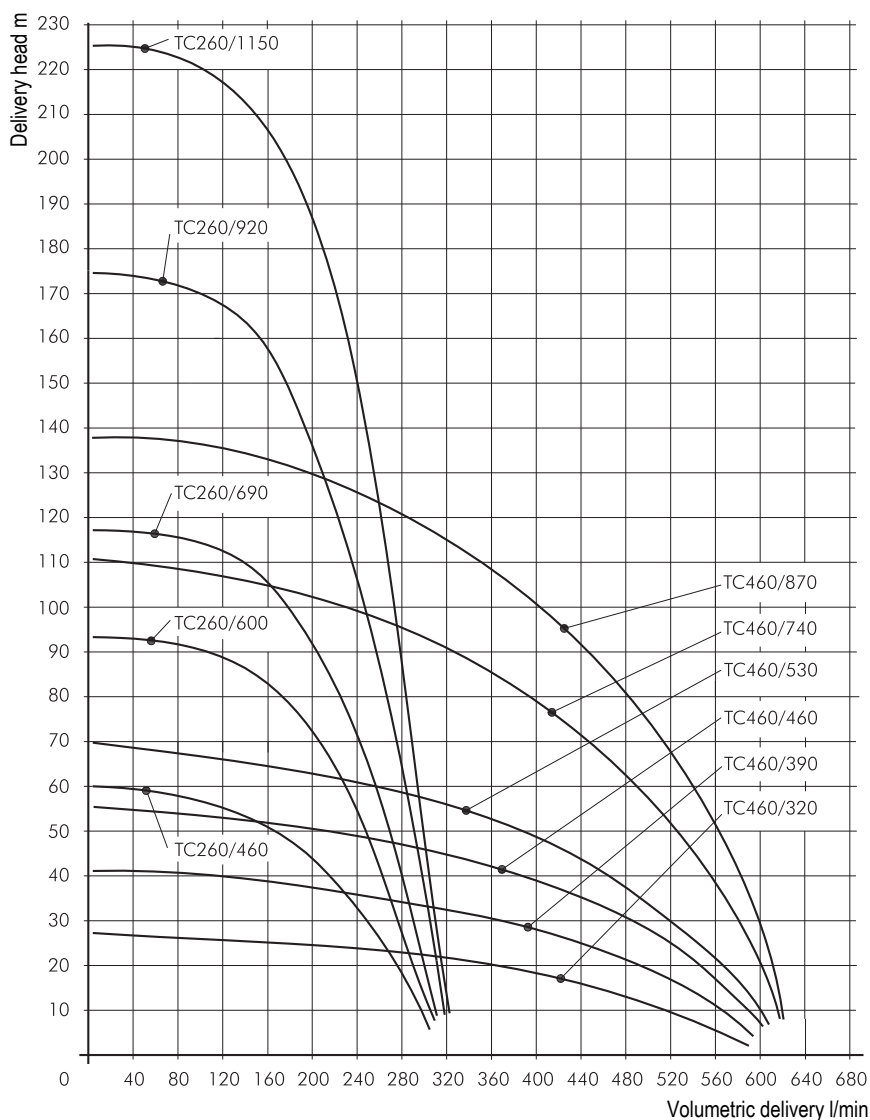

# Immersion Pumps in Plastics

## KTF25...54, KTF81...83

Semi-open impellers

### KTF25, 40, 51

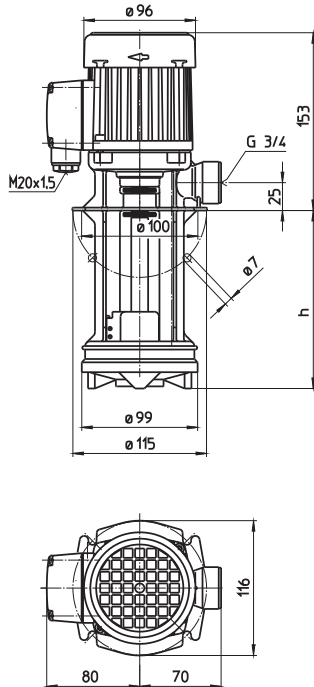

### KTF52, 53, 54 KTF81, 82, 83

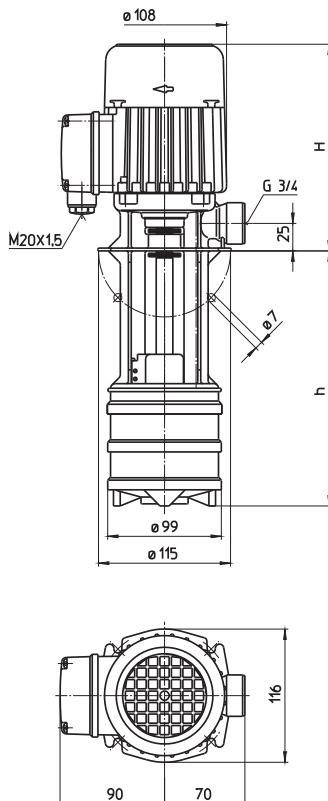

Type	Vol. del. at manom. del. head l/min / m	Height H mm	Depth of immersion h mm	Weight kg	Power kW	Voltage 3 ~ V	Fre- quency Hz	Rated current A	Speed 1/min
<b>KTF25/120</b>	25/2	153	118	2.4	0.045	220-240	50	0.33	2800
	170		168	2.5					
	220		218	2.6					
	270		268	2.8					
<b>KTF40/120</b>	25/3	153	118	2.5	0.055	220-240	50	0.35	2800
	170		168	2.6					
	220		218	2.7					
	270		268	2.9					
<b>KTF51/120</b>	25/5	153	118	2.6	0.075	220-240	50	0.38	2700
	170		168	2.7					
	220		218	2.8					
	270		268	3.0					
<b>KTF52/150</b>	25/8	181	151	3.0	0.14	220-240	50	0.71	2700
	200		201	3.1					
	250		251	3.2					
	300		301	3.4					
<b>KTF53/190</b>	25/12	181	184	3.7	0.22	220-240	50	0.95	2700
	240		234	3.8					
	290		284	3.9					
	340		334	4.1					
<b>KTF54/220</b>	25/17	214	217	4.7	0.28	220-240	50	1.4	2700
	270		267	4.9					
	320		317	5.1					
<b>KTF81/120</b>	30/6	181	118	2.8	0.14	220-240	50	0.71	2700
	170		168	2.9					
	220		218	3.0					
	270		268	3.2					
<b>KTF82/150</b>	30/11	181	151	3.5	0.22	220-240	50	0.95	2700
	200		201	3.6					
	250		251	3.7					
	300		301	3.9					
<b>KTF83/190</b>	30/15	214	184	4.5	0.28	220-240	50	1.4	2700
	240		234	4.6					
	290		284	4.8					
	340		334	5.0					

### Immersion Pumps in Plastics

**series KTF** are suitable for various **water supply problems**.

These pumps are also suitable for a wide range of **chemical liquids**.

No shaft seal is required, due to the construction.

### Applications

Types of fluid

water; warm, cold, with and without chemical admixtures, distilled, de-ionized

Kinematic viscosity

...12 mm<sup>2</sup>/s (12 cSt)

Pumping temperature

-10...+60° C

### Construction

Pump body	PPS
Cover	PPS
Impellers	PPS
Shaft	1.4104

Optional: Shaft	CrMo
--------------------	------

Optional:  
These models are also available with **single phase motor**.

Noise level	
KTF25...KTF51	47 dBA
KTF52...KTF83	48 dBA

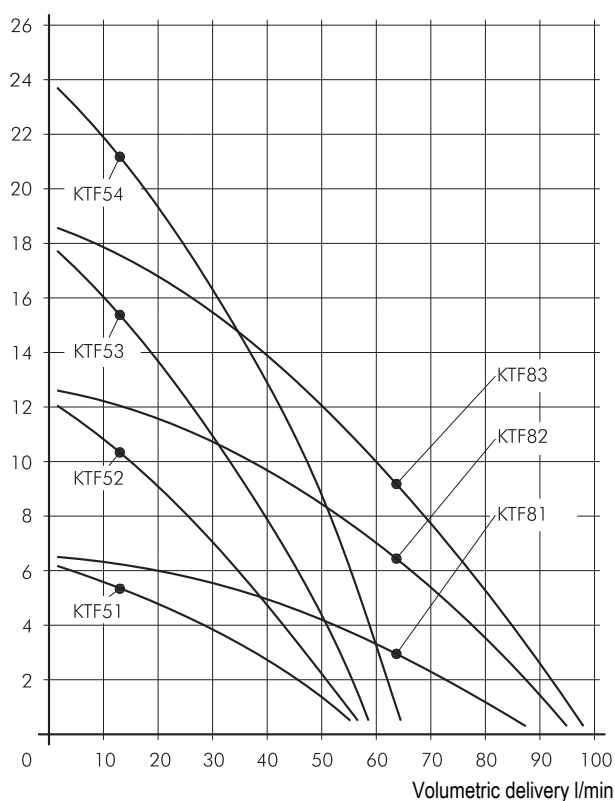
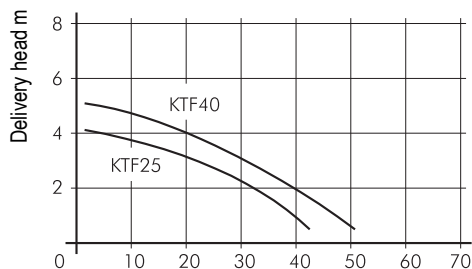

# Immersion Pumps in Plastics

## KTF151...303, KTB200

Semi-open impellers

### KTF151...153

### KTF301...303

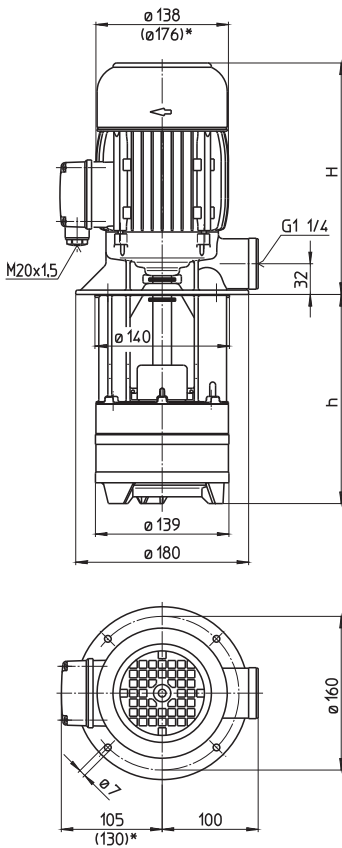

### KTB200

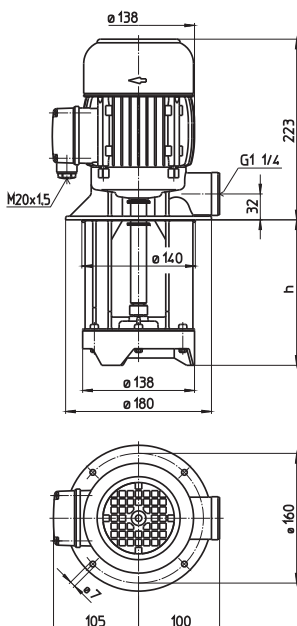

\*) Dimensions for KTF153, KTF302, 303

Type	Vol. del. at manom. del. head l/min / m	Height H mm	Depth of immersion h mm	Weight kg	Power kW	Voltage 3 ~ V	Fre- quency Hz	Rated current A	Speed 1/min
<b>KTF151/140</b>	100/10	223	140	7.0	0.53	220-240	50	2.25	2750
<b>220</b>			220	7.4					
<b>290</b>			290	7.8					
<b>370</b>			370	8.2					
<b>KTF152/180</b>	100/20	261	180	9.4	1.1	220-240	50	5.0	2700
<b>260</b>			260	9.8					
<b>330</b>			330	10.2					
<b>410</b>			410	10.6					
<b>KTF153/220</b>	100/32	318	220	19.5	1.5	220-240	50	6.6	2850
<b>300</b>			300	20.0					
<b>370</b>			370	20.5					
<b>450</b>			450	21.0					
<b>KTF301/140</b>	180/10	261	140	9.8	1.1	220-240	50	5.0	2700
<b>220</b>			220	10.1					
<b>290</b>			290	10.5					
<b>370</b>			370	10.9					
<b>KTF302/180</b>	180/20	318	180	19.0	1.5	220-240	50	6.6	2850
<b>260</b>			260	19.5					
<b>330</b>			330	20.0					
<b>410</b>			410	20.5					
<b>KTF303/220</b>	180/33	343	220	23.0	1.9	220-240	50	8.5	2850
<b>300</b>			300	23.5					
<b>370</b>			370	24.0					
<b>450</b>			450	24.5					
<b>KTB200/120</b>	210/2	223	120	6.2	0.55	220-240	50	2.50	2750
<b>200</b>			200	6.7					
<b>270</b>			270	7.2					
<b>350</b>			350	7.7					
					0.55	380-420	50	1.45	2750
					0.55	460	60	1.45	3250



### Immersion Pumps in Plastics

series **KTF** and **KTB** are suitable for various **water supply problems**.

These pumps are also suitable for a wide range of **chemical liquids**.

No shaft seal is required, due to the construction.

### Applications

#### Types of fluid

water; warm, cold, with and without chemical admixtures, distilled, de-ionized

#### Kinematic viscosity

...12 mm<sup>2</sup>/s (12 cSt)

#### Pumping temperature

-10...+60° C

### Construction

Pump body	POM
Cover	PPS
Impellers	POM (KTB200) PPS
Shaft	POM (KTB200) 1.4104
Optional: Shaft	CrMo

#### Noise level

KTF151...KTF152	60 dBA
KTF301	
KTB200	
KTF153	65 dBA
KTF302...KTF303	

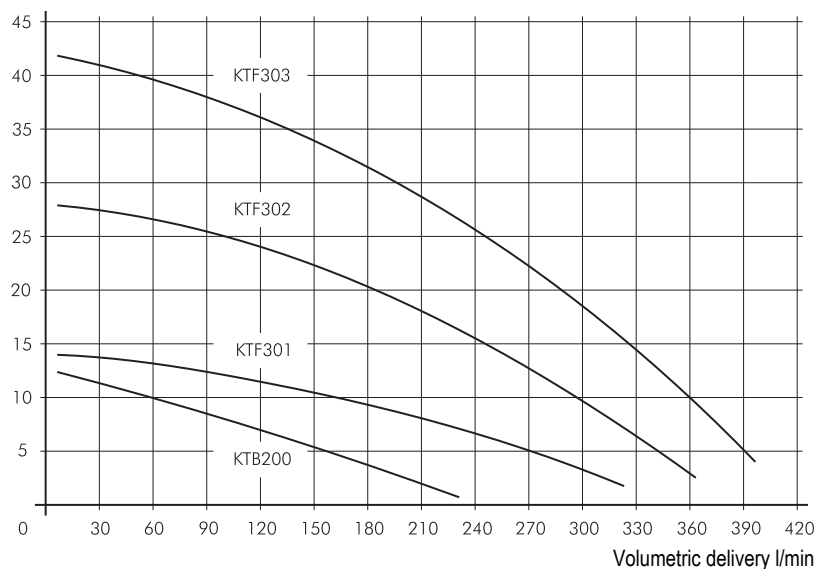
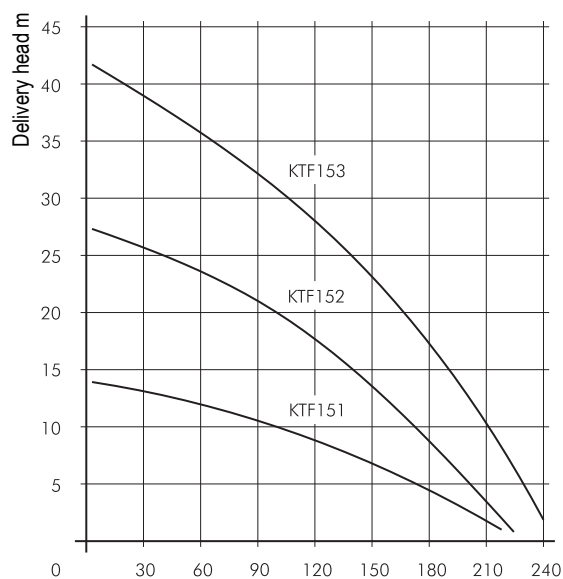

# Miniature Centrifugal Pumps

## KC21...45 / KC60

Open/peripheral impellers

### KC21, 31, 35, 45 self-priming

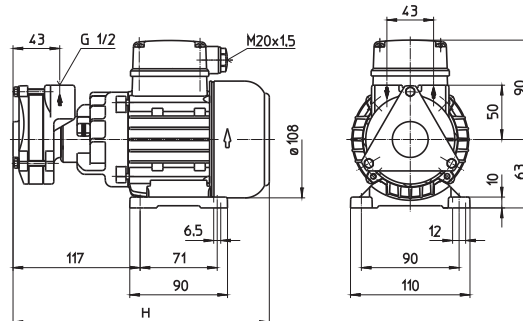

### KC60 self-priming

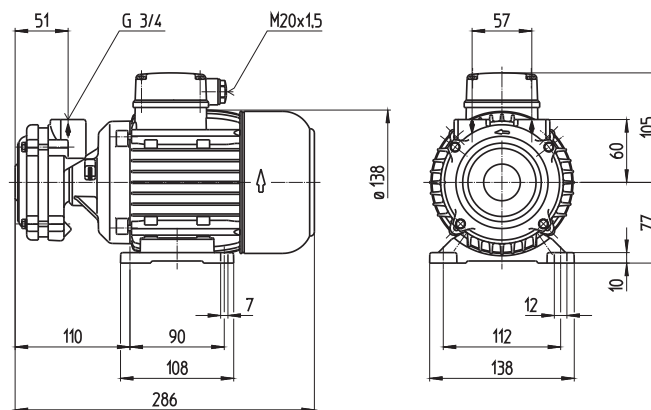

Type	Vol. del. at manom. del. head l/min / m	Dimensions H mm	Weight kg	Power kW	Voltage 3 ~ V	Fre- quency Hz	Rated current A	Speed 1/min
<b>KC21</b>	2/17	236	5.2	0.25	220-240 380-420	50 50	1.2 0.7	2700 2700
<b>KC31</b>	2/27	270	6	0.3	220-240 380-420	50 50	1.55 0.90	2700 2700
<b>KC35</b>	2/28	236	5.2	0.25	220-240 380-420	50 50	1.2 0.7	2700 2700
<b>KC45</b>	2/38	270	6	0.3	220-240 380-420	50 50	1.55 0.90	2700 2700
<b>KC60</b>	2/45	286	10.5	0.92	220-240 380-420 460	50 50 60	4.7 2.7 2.7	2700 2700 3300

### Miniature Centrifugal Pumps

series **KC** are suitable for pumping thin-bodied fluids.

They operate according to the bypass duct principle, with self-priming function following initial priming.

### Applications

Types of fluid  
 water  
 coolants  
 fuel oil

Kinematic viscosity  
 ...12 mm<sup>2</sup>/s (12 cSt)

Pumping temperature  
 0...80° C

Suction height  
 2 m without foot-located valve  
 6 m with foot-located valve

### Construction

Cover	bronze
Impeller	brass
Shaft	Cr-steel
Gasket	
Noise level	
KC35	57 dBA
KC45	60 dBA
KC21...KC31	63 dBA
KC60	65 dBA

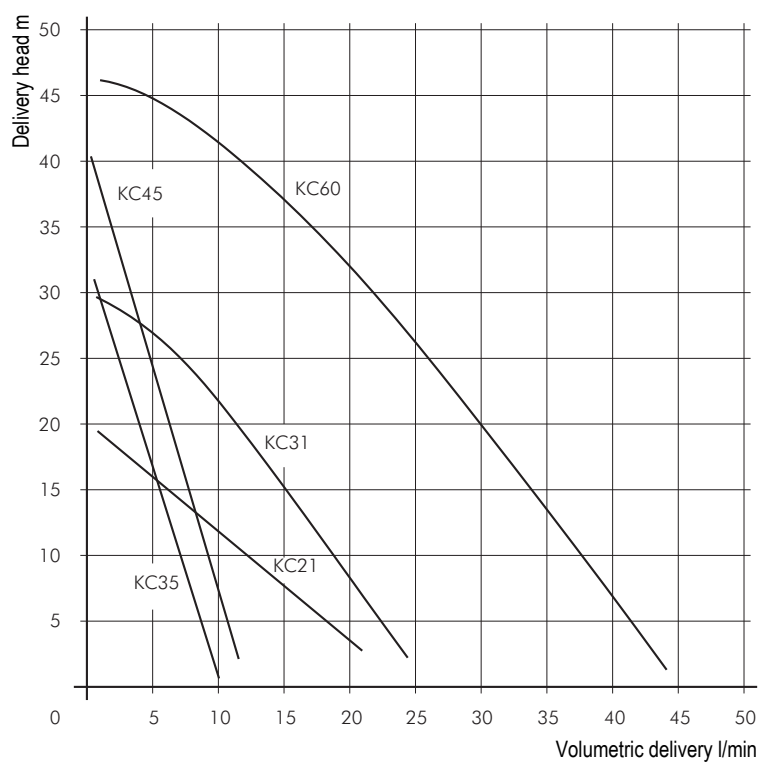

# Suction Pumps

## SB20...60

Open impellers

### SB20, 40

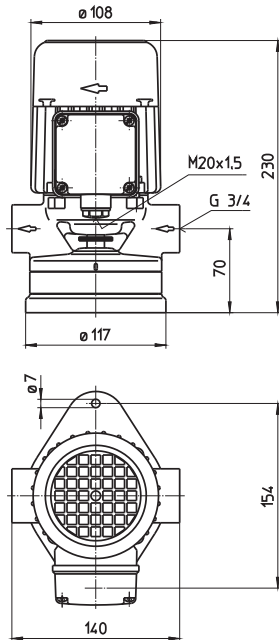

### SB60

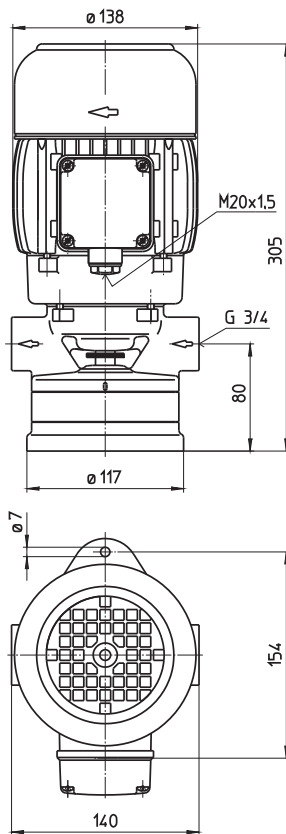

Type	Vol. del. at manom. del. head l/min /m	Weight kg	Power kW	Voltage 3~ V	Fre- quency Hz	Rated current A	Speed 1/min
<b>SB20</b>	20/2	5.8	0.14	220-240	50	0.71	2700
				380-420	50	0.41	2700
				460	60	0.41	3200
<b>SB40</b>	2/40	6.4	0.22	220-240	50	0.95	2700
				380-420	50	0.55	2700
				460	60	0.55	3200
<b>SB60</b>	2/60	9.9	0.63	220-240	50	2.6	2750
				380-420	50	1.5	2750
				460	60	1.5	3250

### Suction Pumps

are self-priming following the initial priming, and operate according to the bypass duct principle. We recommend pump models featuring bronze body elements for pumping water without anticorrosion additives.

The dimensions are based on standard specification **EN 12157**.

### Applications

Types of fluid  
 coolants  
 cooling/cutting oils  
 fuel oil  
 water (with anticorrosive additive)  
 Kinematic viscosity  
 ...60 mm<sup>2</sup>/s (60 cSt)  
 Suction height  
 1 - 2 m without foot-located valve  
 4 - 6 m with foot-located valve

### Construction

Pump body	cast iron
Cover	cast iron
Impeller	brass
Shaft	steel
Mechanical seal	graphite based
O-rings	Viton
Optional:	
Pump body	bronze (SB20...SB40)
Cover	bronze (SB20...SB40)
Impeller	CrNi-steel
Noise level	
SB20...SB40	54 dBA
SB60	64 dBA

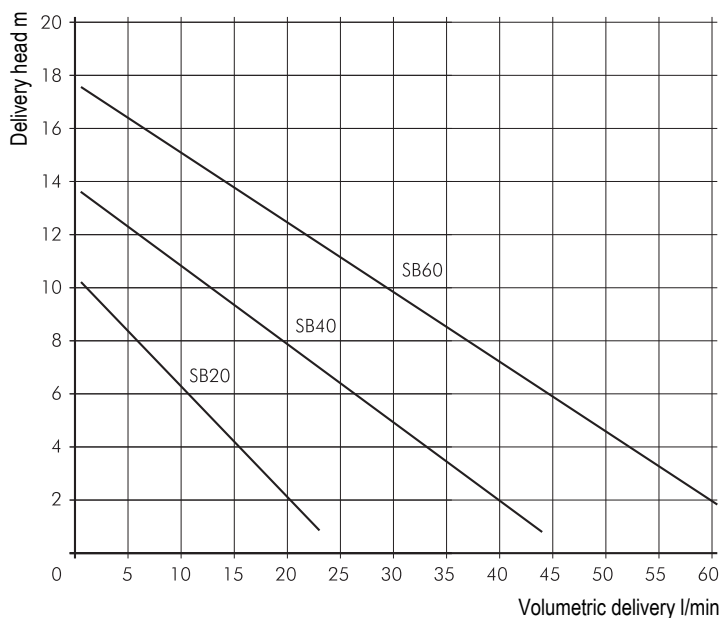

## TB...-M

### Semi-open impellers

#### TB40-M, TB63-M TB100-M

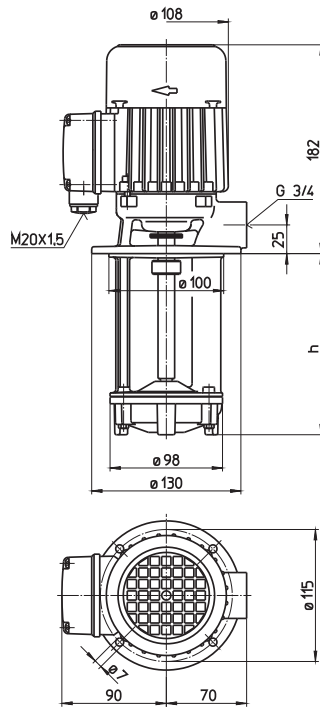

Type	Vol. del. at manom. del. head l/min /m	Depth of im- mersion h mm	Weight kg	Power kW	Voltage 3~ V	Fre- quency Hz	Rated current A	Speed 1/min
<b>TB40/120-M</b>	40/2	120	4.6	0.14	220-240	50	0.71	2700
<b>170-M</b>		170	5.1		380-420	50	0.41	2700
<b>220-M</b>		220	5.5		460	60	0.41	3200
<b>270-M</b>		270	6.0					
<b>350-M</b>		350	6.9					
<b>TB63/120-M</b>	63/2	130	4.9	0.14	220-240	50	0.71	2700
<b>170-M</b>		180	5.3		380-420	50	0.41	2700
<b>220-M</b>		230	5.7		460	60	0.41	3200
<b>270-M</b>		280	6.2					
<b>350-M</b>		360	7.1					
<b>TB100/120-M</b>	75/2	130	5.3	0.22	220-240	50	0.95	2700
<b>170-M</b>		180	5.8		380-420	50	0.55	2700
<b>220-M</b>		230	6.2		460	60	0.55	3200
<b>270-M</b>		280	6.7					
<b>350-M</b>		360	7.4					

### Immersion Pumps

are plain centrifugal pumps with the impeller fitted on the driving shaft extension. They are mounted on top of the container, the pump extension being immersed in the coolant.

The dimensions are based on standard specification **EN 12157**.

The maximum coolant level must stay a few mm/inches below the mounting flange.

### Applications

Types of fluid  
freezing medium, cooling oils  
other fluids on request

Kinematic viscosity  
...90 mm<sup>2</sup>/s (90 cSt)

Pumping temperature

### Construction

Pump body	cast iron
Cover	cast iron
Impeller	brass
Shaft	steel
Optional:	
Cover	cast iron with thread
Impeller	cast iron

On request:  
All parts having contact with the fluid are made of bronze.

Optional:  
The models of TB...-M are also available with **single phase motor**.

Noise level	
TB40-M...TB100-M	54 dBA

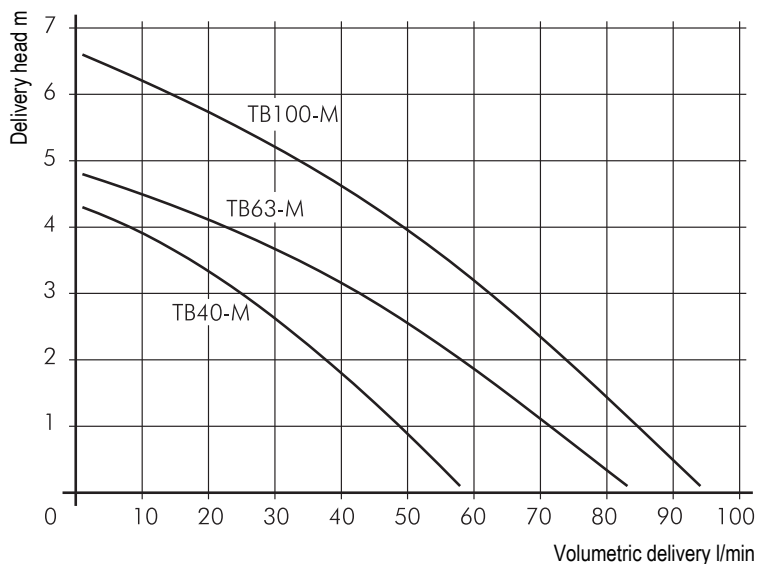

# Miniature Centrifugal Pumps

## B401...501

Peripheral impellers

50 Hz

### B401...501 Immersion Version

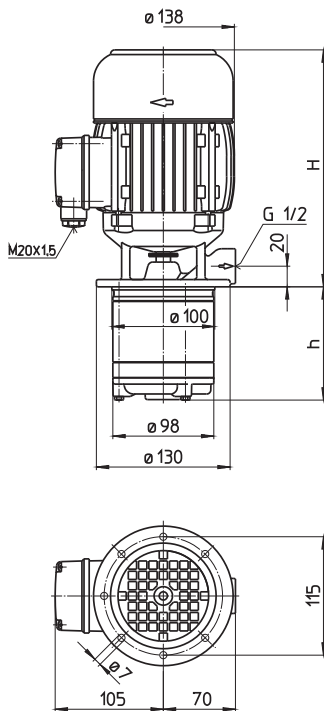

### B401...501 Base-mounted Version

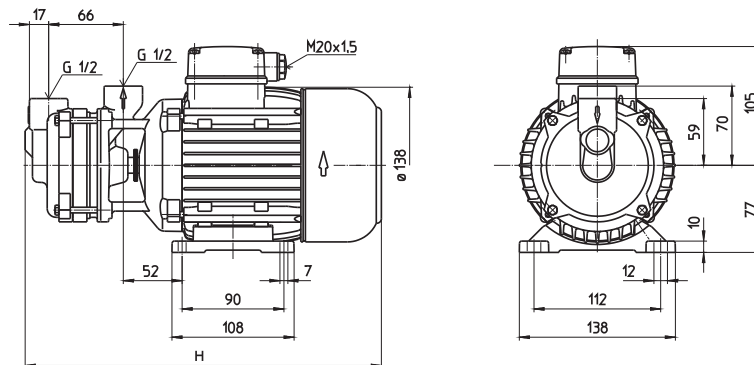

Type	Vol. del. at manom. del. head l/min / m	h mm	Weight kg	Power kW	Voltage 3 ~ V	Fre- quency Hz	Rated current A	Speed 1/min
<b>B401/110</b>	10/30	110	9	0.63	220-240	50	2.6	2750
<b>B401-F</b>		67						
<b>B501/110</b>	10/45	110	11	0.85	220-240	50	4.3	2800
<b>B501-F</b>		67						





## Miniature Centrifugal Pumps

Series B401 ...501 are suitable for pumping **clean fluids** up to 140° C temperature and 5 bar system-pressure.

For open circuits see immersion pumps TS12...24.

The minimum liquid level for immersion pumps of the B-series installed vertically must reach the lower impeller.

## Applications

Types of fluid  
water up to 140° C at 5 bar system-pressure

Pumping temperature  
...+ 140° C

## Construction

Pump body	bronze
Cover	bronze
Impeller	brass
Shaft	Cr-steel
Optional:	
Cover	CrNi-steel
Impeller	CrNi-steel

Noise level	
B401...B501	65 dBA

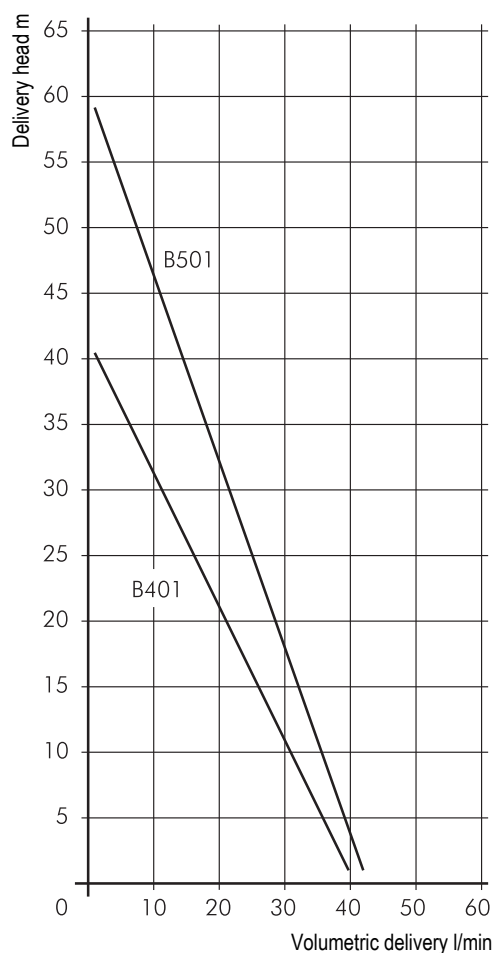

# Miniature Centrifugal Pumps

## BMK3...BMK4

Peripheral impellers

### BMK3

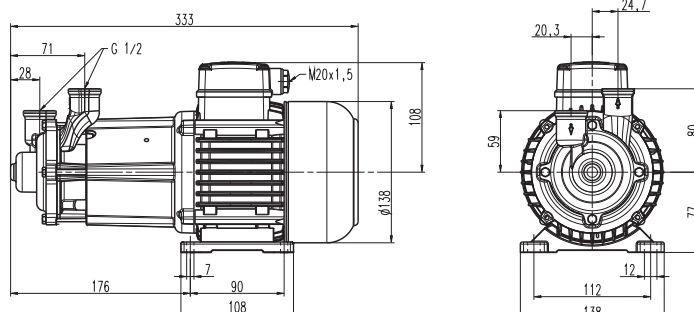

### BMK4

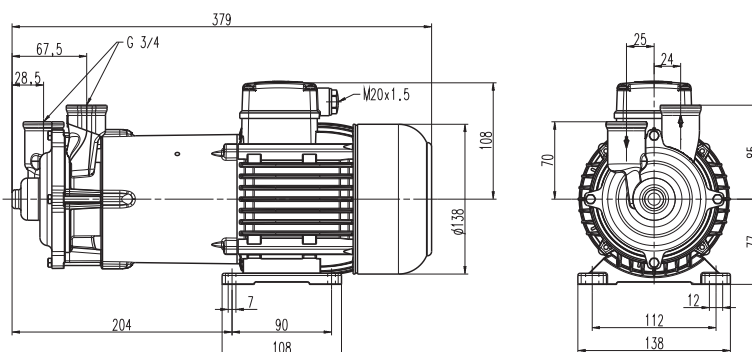

Type	Vol. del. at manom. del. head l/min / m	h mm	Weight kg	Power kW	Voltage 3 ~ V	Fre- quency Hz	Rated current A	Speed 1/min
<b>BMK3</b>	10/35	71	9	0.52	220-240 380-420 460	50 50 60	2.30 1.34 1.34	2750 2750 3400
<b>BMK4</b>	10/48	68	11.5	0.92	220-240 380-420 460	50 50 60	4.7 2.7 2.7	2700 2700 3300

### Miniature Centrifugal Pumps

of the **BMK series** have been designed for **clean water circuits** of up to 160 degree C fluid temperature and up to **7 bar** of system pressure.

The pumps are equipped with a magnetic coupling. The pumps can be mounted vertically or horizontally. The specific design allows the pumps to operate wear poor.

### Applications

Types of fluid  
water up to 160° C at 7 bar system-pressure

### Construction

Pump body	CrNi-steel
Cover	CrNi-steel
Impeller	CrNi-steel
Shaft	Ceramic
Gasket	Split-case

Noise level	
BMK3	65 dBA
BMK4	67 dBA

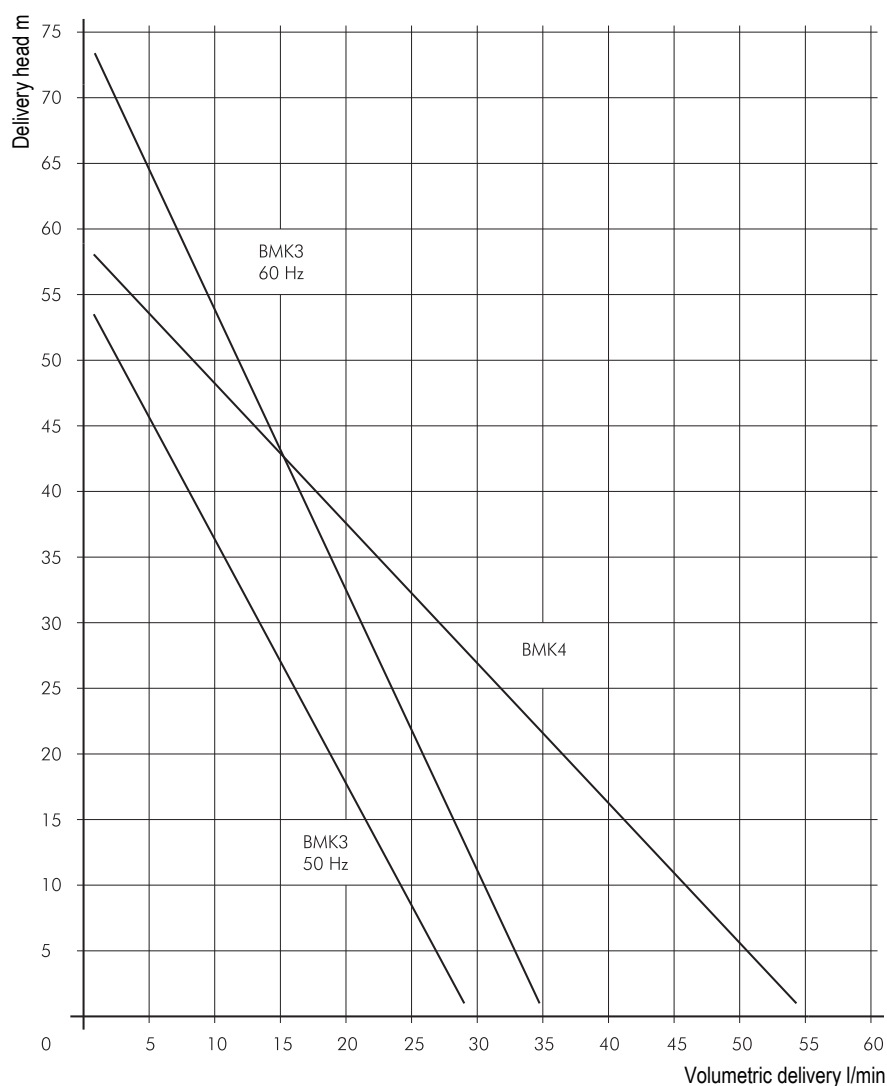

# High Pressure Immersion Pumps

## BFS1 ... TFS6145

### Screw spindles

**Screw spindle pumps** with their **silicon carbide housing** and highly wear resistant spindles are capable of achieving extremely **high pressures**.

Brinkmann **high pressure screw pumps** are designed for pumping filtered and lubricating fluids such as coolant oils and water soluble coolants. High pressure screw spindle pumps are not designed for dry-running.

Screw spindle pumps are positive displacement pumps which always require the installation of a pressure relief valve in order to prevent bursting.

For more information, please refer to the „Application guide lines“.

**The following diagrams reflect an overview of our high pressure screw spindle pump line.**

**For more information, please request our separate “Screw Spindle Pumps” catalogue or visit our website at [www.brinkmannpumps.com](http://www.brinkmannpumps.com)**

#### Applications

- Types of fluid
    - Oils
    - Cooling / cutting oils
    - Coolants
  - Kinematic viscosity
    - 1...90 mm<sup>2</sup>/s (90cSt)
    - over 90 mm<sup>2</sup>/s on request
  - Pumping temperature
    - ...+ 80 °C
  - Recommended filtration levels:
    - Turning, drilling, milling 50 µm
    - Grinding and machining of aluminum (CBN etc.) 20 µm
- For further information please see page 10 in the separate Screw Spindle Pumps catalogue

#### Construction

- |                              |   |
|------------------------------|---|
| Pressure and suction housing | Cast iron, Silicone carbide, highly wear resistance and precision machined          |
| Screw spindles               | Hardened tool steel, specially treated, highly wear resistance and precision ground |
| Seal                         | Viton   |



#### Screw Spindle Pumps BFS1, FFS1, BFS2, FFS2

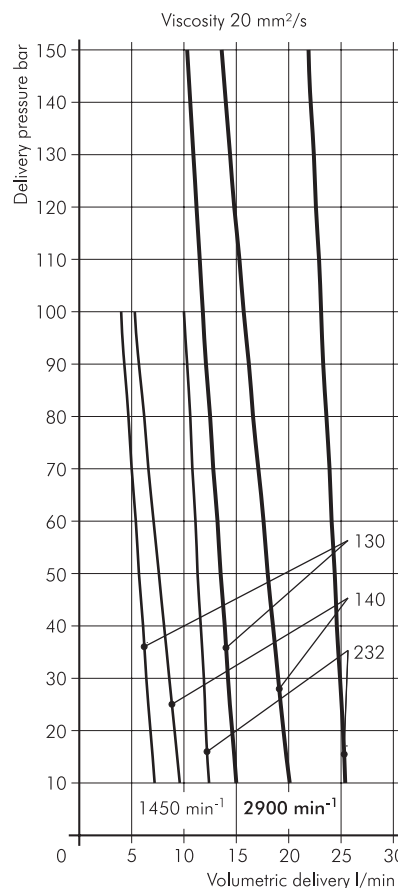
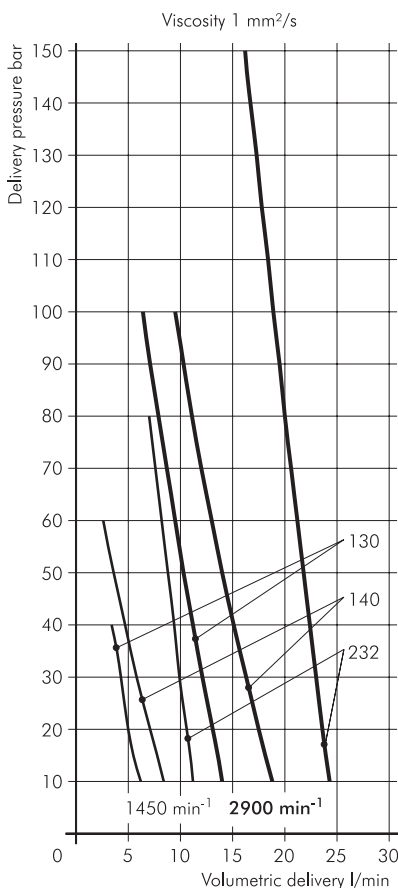

**50 Hz**



# High Pressure Immersion Pumps

## BFS1 ... TFS6145

### Screw spindles

#### Screw Spindle Pumps BFS2, FFS2

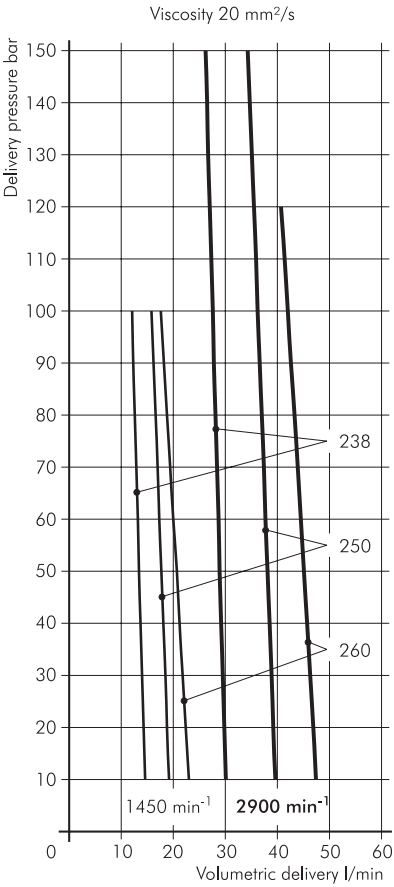
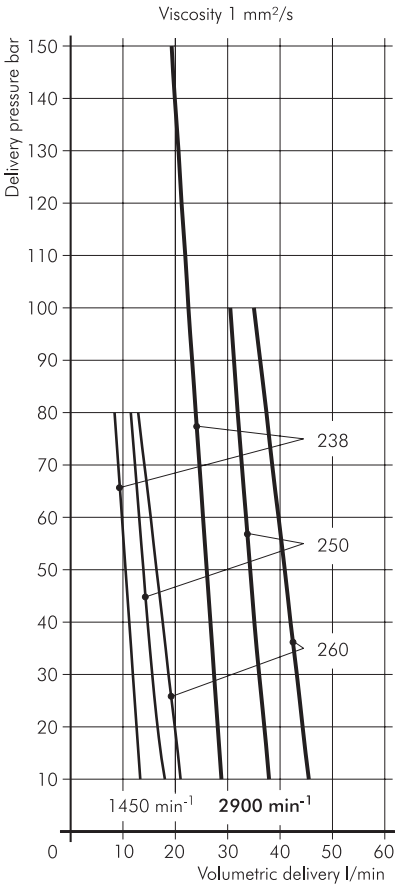

50 Hz

#### Screw Spindle Pumps TFS3, FFS3

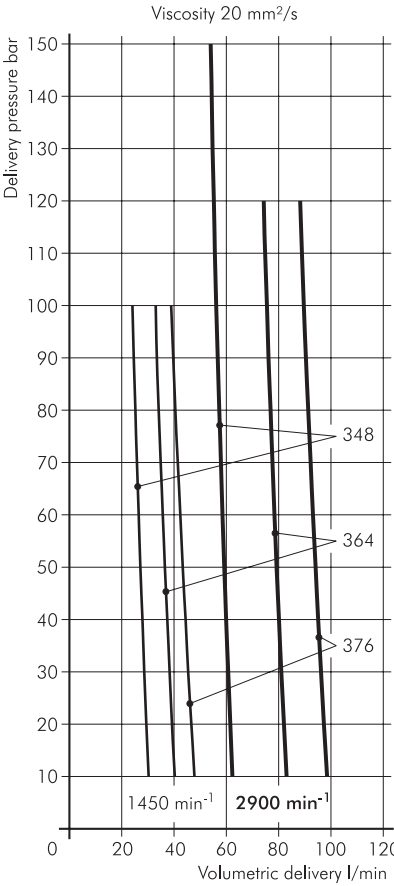
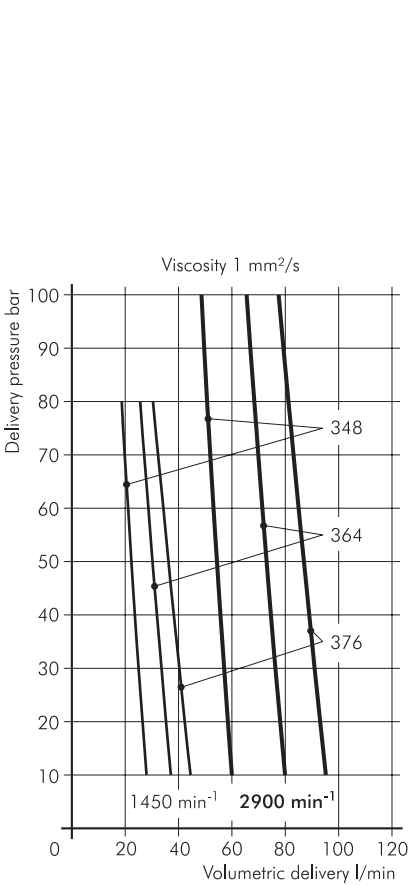

50 Hz



# High Pressure Immersion Pumps

## BFS1 ... TFS6145

### Screw spindles

#### High Pressure Immersion Pumps TFS4, FFS4

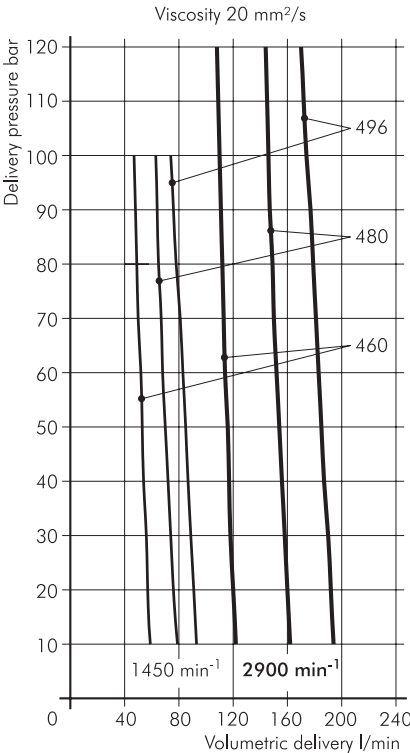
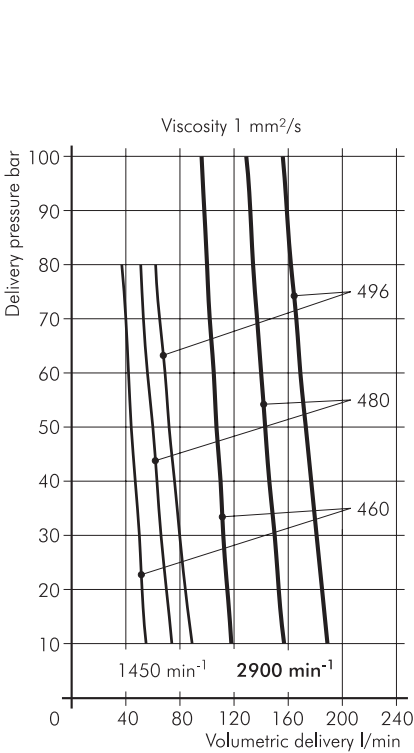

**50 Hz**

#### High Pressure Immersion Pumps TFS5, FFS5

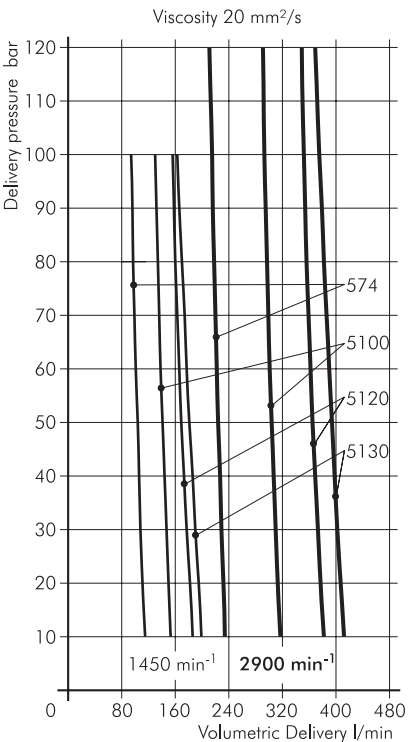
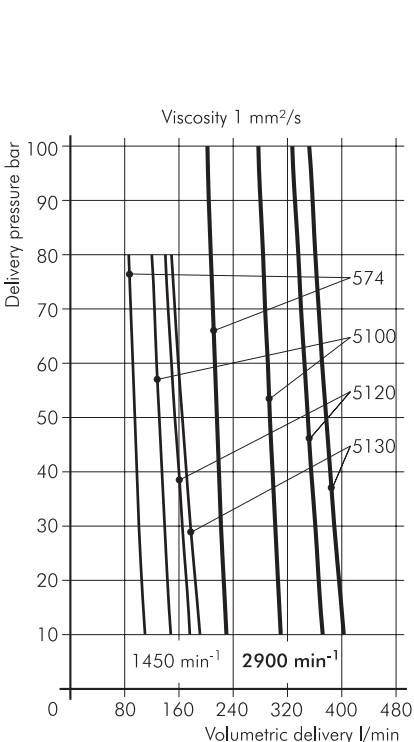

**50 Hz**



# High Pressure Immersion Pumps

## BFS1 ... TFS6145

### Screw spindles

#### Screw Spindle Pumps TFS6, FFS6

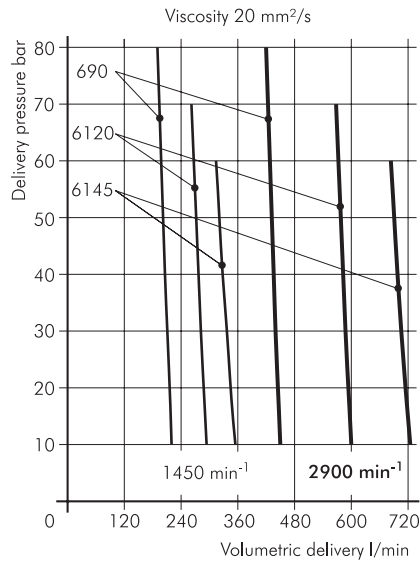
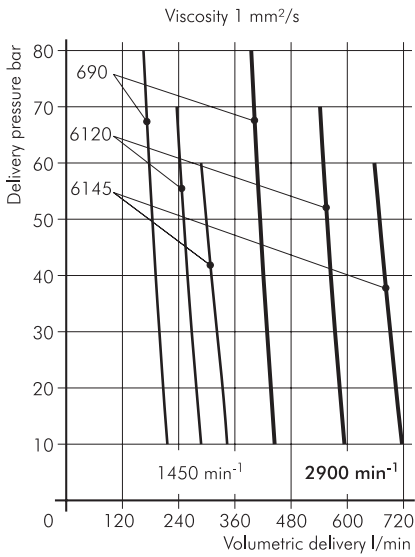

**50 Hz**







# Questionnaire

**Fax** +49(0)2392 / 5006 - 180  
**E-Mail** sales@brinkmannpumps.de

Company ..... Date .....  
Location .....  
Contact partner .....  
Telephone .....

## Pump

Application .....  
.....

Requirement per year (each) .....

### Pumping data

Flow rate l/min. .... Immersion depth .....  
Pressure bar .....  
Delivery head m .....

### Dimensions

### Medium to be pumped

Type .....  
Temperature °C .....  
Viscosity mm<sup>2</sup>/s, cSt .....  
at pumping temperature .....  
Density kg/l .....  
Percentage of solids g/l .....  
Size of solids mm/mm .....  
pH value .....  
Percentage of air in medium .....

### Pump materials

Pump body .....  
Cover .....  
Impeller .....  
Shaft .....  
Seals .....

## Drive

laid out for line power  
 3 x 400 V, 50 Hz       3 x 440 V, 60 Hz       3 x 208-230 V, 60 Hz  
 3 x 415 V, 50 Hz       3 x 460 V, 60 Hz       3 x 200-220 V, 60 Hz  
 3 x 380 V, 50 Hz       3 x 480 V, 60 Hz       1 x 115 V, 60 Hz  
 3 x 200 V, 50 Hz       3 x 380 V, 60 Hz      other .....  
 1 x 230 V, 50 Hz       3 x 400 V, 60 Hz .....

## Motor

Protective system IP55 .....  
Insulation class F .....  
Ambient temperature °C .....  
Frequency control Hz from ..... to .....  
Switch-on operations per min .....  
Motor connection plug HAN  yes  
Motor efficiency class  IE2     IE3

## Other

.....  
.....



Dotted lines for note-taking



The combination of state of the art production equipment, along with lean manufacturing processes and a highly skilled and motivated workforce allows for the highest flexibility and availability of parts at the manufacturing site in Werdohl, Germany. The US subsidiary located in Wixom, Michigan was founded in 1997 and the Japanese subsidiary in Kanagawa near Tokyo opened its doors in 2008.



## *Production*

It has always been a core philosophy of BRINKMANN PUMPS to be able to provide the highest level of service worldwide. In order to achieve this goal, all BRINKMANN PUMPS employees globally go through rigorous training programs focusing on various areas, such as, pump applications, proper selection, consulting, service and repair.



# Quality



At BRINKMANN PUMPS quality begins already with the careful selection of suppliers and materials. All productions processes are continuously monitored. Some key processes and parts are even inspected and controlled on a 100% basis. Shipping and Receiving along

with all internal logistics are also crucial components of Brinkmann Pumps' quality efforts. The entire organization is ISO 9001 certified. Highly skilled employees, most modern measuring equipment, sophisticated testing procedures, and continuous improvements

efforts throughout each step of the production process are all critical components of Quality made by BRINKMANN.

Visit us and convince yourself of our capabilities. Welcome to BRINKMANN PUMPS.

60 JAHRE  
1950 - 2010



**This is the way to find us.**

## **BRINKMANN PUMPS**

**K. H. Brinkmann GmbH & Co. KG**  
Friedrichstraße 2  
58791 Werdohl  
Germany

**Brinkmann Pumps Inc.**  
47060 Cartier Drive  
Wixom, MI 48393  
United States

**Brinkmann Pumps Japan Co. Ltd.**  
1-5-55, Nishishindo, Hiratsuka  
Kanagawa, 254-0019  
Japan

Tel. +49 2392 5006-0  
Fax +49 2392 5006-180  
sales@brinkmannpumps.de  
www.brinkmannpumps.de

Phone +1 248 926 9400  
Fax +1 248 926 9405  
sales@brinkmannpumps.com  
www.brinkmannpumps.com

Phone +81 463 268391  
Fax +81 463 268393  
sales@brinkmannpumps.jp  
www.brinkmannpumps.jp